





# INDICE

## \_INDEX

<b>azienda</b> _company	<b>4</b>
<b>SD interruttori di manovra sezionatori</b> _switch disconnectors	<b>I-1</b>
<b>centralina TMC</b> _changeover control unit tm	<b>I</b>
<b>ST sezionatori retroportella</b> _ door mounting switche	<b>II</b>
<b>VCP interruttori di manovra sezionatori</b> _switch disconnectors	<b>III</b>
<b>VCF interruttori di manovra sezionatori con portafusibili</b> _switch disconnectors fuse	<b>IV</b>
<b>TECHNOSOLAR interruttori di manovra sezionatori</b> _switch disconnectors	<b>V</b>
<b>GT interruttori, sezionatori modulari con e senza portafusibili</b> _switch disconnectors modular with and without fuse	<b>VI</b>
<b>CMA commutatori manuali</b> _manual change-over switches	<b>VII</b>
<b>CMO commutatori motorizzati</b> _motorized change-over switches	<b>VIII</b>

Technoelectric s.r.l.

Via E. Mattei 2/4,  
26823 Castiglione d'Adda LO

[www.technoelectric.it](http://www.technoelectric.it)

Tel: + 39 0377 42581

E-mail: [info@technoelectric.it](mailto:info@technoelectric.it)

# LA STORIA DELL'AZIENDA

## Una storia d'amore per l'Elettromeccanica lunga 40 anni...

**Nel 1981, Ezio Anelli**, brillante imprenditore nel mondo del tessile, con uno spiccato senso degli affari, decide di cambiare settore, e di affacciarsi al mondo dell'Elettromeccanica. Il mondo del tessile, in quegli anni, stava imboccando la via del tramonto, a causa anche di una fortissima delocalizzazione.

**Nasce così Technoelectric**, che inizia la sua storia in un piccolissimo capannone nel paese di Camairago (LO).

Fin dalle sue origini, **si specializza nella produzione di sezionatori BT**, con la consapevolezza di poter guadagnare il suo spazio in quella nicchia di mercato dell'elettromeccanica sensibile ai prodotti di alta qualità.

Il giro d'affari, in crescita esponenziale, costringe l'azienda a spostarsi in una sede più grande, a Castiglione D'Adda, dopo solo 1 anno.



**È il 1982. Il Maggiore dei due figli di Ezio, Matteo, inizia a lavorare in azienda.**

I prodotti iniziano da subito a farsi conoscere per la robustezza e la qualità produttiva.

**Nel 1983 Technoelectric chiude un accordo con la**

**C.G.E.** (Compagnia Generale Elettromeccanica, italianissima azienda che venne poi assorbita dalla General Electric).

La scelta manageriale di una relazione di partnership, con una azienda chiave nel settore è vincente, e produce un ulteriore incremento

della varietà produttiva sospinta anche dal progressivo profilarsi di un orizzonte di mercato sempre più ampio.

Nel 1986, difatti, viene creato un nuovo capannone, poco distante dalla sede precedente, di più di 1.000m<sup>2</sup>.

Con la caduta del muro di Berlino (1989) si apre un infinito mondo di opportunità fuori dai confini Italiani, e le aziende italiane incrementano l'Export.

Technoelectric segue questa tendenza, e cresce, ampliando gli stabilimenti produttivi e creando una rete di rivenditori esteri. È il 1990.

Nel 1993 La costante ricerca della qualità e l'affacciarsi di nuove normative **portano l'azienda ad essere una tra le prime aziende della zona a conformarsi e a certificarsi alla norma UNI EN ISO 9001:2000 per prodotti**, processi e servizi relativi a interruttori di manovra, sezionatori ed unità combinate con fusibili BT.

Nel 1995 **L'Azienda firma un accordo di collaborazione con il gruppo Siemens**. Una partnership che dura ancora oggi.

Per soddisfare le richieste della clientela e per risolvere una serie di problemi in ambito elettromeccanico, l'azienda avverte la necessità di ampliare la propria gamma di prodotti.

**Nel 1996 nascono i sezionatori modulari della linea GT.**



All'affacciarsi del nuovo millennio, la necessità di prodotti sempre più compatti e performanti inizia a farsi sentire.

**Nel 2002 viene difatti lanciata la linea SD, ad oggi la più performante e compatta sul mercato dei sezionatori fino a 160A**, con la creazione, due anni dopo, della loro variante in cassetta (plastica e metallica).

**Nel 2007 Technoelectric decide di ampliare il proprio range di prodotti presentandosi sul mercato della media tensione con un prodotto interamente made in Italy.**

**Il 2010** produce un ulteriore incremento della varietà produttiva, sospinta anche dal progressivo profilarsi di un orizzonte di mercato sempre più ampio: **Nasce la linea per il fotovoltaico, Techno Solar.**

Il triennio 2011-2013 rappresenta la nascita e il perfezionamento dei commutatori manuali della linea SD, dalla taglia 1 fino alla 3.

**Technoelectric è inoltre riuscita a raggiungere un obiettivo ambizioso: integrare sapientemente le linee di prodotto standard con la possibilità di produrre pezzi speciali a seconda delle richieste della clientela.** Ciò ha fatto nascere collaborazioni dirette con dipartimenti della difesa e aziende di distribuzione elettrica in svariati paesi nel mondo.

Gli ultimi anni sono stati caratterizzati dalla nascita di altre partnership importanti, dall'aggiornamento dei prodotti e da una

serrata ricerca e sviluppo, il tutto senza delocalizzare, mantenendo l'indissolubile **legame dell'azienda con il territorio, e con il MADE IN ITALY.**

Per far fronte alla continua e rapida evoluzione dei prodotti e delle richieste dei clienti, l'azienda ha deciso di organizzarsi con una attrezzatura interna, dove si parte dalla progettazione fino alla realizzazione dei propri stampi.

**Oggi, a 40 anni dalla nascita dell'azienda, Technoelectric presenta una gamma rinnovata, con un prodotto nuovo che proietterà l'azienda verso il futuro.**

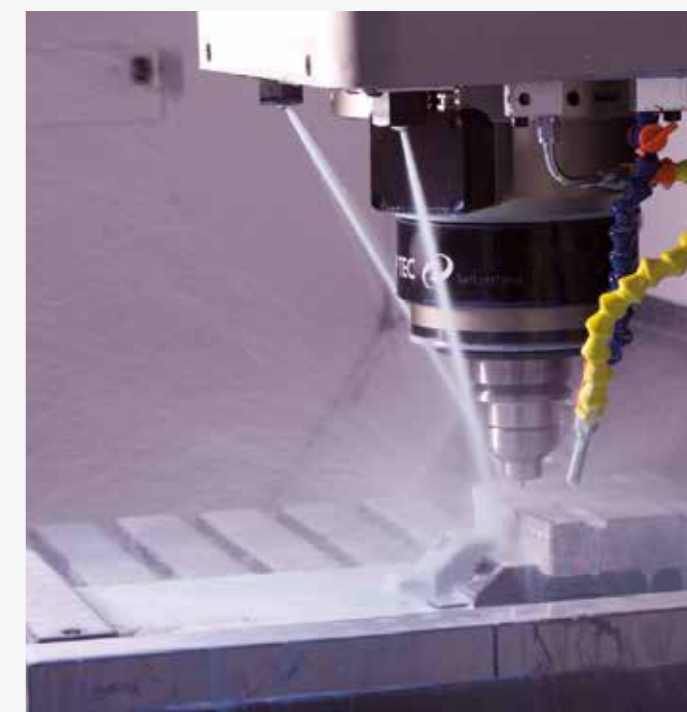



# THE HISTORY OF THE COMPANY

## A 40-year love story for Electromechanics.

**In 1981, Ezio Anelli**, a brilliant entrepreneur in the world of textiles, with a keen sense of business, decided to change sector and enter the world of Electromechanics. The world of textiles, in those years, was taking the path of sunset, also due to a very strong delocalization.

**Technoelectric began its story in a very small warehouse in the town of Camairago (LO).**

Since its origins, it has specialized in the production of LV disconnectors, with the awareness of being able to earn its space in that electromechanical market niche sensitive to high quality products.

The turnover, which was growing exponentially, forces the company to move to a larger location, in Castiglione D'Adda, after only 1 year. It was 1982.

**The eldest of Ezio's two sons, Matteo, started working in the company.**



Matteo Anelli

The products immediately began to make themselves known for their quality and strength.

**In 1983 Ezio Anelli signed an agreement with C.G.E.** (Compagnia Generale Elettromeccanica, an Italian company, absorbed several years after by General Electric).

The managerial choice of a partnership relationship with a key company in the field is a winning one, and created a further increase in production variety, also driven by the progressive growth of foreign markets.

In fact, in 1986 a new 1,000m<sup>2</sup> warehouse was created, not far from the previous site.

With the fall of the Berlin Wall (1989), an infinite world of opportunities opened up outside the Italian borders, and Italian companies increased exports turnover.

Technoelectric followed this trend, and grown, expanding production plants and creating a network of distributors around the globe. It is 1990.

**In 1993, the constant search for quality and the emergence of new regulations led the company to be one of the first companies in the area to comply and certify the UNI EN ISO 9001: 2000 standard for products**, processes and services relating to circuit breakers, switch, disconnectors and units combined with LV fuses.

The following year, the evolution of the Italian market leads to the creation of a network of agents, which allows the company to follow up and process all requests from all over Italy.

Technoelectric signed, **in 1995, collaboration agreement with the Siemens group.** A partnership that continues today.

To met customer demands and to solve a series of problems in the electromechanical field, the company felt the need to expand its range of products.



**In 1996 the modular disconnectors of the GT line were born.**

As the new millennium approaches, the need for increasingly compact and high-performance products began to make itself felt.

**In 2002 the SD line was launched, to date the most performing and compact on the market for disconnectors up to 160A**, with the creation, two years later, of their variant in enclosures (plastic and metal).

**In 2007 Technoelectric decided to expand its range of products by introducing itself to the medium voltage market with a product entirely made in Italy.**

2010 produced a further increase in production variety, also driven by the gradual emergence of an ever wider market horizon: **Techno Solar, the photovoltaic line, was born.**

The three-year period 2011-2013 represents the birth and improvement of the SD line Changeover switches.

**Technoelectric has also managed to achieve an ambitious goal: to wisely integrate the standard product lines with the possibility of producing special pieces according to customer requests.** This had led to direct collaborations with defense departments and electrical distribution companies in various countries around the world.

The last few years have been characterized by: the birth of other important partnerships, updating of products and a deep research and development.

This results has been all made without relocating, maintaining **the company's indissoluble bond with the territory, and with the MADE IN ITALY philosophy.**

To cope with the continuous and rapid evolution of products and customer requests, the company had decided to organize itself with an internal tool shop, where it starts from the design to the realization of its molds.

**Today, for the 40th anniversary of the company, Technoelectric presents a renewed range and a new product, that will project the company into the future.**

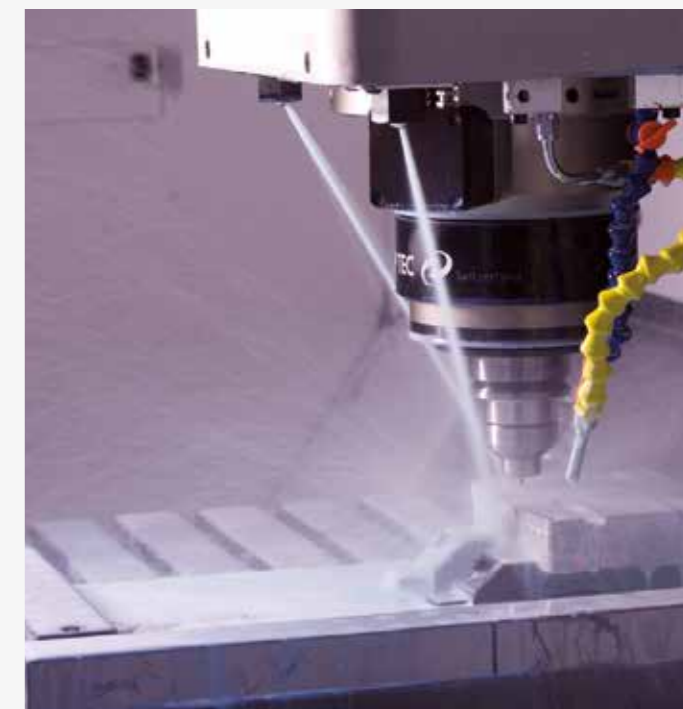





# CERTIFICATI E OMOLOGAZIONI

\_CERTIFICATES AND APPROVALS



Member of CISQ Federation





## INTERRUTTORI DI MANOVRA SEZIONATORI

\_ SWITCHES DISCONNECTORS

SD 16 ÷ 200 A



## COMMUTATORI MANUALI

\_ MANUAL CHANGE OVER  
SWITCHES

CO-SD 16 ÷ 160 A





## SERIE\_SERIES SD

### GENERALITÀ

Gli interruttori-sezionatori modulari della serie SD, consentono l'interruzione e il sezionamento sotto carico di macchine e linee di bassa tensione con correnti nominali da 16 a 200 A.

### IMPIEGO

Gli apparecchi della serie SD sono abitualmente impiegati nelle seguenti funzioni:

- interruttore generale
- interruttore per partenze motori
- interruttore di sicurezza
- sezionatore

### CARATTERISTICHE GENERALI

Alto potere d'interruzione (AC 22 A - AC 23 A)  
 Doppia interruzione per ogni polo  
 Elevata durata meccanica ed elettrica  
 Adatto per l'utilizzo in climi tropicali  
 Grado di protezione IP20 (accessori inclusi)  
 Esecuzione modulare montaggio su profilato DIN 35 mm e a vite, finestra modulare 45 mm.

### GAMMA

SD1 corpo tripolare con le portate da 16 - 25 - 32 - 40 - 63 A  
 SD2 corpo tripolare con le portate da 63 - 80 - 100 - 125 A  
 SD3 corpo tripolare con le portate da 100 - 125 - 160 - 200 A

### POLI AGGIUNTIVI

Quarto polo neutro standard con contatti ad apertura posticipata e chiusura anticipata rispetto ai contatti di fase.  
 Quarto polo neutro passante.  
 Polo di terra passante. Polo contemporaneo a richiesta.

### COMANDO

Maniglia diretta nera (esecuzione standard), o di emergenza lucchettabile in posizione di zero.  
 Maniglia con blocco porta, nera, o di emergenza, con possibilità di tre blocchi lucchettabili in posizione di 0.  
 Grado di protezione IP 65.

### CONDIZIONI NORMALI DI SERVIZIO, MONTAGGIO E TRASPORTO

temperatura ambiente di immagazzinamento e trasporto - 25°C + 55°C  
 temperatura ambiente di funzionamento - 20°C + 40°C  
 in caso di temperatura ambiente (t<sub>a</sub>) superiore, applicare la seguente formula di declassamento:

$$I_{The} = k I_{Tn} \text{ dove } K = 1 - \frac{t - 40}{100}$$

altitudine max 2000 m s.l.m.  
 grado di inquinamento 3 secondo IEC 60947-1  
 tipo di servizio (secondo UNI EN 60947-1):  
 8 ore; ininterrotto; intermittente 60% classe 30  
 Per condizioni di impiego diverse consultare il costruttore.

### CONFORMITÀ ALLE NORME

IEC 60947-1 | IEC 60947-3 | UNI EN 60947-1 | UNI EN 60947-3 | UL 508A

### CERTIFICATI E OMOLOGAZIONI

EAC, CSA

### GENERALITIES

The modular switch disconnectors of SD series, allow the breaking and the disconnecting on load of equipment on low voltage at nominal current from 16 to 200 A.

### USE

The switch disconnectors of SD series are commonly used for the following purposes:  
 main switch  
 switch for motors  
 safety switch  
 disconnecter

### GENERAL CHARACTERISTICS

High breaking capacity (AC 22 A - AC 23 A)  
 Double break contacts on each pole  
 High electrical and mechanical endurance  
 Resistant to damp heat  
 IP20 degree of protection (with accessory)  
 Modular execution, basic mounting on 35 mm DIN rail and by screws, modular window 45 mm.

### RANGE

SD1 three poles 16 - 25 - 32 - 40 - 63 A  
 SD2 three poles 63 - 80 - 100 - 125 A  
 SD3 three poles 100 - 125 - 160 - 200 A

### ADDITIONAL POLES

Fourth neutral pole makes earlier and opens later than the phase contacts.  
 Fourth pole solid neutral.  
 Earth pole. Contemporary pole under request.

### OPERATING MECHANISM

Black (standard execution) or emergency direct handle padlockable in 0 position. Handle with door interlock handle, black or emergency handle padlockable with up to three padlocks in 0 position.  
 IP 65 degree of protection.

### STANDARD SERVICE, MOUNTING AND TRANSPORT CONDITIONS

Transport and storage ambient temperature - 25°C + 55°C  
 working ambient temperature - 20°C + 40°C  
 in case of higher ambient temperature (t<sub>a</sub>), consider the following derating formula:

$$I_{The} = k I_{Tn} \text{ where } K = 1 - \frac{t - 40}{100}$$

altitude max 2000 m a.s.l.  
 pollution degree 3 according IEC 60947-1 duty (UNI EN 60947-1):  
 8 hours; uninterrupted; intermittent 60% class 30  
 For other operating conditions please contact the manufacturer.

### CONFORMITY TO STANDARDS

IEC 60947-1 | IEC 60947-3 | UNI EN 60947-1 | UNI EN 60947-3 | UL 508A

### CERTIFICATES AND APPROVALS

EAC, CSA



Tipo Type	Corrente nominale Rated current	IEC				UL			
		Maniglia diretta Direct handle		Maniglia emergenza Direct emergency handle		Maniglia diretta Direct handle		Maniglia emergenza Direct emergency handle	
A	POLI _POLES	CODICE _CODES	POLI _POLES	CODICE _CODES	POLI _POLES	CODICE _CODES	POLI _POLES	CODICE _CODES	
SD1	16	3	19300	3	19310	3	19300UL	3	19310UL
		4	19330	4	19350	4	19330UL	4	19350UL
		6	193006	6	193106	6	193006UL	6	-
		8	193308	8	193508	8	-	8	-
	25	3	19301	3	19311	3	19301UL	3	19311UL
		4	19331	4	19351	4	19331UL	4	19351UL
		6	193016	6	193116	6	193016UL	6	-
		8	193318	8	193518	8	-	8	-
	32	3	19302	3	19312	3	19302UL	3	19312UL
		4	19332	4	19352	4	19332UL	4	19352UL
		6	193026	6	193126	6	193026UL	6	-
		8	193328	8	193528	8	-	8	-
	40	3	19303	3	19313	3	19303UL	3	19313UL
		4	19333	4	19353	4	19333UL	4	19353UL
		6	193036	6	193136	6	193036UL	6	-
		8	193338	8	193538	8	-	8	-
63	3	19304	3	19314	3	-	3	-	
	4	19334	4	19354	4	-	4	-	
	6	193046	6	193146	6	-	6	-	
	8	193348	8	193548	8	-	8	-	
SD2	63	3	-	3	-	3	19205UL	3	19215UL
		4	-	4	-	4	19235UL	4	19255UL
		6	-	6	-	6	192056UL	6	-
		8	-	8	-	8	-	8	-
	80	3	19206	3	19216	3	19206UL	3	19216UL
		4	19236	4	19256	4	19236UL	4	19256UL
		6	192066	6	192166	6	192066UL	6	-
		8	192368	8	192568	8	-	8	-
100	3	19207	3	19217	3	19207UL	3	19217UL	
	4	19237	4	19257	4	19237UL	4	19257UL	
	6	192076	6	192176	6	192076UL	6	-	
	8	192378	8	192578	8	-	8	-	
125	3	19208	3	19218	3	19208UL	3	19218UL	
	4	19238	4	19258	4	19238UL	4	19258UL	
	6	192086	6	192186	6	192086UL	6	-	
	8	192388	8	192588	8	-	8	-	
SD3	100	3	-	3	-	3	19700UL	3	19710UL
		4	-	4	-	4	19730UL	4	19750UL
		6	-	6	-	6	-	6	-
		8	-	8	-	8	-	8	-
	125	3	19701	3	19711	3	19701UL	3	19711UL
		4	19731	4	19751	4	19731UL	4	19751UL
		6	197016	6	197116	6	-	6	-
		8	197318	8	197518	8	-	8	-
160	3	19702	3	19712	3	19702UL	3	19712UL	
	4	19732	4	19752	4	19732UL	4	19752UL	
	6	197026	6	197126	6	-	6	-	
	8	197328	8	197528	8	-	8	-	
200	3	19703	3	19713	3	-	3	-	
	4	19733	4	19753	4	-	4	-	
	6	197036	6	197136	6	-	6	-	
	8	197338	8	197538	8	-	8	-	

**SERIE\_SERIES SD**

Caratteristiche tecniche _technical features	Tipo _Type	SD1					SD2					SD3		
		In	A	16	25	32	40	63	80	100	125	125	160	200
Tensione nominale d' isolamento _Rated insulation voltage	Ui	V	1500	1500	1500	1500	1500	1500	1500	1500	1500	1500	1500	
Tensione nominale tenuta impulso _Shock resistance	Uimp	kV	4	4	4	4	4	8	8	8	8	8	8	
Corrente nominale termica a 40°C _Thermal current at 40°C	Ith/ Ithe	A	16	25	32	40	63	80	100	125	125	160	200	
Corrente nominale d' impiego _Rated operational current														
AC-21A	415V	A	16	25	32	40	63	80	100	125	125	160	200	
	500V	A	16	25	32	40	63	80	100	125	125	160	160	
	690V	A	16	25	32	40	63	80	100	125	125	160	160	
AC-22A	415V	A	16	25	32	40	63	80	100	125	125	160	200	
	500V	A	16	25	32	40	63	80	100	125	125	160	160	
	690V	A	16	25	32	40	63	80	100	125	125	160	160	
AC-23A/B	415V	A	16	25	32	40	63	80	100	100	125	160	160	
	500V	A	16	16/25	32	40	63	63	63	63	125	160	160	
	690V	A	16	16/25	32	40	63	63	63	63	125	125	125	
Potere di chiusura a 415V AC23 _Rated making capacity at 415V AC23		A	160	250	320	400	630	800	1000	1250	1250	1600	1600	
Potere di interruzione a 415V AC23 _Breaking capacity at 415V AC23		A	128	200	256	320	504	640	800	1024	1000	1280	1280	
Potenza nominale di impiego AC23 _Rated operational power AC23	415V	kW	8	11	14	18	29	37	46	46	55	69	69	
	500V	kW	8	14	17	22	35	35	35	35	65	83	83	
	690V	kW	12	19	24	31	48	48	48	48	90	90	90	
Corrente di breve durata per 1 sec _Short-circuit withstand current 1 sec	400V	kA	1,1	1,1	1,1	1,1	1,1	1,5	1,5	1,5	3	3	3	
Potere di chiusura in corto circuito _Short-circuit making capacity	400V	kA	2,1	2,1	2,1	2,1	2,1	3,5	3,5	3,5	4,5	4,5	4,5	
Corrente di corto circuito condizionata da fusibile _fuse protected short-circuit withstand														
Tipo fusibile gG DIN _gG DIN Backup associated fuse rating		A	16	25	32	40	63	80	100	125	125	160	200	
Valore efficace/R.M.S. value		kA	10	10	10	10	10	10	10	10	10	10	10	
Durata meccanica _Mechanical endurance		n.	10000	10000	10000	10000	10000	10000	10000	10000	10000	10000	10000	
Durata elettrica _Electrical endurance		n.	1500	1500	1500	1500	1500	1500	1500	1500	1500	1500	1500	
Potenza dissipata per polo _Power loss per pole		W	0,1	0,1	0,2	0,3	0,8	1,3	2	3,1	2,5	3	3	
Dimensione cavo _Cable section		mmq	16	16	16	16	16	50	50	50	70	70	70	
Max.torsione terminali _Tightening torque		Nm	2	2	2	2	2	2,5	2,5	2,5	6	6	6	
Sforzi di manovra _Operating torque		Nm	1,6	1,6	1,6	1,6	1,6	2	2	2	2,6	2,6	2,6	
Peso netto _Net weight	3P	Kg.	0,13	0,13	0,13	0,13	0,13	0,25	0,25	0,25	0,4	0,4	0,4	
	4P	Kg.	0,16	0,16	0,16	0,16	0,16	0,32	0,32	0,32	0,5	0,5	0,5	
	6P	Kg.	0,3	0,3	0,3	0,3	0,3	0,55	0,55	0,55	0,8	0,8	0,8	
	8P	Kg.	0,4	0,4	0,4	0,4	0,4	0,62	0,62	0,62	1	1	1	



Caratteristiche tecniche _technical features	Tipo _Type	SD1					SD2					SD3		
		In	A	16	25	32	40	63	80	100	125	100	125	160
Corrente nominale _Rated current		A	16	25	32	40	63	80	100	125	125	160	200	
Uso generale _General use		V AC	600	600	600	600	600	600	600	600	600	600	600	
Valore di corto circuito _Short circuit rating		kA	5	5	5	5	5	5	5	5	10	10	10	
Valore fusibile _Fuse rating		A	40	40	40	40	125	125	125	125	175	175	175	
Max potenza impiego_Max horsepower UL 3 fasi_3 phases	120V	Hp	3	3	3	3	5	5	5	5	15	20	20	
	240V	Hp	5	7,5	7,5	10	10	15	15	15	30	40	40	
	415V	Hp	7,5	10	10	15	20	25	25	25	50	60	60	
	480V	Hp	10	15	20	20	25	30	30	30	75	100	100	
	600V	Hp	15	20	25	30	30	40	40	40	100	125	125	
Max potenza impiego_Max horsepower UL 1 fase_1 phase	120V	Hp	3	3	3	3	3	5	5	5	-	-	-	
	240V	Hp	5	5	5	5	8	10	10	10	-	-	-	
	480V	Hp	15	15	15	15	20	20	20	20	-	-	-	
Max carico avviamento motore _Max full load motor running UL 3 fasi_3 phases	120V	A	19,2	19,2	19,2	19,2	30,4	30,4	30,4	30,4	84	108	108	
	240V	A	15,2	22	22	28	42	42	42	42	80	104	104	
	415V	A	14	18	18	27	44	44	44	44	83	103	103	
	480V	A	14	21	27	27	40	40	40	40	84	104	104	
	600V	A	17	22	27	32	41	41	41	41	99	125	125	
Max carico avviamento motore _Max full load motor running UL 1 fase_1 phase	120V	A	34	34	34	34	34	56	56	56	-	-	-	
	240V	A	28	28	28	28	40	50	50	50	-	-	-	
	480V	A	34	34	34	34	44	44	44	44	-	-	-	
Potenza nominale di impiego AC23 _Rated operational power AC23	415V	kW	8	11	14	18	29	37	46	46	55	69	69	
	500V	kW	8	14	17	22	35	35	35	35	65	83	83	
	690V	kW	12	19	24	31	48	48	48	48	90	90	90	
Durata meccanica _Mechanical endurance		n.	6.000	6.000	6.000	6.000	6.000	6.000	6.000	6.000	6.000	6.000		
Durata elettrica _Electrical endurance		n.	6.000	6.000	6.000	6.000	6.000	6.000	6.000	6.000	6.000	6.000		
Dimensione cavi _Cable section		AWG	6+16	6+16	6+16	6+16	1+6	1+6	1+6	1+6	3/0+6	3/0+6	3/0+6	
Tipo terminale _Tightening type			Cu	Cu	Cu	Cu	Cu	Cu	Cu	Cu	Cu	Cu	Cu	
Max.torsione terminali _Tightening torque		Nm	2	2	2	2	3,5	3,5	3,5	3,5	6	6	6	
Peso netto _Net weight		Kg	0,13	0,13	0,13	0,13	0,25	0,25	0,25	0,25	0,25	0,25	0,25	



**SD1 3 - 4 POLI \_poles**

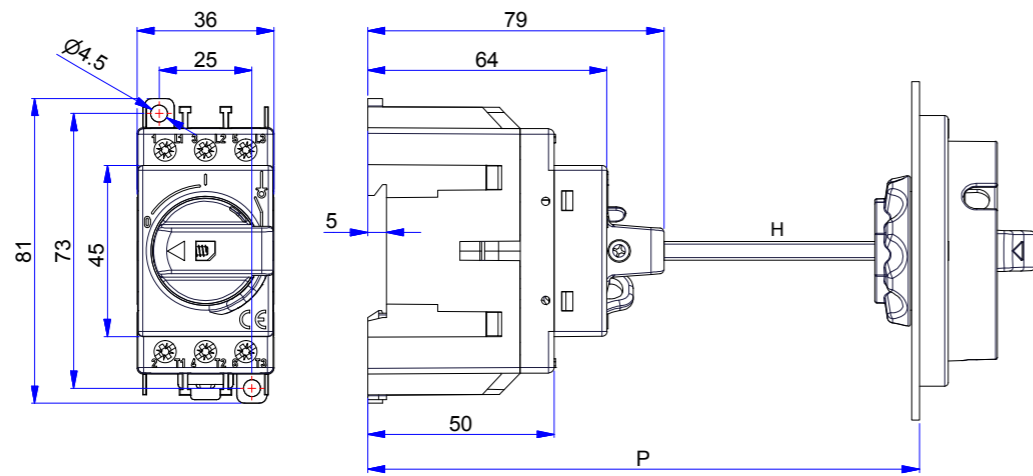

SD1			
HANDLE	P	C	H
19460 - 19461	--	34	P-C
19466 - 19467	--	22	P-C

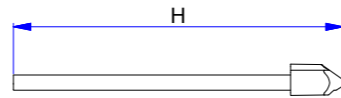

**SD2 3 - 4 POLI \_poles**

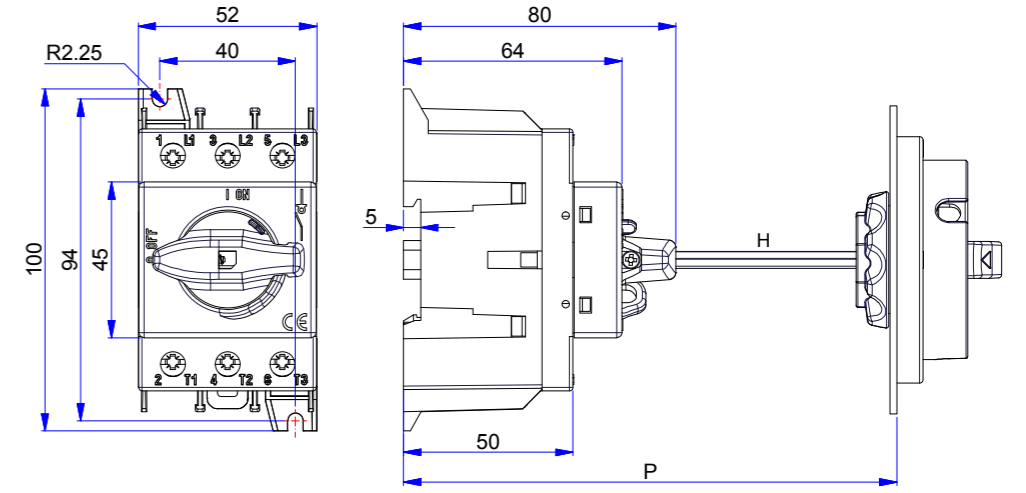

SD2			
HANDLE	P	C	H
19460 - 19461	--	32	P-C
19466 - 19467	--	20	P-C

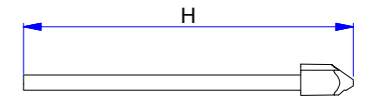

**SD1 6 - 8 POLI \_poles**

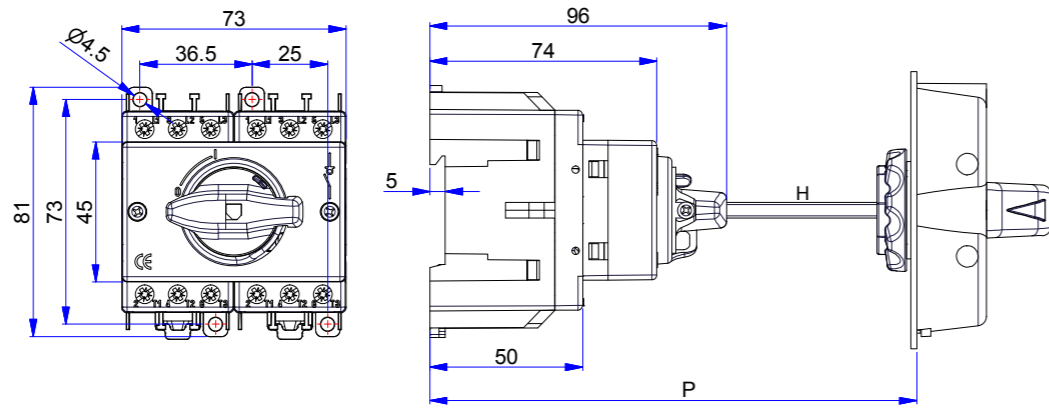

SD1 6 POLI			
HANDLE	P	C	H
19466 - 19467	--	40	P-C

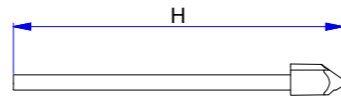

**SD2 6 - 8 POLI \_poles**

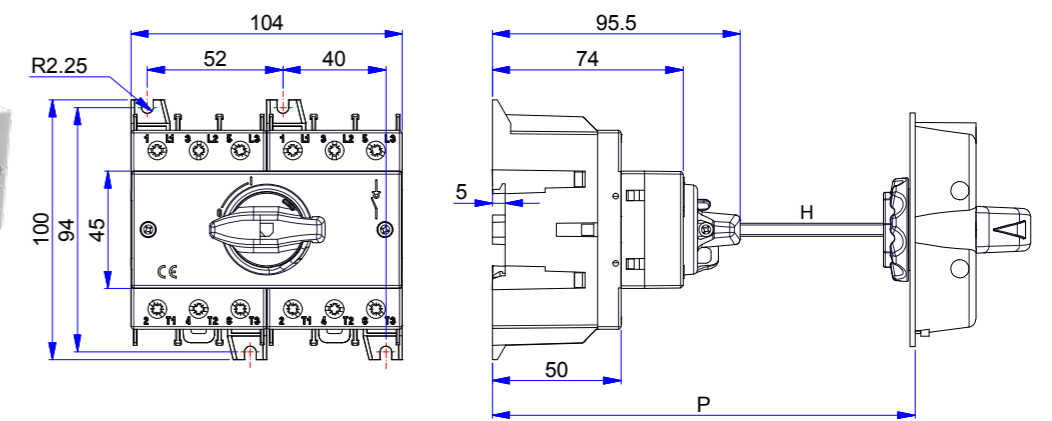

SD2 6 POLI			
HANDLE	P	C	H
19466 - 19467	--	40	P-C

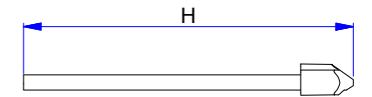

**SD3 3 - 4 POLI \_poles**

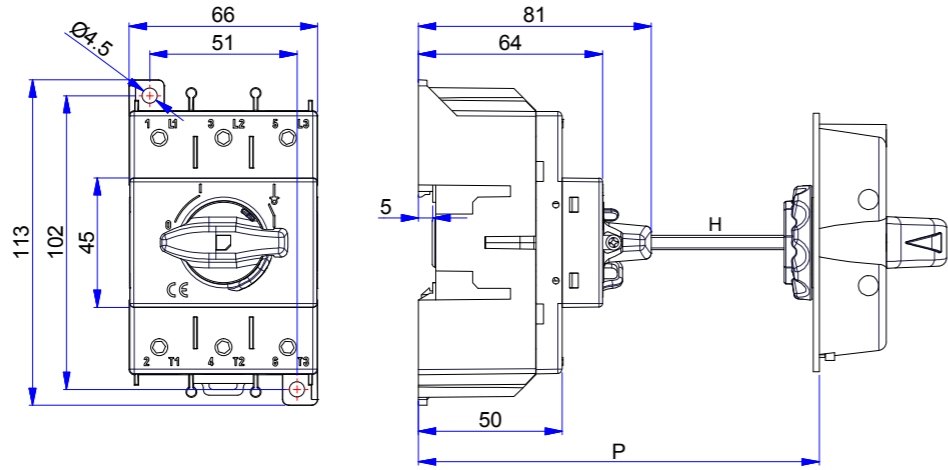

SD3			
HANDLE	P	C	H
19460 - 19461	--	35	P-C
19466 - 19467	--	23	P-C

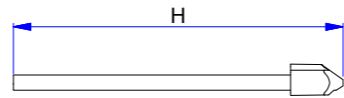

**3-4 POLI \_poles**

**MANIGLIE BLOCCO PORTA \_Door interlock handles**



19461

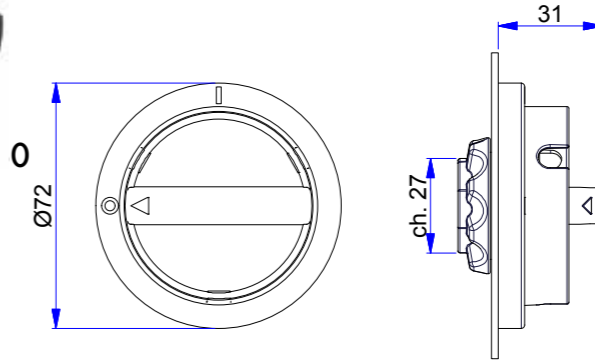

Foratura portella \_Door drilling

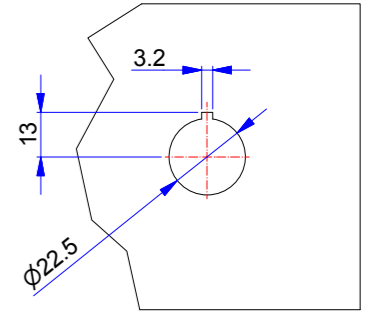

**SD3 6 - 8 POLI \_poles**

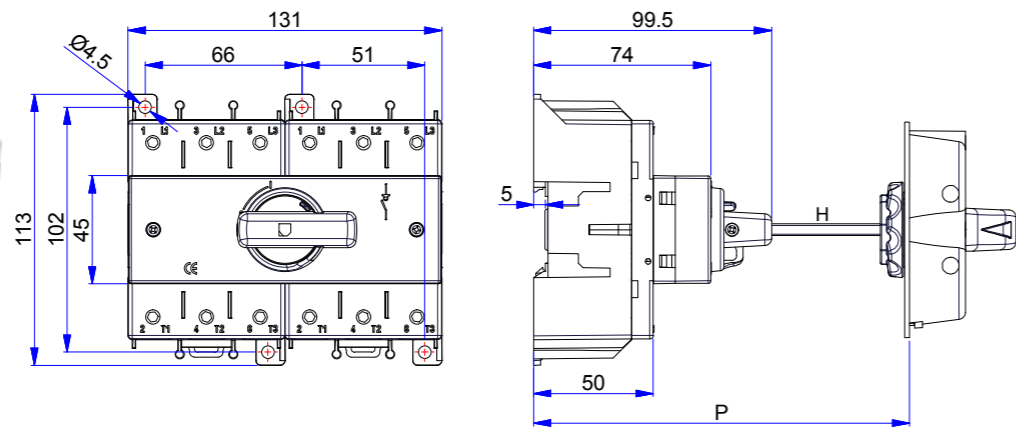
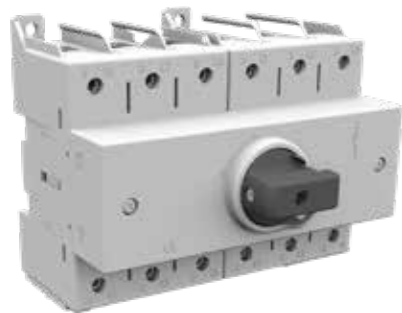

SD3 6 POLI			
HANDLE	P	C	H
19466 - 19467	--	40	P-C

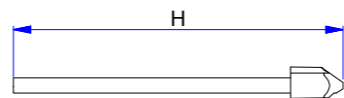

**3-4 POLI / 6-8 POLI \_poles**

**MANIGLIE CON SBLOCCO PORTA \_handles with defeater mechanism**



19466

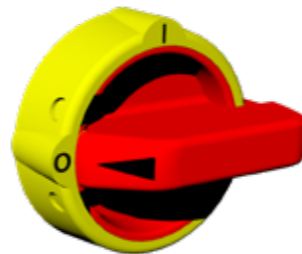

19467

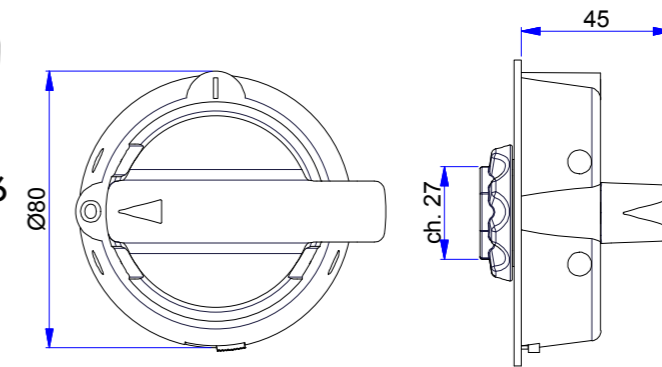

Foratura portella \_Door drilling

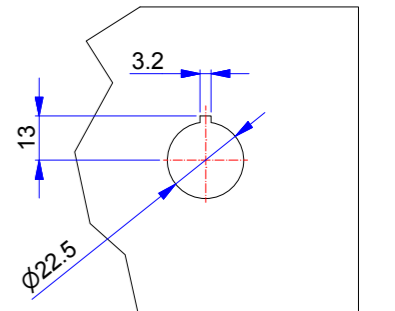

**ALBERI DI COMANDO CON PUNTALE \_shaft for external operation with tip**



Tipo _type	SD1 - SD2 alluminio _aluminium			SD1 - SD2 - SD3 acciaio _steel		
	3-4			3-4   6-8		
Poli _poles						
mm	100	200	300	100	200	300
Codice _code	19535-100P	19535-200P	19535-300P	19534-100P	19534-200P	19534-300P



## SERIE\_SERIES SD

montaggio poli aggiuntivi  
\_additional poles assembly

montaggio contatti ausiliari  
\_auxiliary contacts assembly

montaggio poli aggiuntivi + contatti ausiliari  
\_additional poles + auxiliary contacts assembly

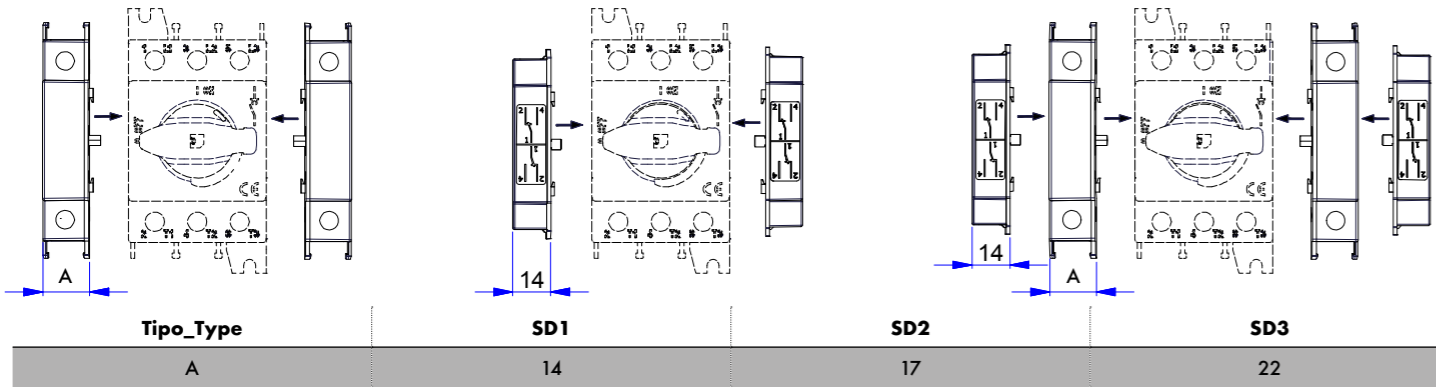

Per il montaggio dei contatti ausiliari addossati al 4° polo, ordinare la confezione viti cod 11190311  
\_For the installation of the auxiliary contacts on the 4th pole, please order the screws set with code 11190311

Contatti ausiliari in scambio  
Apertura anticipata rispetto all'apertura dei contatti principali dell'interruttore  
Portata nominale 16A  
Portata termica 20A

\_Auxiliary contacts break before make contacts switches  
Rated current 16A  
Thermal current 20A

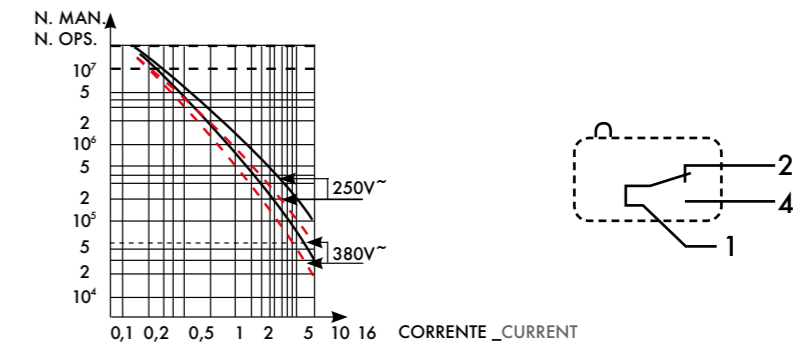

### 4° POLO NEUTRO \_4th pole neutral

### MORSETTO DI TERRA \_Earthing neutral



SD1 19320  
SD2 19418  
SD3 19450



SD1 19322  
SD2 19422  
SD3 19452

### NEUTRO PASSANTE \_Solid neutral

### 4° POLO CONTEMPORANEO \_Contemporary 4th pole



SD1 19321  
SD2 19420  
SD3 19451



SD1 19442  
SD2 19443  
SD3 19444

### CONTATTI AUSILIARI IN SCAMBIO 1NA + 1NC \_auxiliary contacts 1NO + 1NC



Contatti ausiliari in scambio terminali a vite  
\_Auxiliary contacts screw terminals

Tipo_type	SD1	SD2	SD3
Codice_code	19429	19429	19429

Contatti ausiliari in scambio terminali a Faston  
\_Auxiliary contacts Faston terminals

Tipo_type	SD1	SD2	SD3
Codice_code	19430	19430	19430

### KIT COPRI TERMINALI 4° POLO \_4th pole terminals cover kit



SD1 19426  
SD2 19427  
SD3 19454

### KIT COPRI TERMINALI 3 POLI \_3 poles terminals cover kit

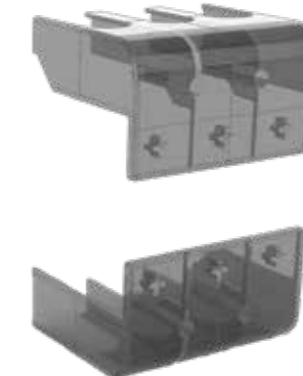

SD1 19424  
SD2 19425  
SD3 19453

### MORSETTO ADATTATORE 200A PER CAVI DA 95MM<sup>2</sup> \_Terminal adapter for 95 mm<sup>2</sup> cables



Il codice include 3 pezzi \_3 pcs in each code

Codice\_code : 19565

Number of pole	Max. Cross section	Nominal current	Nominal voltage
1	120	200 - 190	690

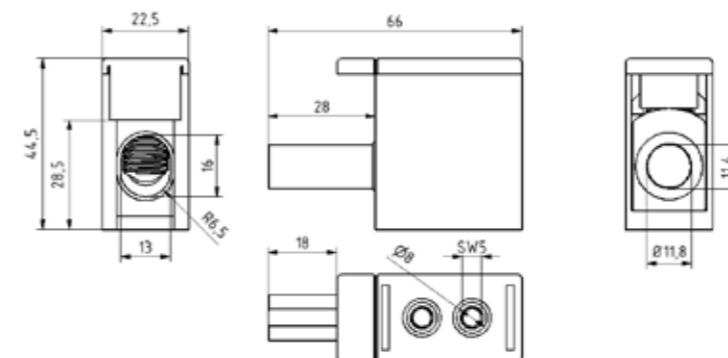

Adattatore terminali per cavo da 95 mmq. per il collegamento di conduttori in alluminio e rame alle apparecchiature. Il corpo è in alluminio stagnato e l'alloggiamento è in poliammide.

\_Terminal Adapter for 95 sqmm cable. for connecting Al-and Cu-conductors to equipment. Body is made of tin-plated aluminium and housing is polyamid.

# COMMUTATORI MANUALI \_MANUAL CHANGEOVER SWITCHES CO-SD 16 ÷ 160 A



## GENERALITÀ COMMUTATORE SD

I commutatori manuali SD, consentono la commutazione di 2 linee elettriche separate di bassa tensione. Sono realizzati interbloccando due normali interruttori della serie SD

Disponibili in versione standard I-0-II (pos 0 entrambi i sezionatori sono aperti) ed in versione "OL" a transizione chiusa I-I+II-II (pos I+II entrambi i sezionatori sono chiusi).

## GAMMA

CO-SD1 commutatore con portate da 16 - 25 - 32 - 40 - 63 A  
CO-SD2 commutatore con portate da 80 - 100 - 125 A  
CO-SD3 commutatore con portate da 125 - 160 A

## COMANDO

Maniglia diretta lucchettabile in posizione di zero. Maniglia con e senza blocco porta.

## CONFORMITÀ ALLE NORME

IEC 60947/1-3 | UNI EN 60947/1-3 | UL | EAC | CSA

## \_SD CHANGE-OVER SWITCHES GENERALITIES

The manual change-over switches SD series, allow the change-over of two low voltage electrical circuits. They are made by two standard switches of SD series mechanically interlocked

Available in standard version I-0-II (pos 0 both switches are OFF) and in close transition "OL" version I-I+II-II (pos I+II both swices are ON).

## \_RANGE

CO-SD1 change-over switches 16 - 25 - 32 - 40 - 63 A  
CO-SD2 change-over switches 80 - 100 - 125 A  
CO-SD3 change-over switches 125 - 160 A

## \_OPERATING MECHANISM

Direct handle padlockable in 0 position. Handle with and without door interlock handle.

## \_CONFORMITY TO STANDARDS

IEC 60947/1-3 | UNI EN 60947/1-3 | UL | EAC | CSA

## CODICI ORDINAZIONE \_ORDER REFERENCES

Tipo _Type	Corrente nominale _Rated current	poli _poles	IEC		UL		
			Versione I-0-II Version I-0-II	Versione I - I+II - II Version I - I+II - II	poli _poles	VERSIONE I-0-II VERSION I-0-II	
CO SD1	16A	3	193003	193003OL	3	193003UL	
		4	193303	193303OL	4	-	
	25A	3	193013	193013OL	3	193013UL	
		4	193313	193313OL	4	-	
	32A	3	193023	193023OL	3	193023UL	
		4	193323	193323OL	4	-	
	40A	3	193033	193033OL	3	193033UL	
		4	193333	193333OL	4	-	
	63A	3	193043	193043OL	3	-	
		4	193343	193343OL	4	-	
	CO SD2	63A	3	-	-	3	192053UL
			4	-	-	4	-
80A		3	192063	192063OL	3	192063UL	
		4	192363	192363OL	4	-	
100A		3	192073	192073OL	3	192073UL	
		4	192373	192373OL	4	-	
125A	3	192083	192083OL	3	192083UL		
	4	192383	192383OL	4	-		
CO SD3	125A	3	197013	197013OL	3	-	
		4	197313	197313OL	4	-	
	160A	3	197023	197023OL	3	-	
		4	197323	197323OL	4	-	



Dettaglio versione  
Overlapping (OL)  
\_Close look to Over-  
lapping (OL) version



Dettaglio versione  
Commutatore (CO)  
\_Close look to Chan-  
geover (CO) version

**CO SD1**

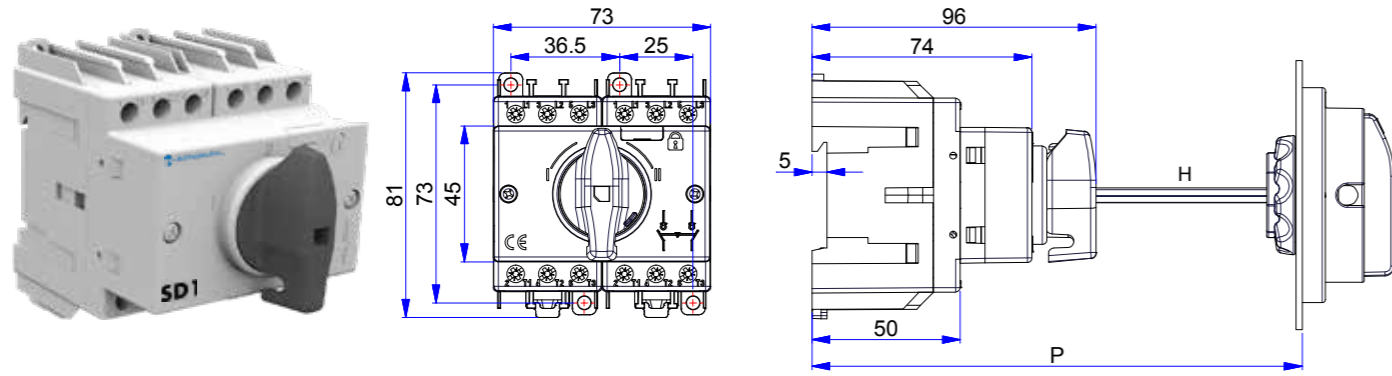

CO SD1				
HANDLE	P	C	H	
19462	--	52	P-C	
19459	--	40	P-C	

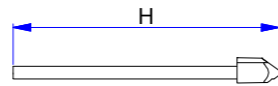

**CO SD1 OL**

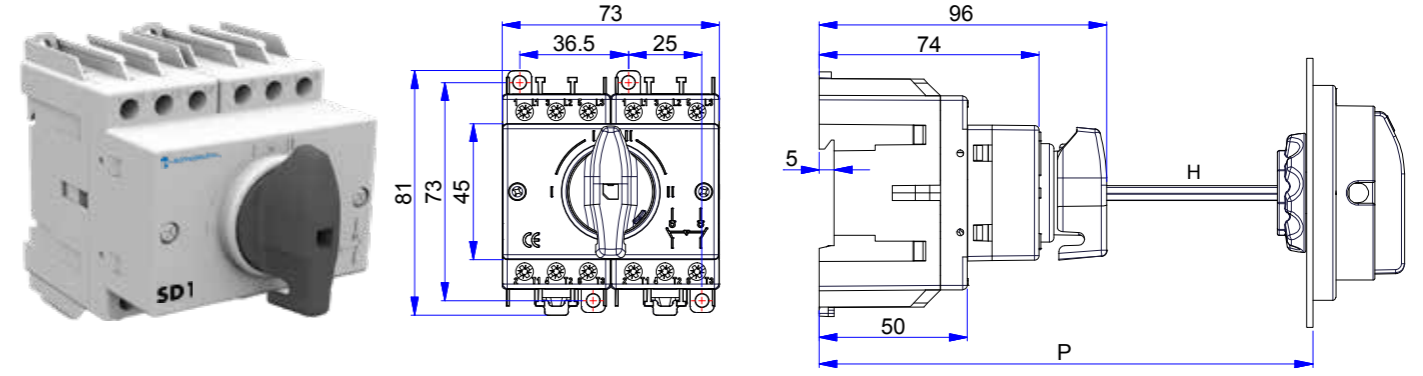

CO SD1 OL				
HANDLE	P	C	H	
19457	--	52	P-C	
19458	--	40	P-C	

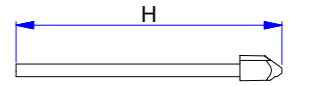

**CO SD2**

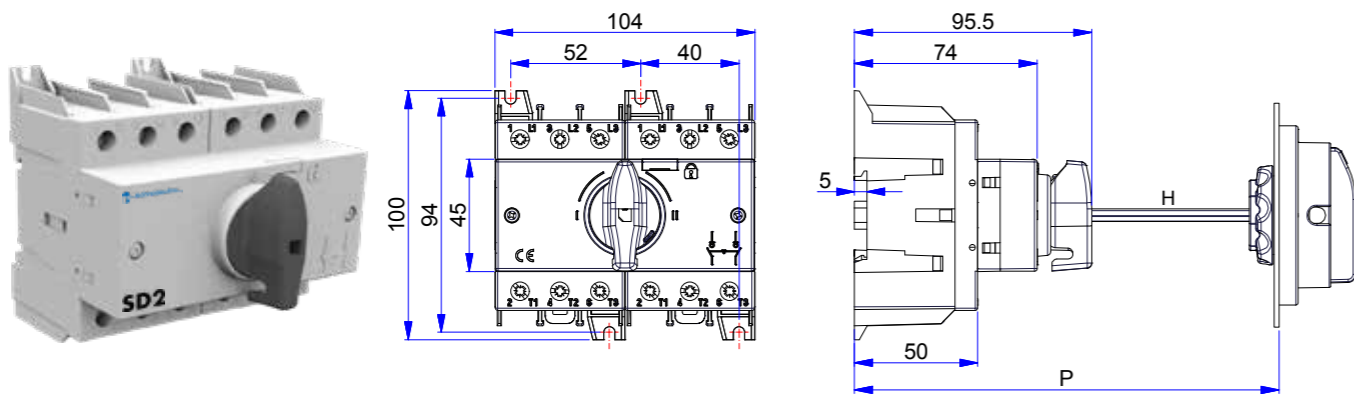

CO SD2				
HANDLE	P	C	H	
19462	--	52	P-C	
19459	--	40	P-C	

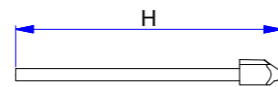

**CO SD2 OL**

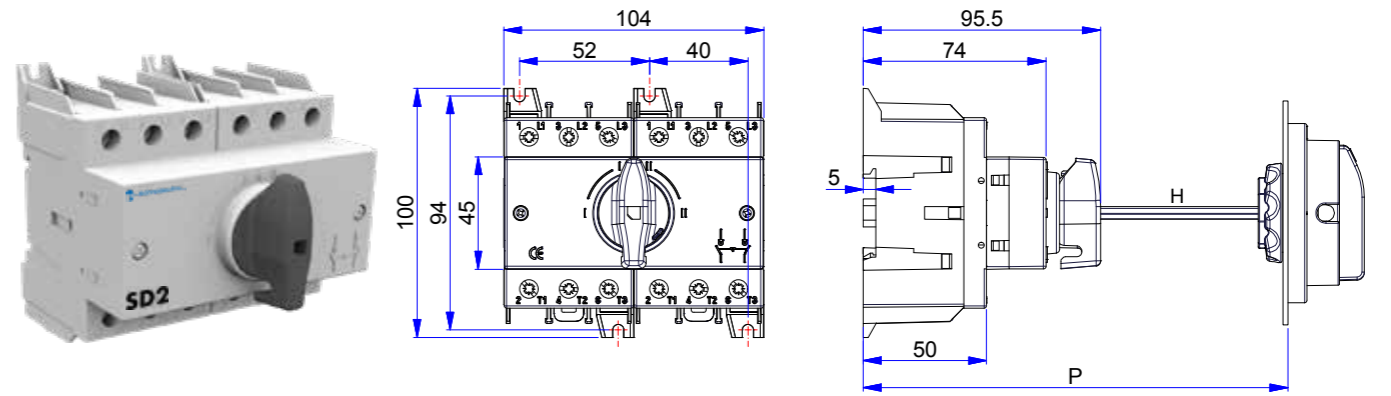

CO SD2 OL				
HANDLE	P	C	H	
19457	--	52	P-C	
19458	--	40	P-C	

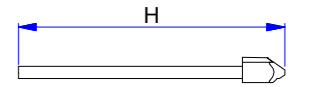

**CO SD3**

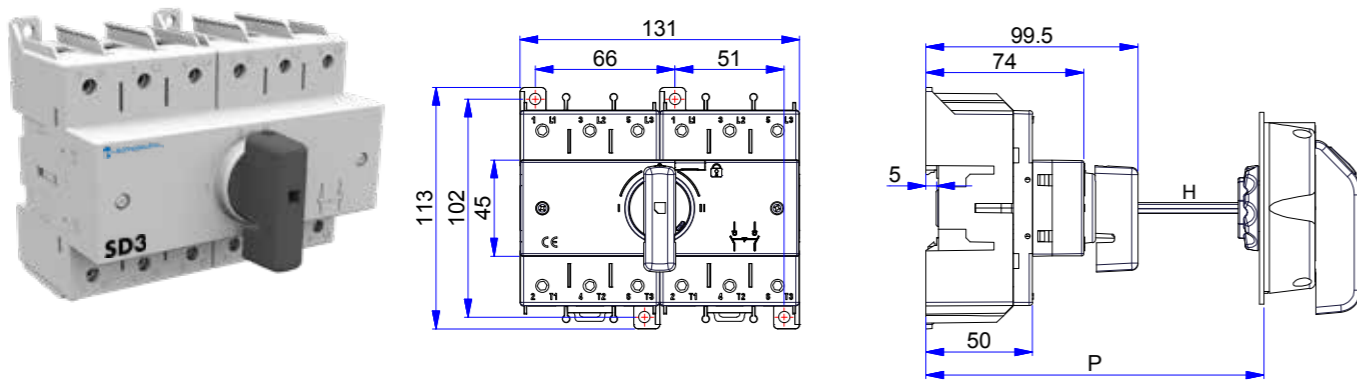

CO SD3				
HANDLE	P	C	H	
19462	--	52	P-C	
19459	--	40	P-C	

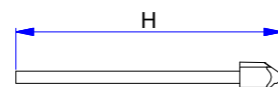

**CO SD3 OL**

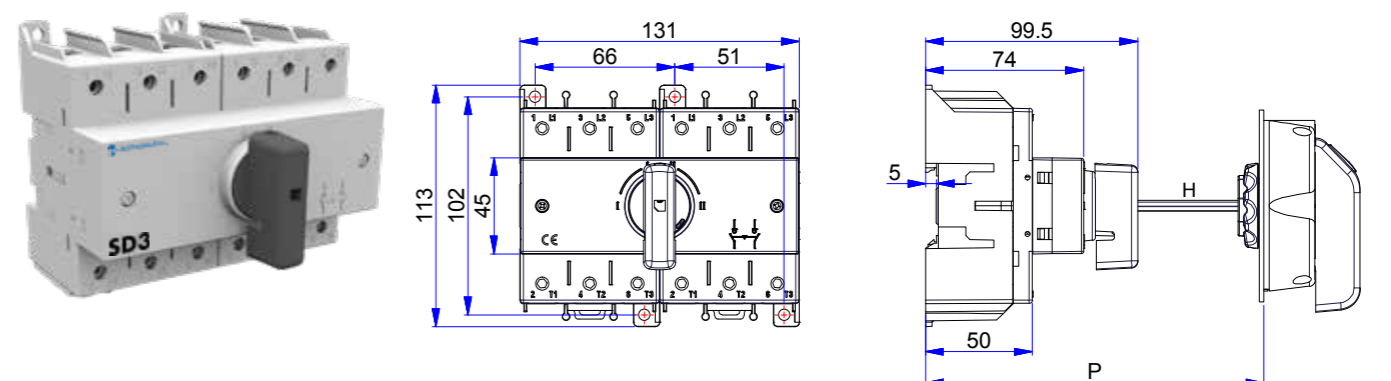

CO SD3 OL				
HANDLE	P	C	H	
19462	--	52	P-C	
19459	--	40	P-C	

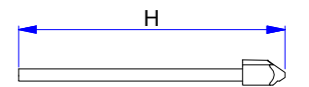

**MANIGLIE \_Door handles**  
**CO SD1 | CO SD2**

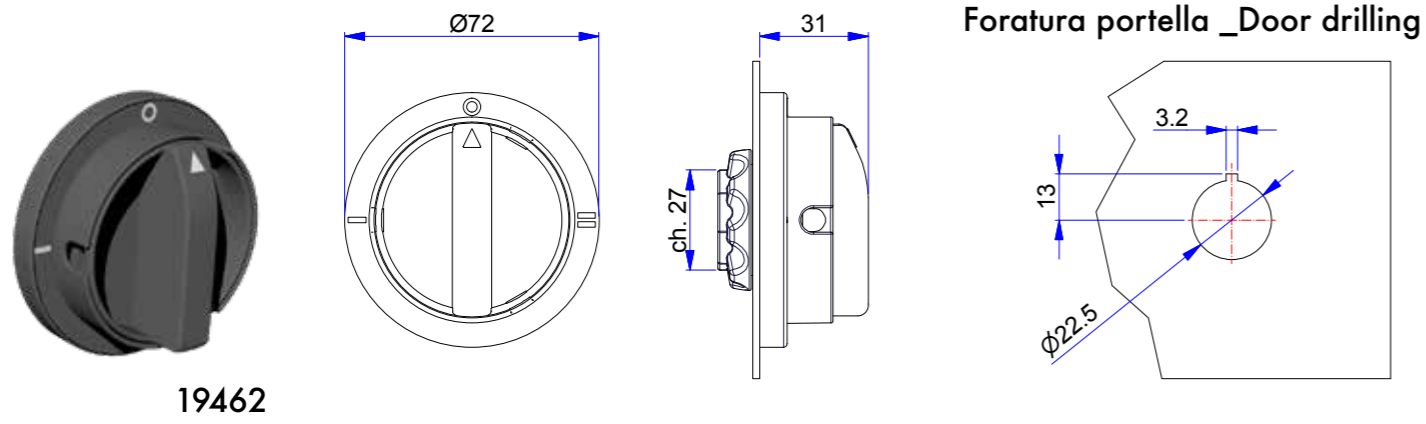

**CO SD1 OL | CO SD2 OL**

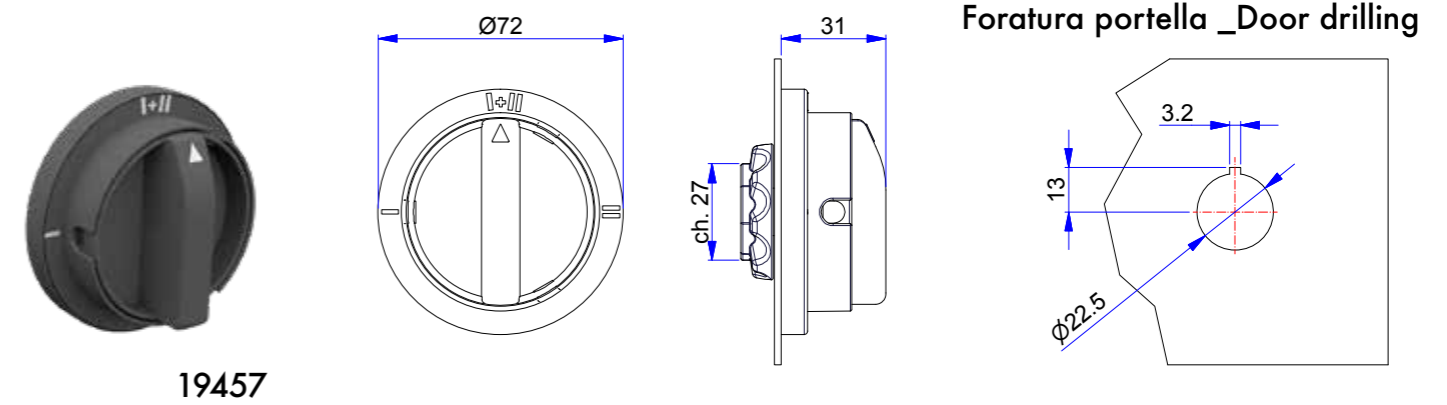

**CO SD3**

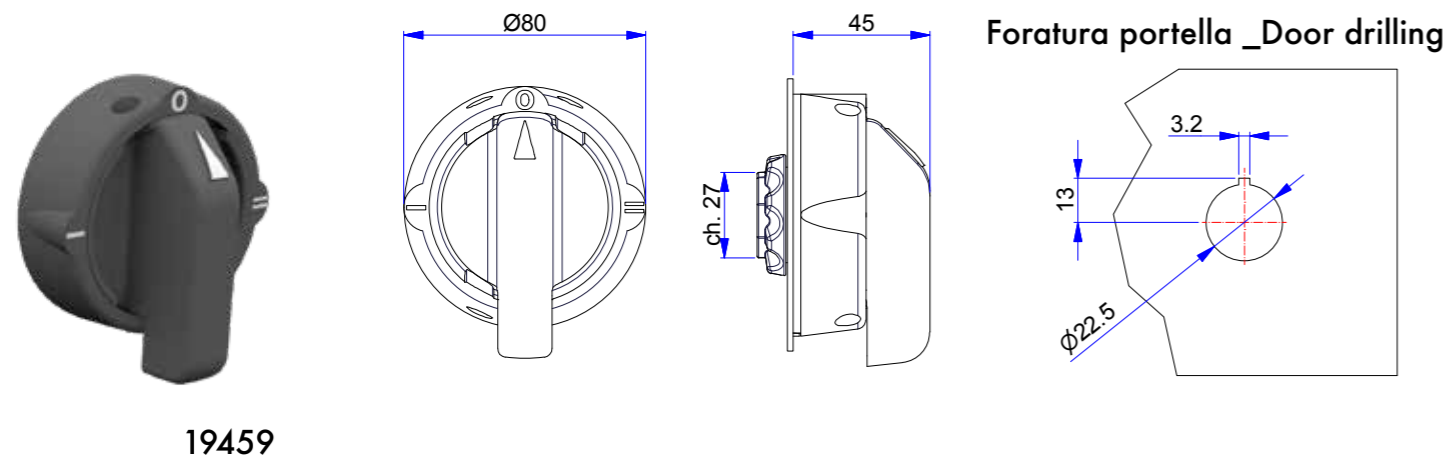

**CO SD3 OL**

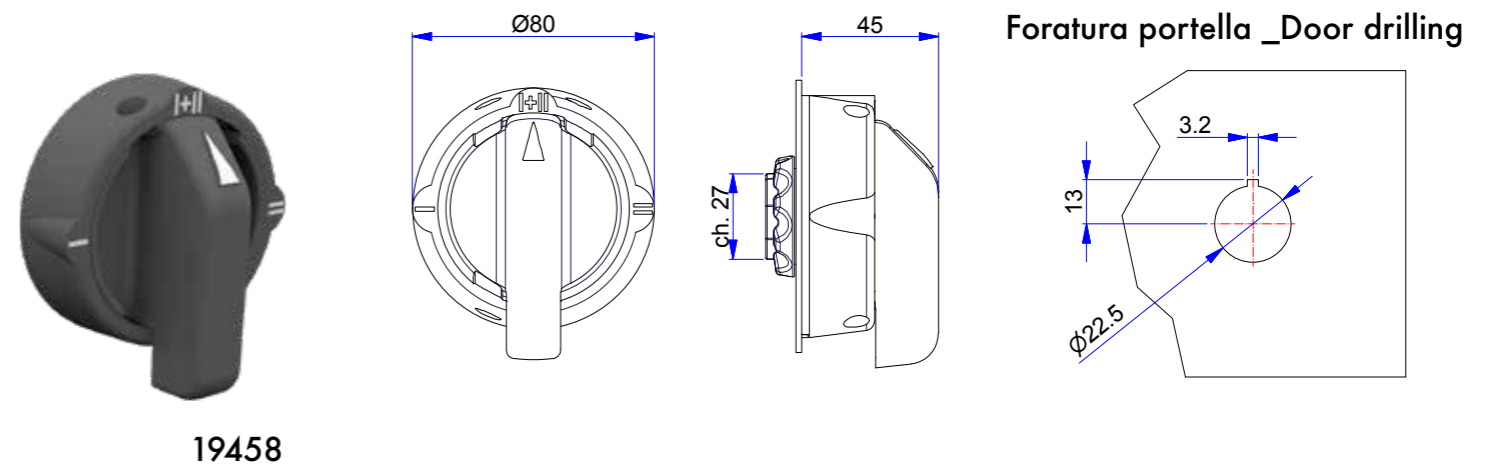

**ALBERI DI COMANDO CON PUNTALE**  
**\_shaft for external operation with tip**



Materiale \_Material  
 Acciaio \_steel

mm	100	200	300
Codice_code	19534-100P	19534-200P	19534-300P



**4° POLO NEUTRO**  
\_4th pole neutral



SD1 19320  
SD2 19418  
SD3 19450

**MORSETTO DI TERRA**  
\_Earthing neutral



SD1 19322  
SD2 19422  
SD3 19452

**CONTATTI AUSILIARI IN SCAMBIO 1NA + 1NC**  
\_Change over auxiliary contacts 1NO + 1NC



Contatti ausiliari in scambio terminali a vite  
\_Auxiliary contacts screw terminals

Tipo_type	SD1	SD2	SD3
Codice_code	19429	19429	19429

Contatti ausiliari in scambio terminali a Faston  
\_Auxiliary contacts Faston terminals

Tipo_type	SD1	SD2	SD3
Codice_code	19430	19430	19430

Per il montaggio dei contatti ausiliari addossati al 4° polo, ordinare la confezione viti cod 11190311  
\_For the installation of the auxiliary contacts on the 4th pole, please order the screws set with code 11190311

**NEUTRO PASSANTE**  
\_Solid neutral



SD1 19321  
SD2 19420  
SD3 19451

**4° POLO CONTEMPORANEO**  
\_Contemporary 4th pole



SD1 19442  
SD2 19443  
SD3 19444

Contatti ausiliari in scambio  
Apertura anticipata rispetto all'apertura dei contatti principali dell'interruttore Portata nominale 16A  
Portata termica 20A

\_Auxiliary contacts break before make contacts switches  
Rated current 16A  
Thermal current 20A

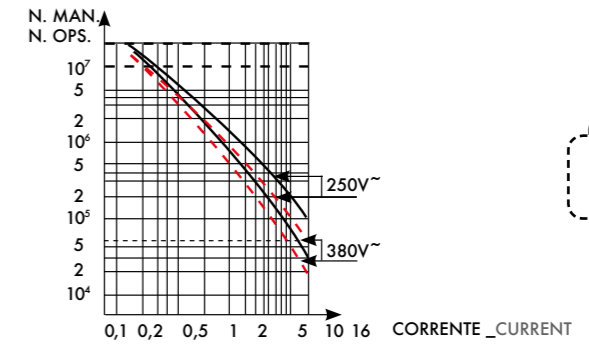

**KIT COPRI TERMINALI 4° POLO**  
\_4th pole terminals cover kit

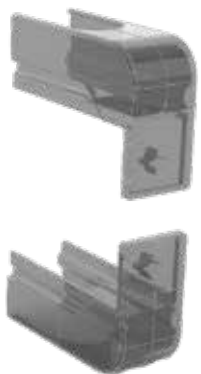

CO-SD1 19426  
CO-SD2 19427  
CO-SD3 19454

**KIT COPRI TERMINALI 3 POLI**  
\_3 poles terminals cover kit



CO-SD1 19424  
CO-SD2 19425  
CO-SD3 19453

**MORSETTO ADATTATORE 200A PER CAVI DA 95MM<sup>2</sup>**  
\_Terminal adapter for 95 mm<sup>2</sup> cables



Il codice include 3 pezzi \_3 pcs in each code

Codice\_code : 19565

Number of pole	Max. Cross section	Nominal current	Nominal voltage
1	120	200-190	690

Adattatore terminali per cavo da 95 mmq. per il collegamento di conduttori in alluminio e rame alle apparecchiature. Il corpo è in alluminio stagnato e l'alloggiamento è in poliammide.

\_Terminal Adapter for 95 sqmm cable. for connecting Al-and Cu-conductors to equipment. Body is made of tin-plated aluminium and housing is polyamid.

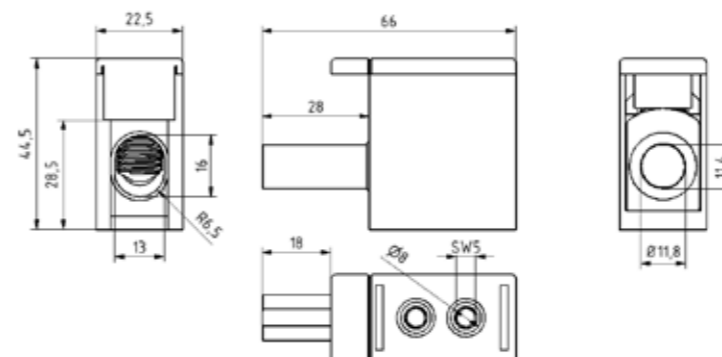



# **SEZIONATORI RETROPORTELLA**

**\_ DOOR MOUNTING SWITCHES**  
**ST 16A - 250A**

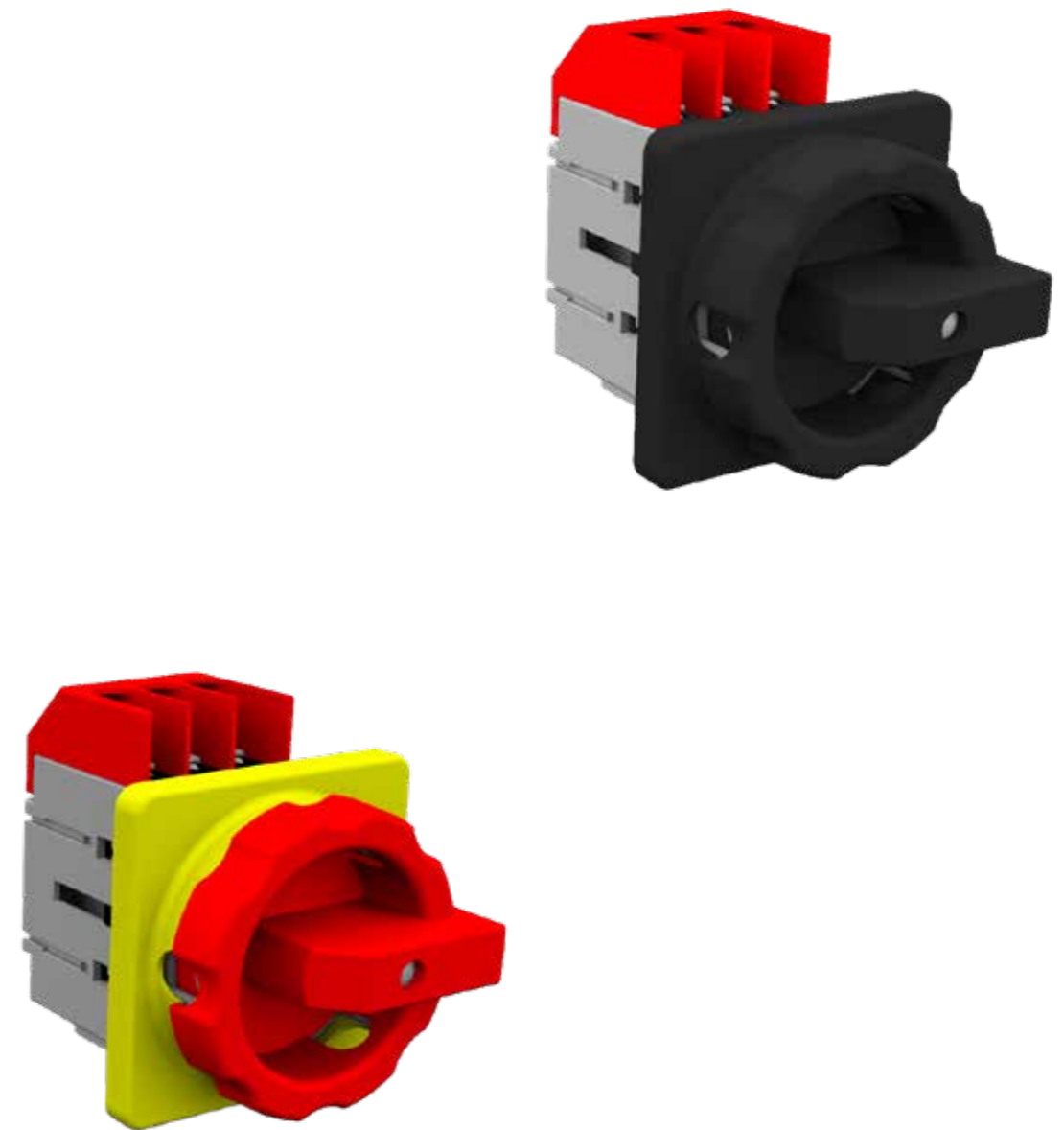

## SERIE\_SERIES ST

### GENERALITÀ

Gli interruttori-sezionatori modulari retroportella della serie ST, consentono l'interruzione e il sezionamento sotto carico di macchine e linee di bassa tensione con correnti nominali da 16 a 250 A.

### IMPIEGO

Gli apparecchi della serie ST sono abitualmente impiegati nelle seguenti funzioni:

- Interruttori di comando
- Interruttore di EMERGENZA
- Interruttore principale secondo EN 60204-1
- Sezionatore

### CARATTERISTICHE GENERALI

Alto potere d'interruzione (AC 22 A - AC 23 A)  
Costruzione compatta, ad ingombro minimo  
Doppia interruzione per ogni polo  
Elevata durata meccanica ed elettrica, contatti argentati, viti imperdibili testa croce/cacciavite  
Grado di protezione IP50 (IP65 a richiesta)  
Esecuzione modulare montaggio su portella tramite 4 viti, oppure con foro diametro 22mm( solo versione IP65)  
A vite, finestra modulare 45 mm.  
Calotta coprimorsetti inclusa

### GAMMA

ST1 16 - 25 - 32 - 40 - 63 A  
ST2 80 A  
ST3 100 - 125 A  
ST4 180 - 250 A

### POLI AGGIUNTIVI

Su ogni lato dell'interruttore possono essere installati il 4° polo N per il sezionamento del neutro, un morsetto passante, e un blocchetto di contatti ausiliari (1NA+1NC). I contatti ausiliari sono anticipati in apertura rispetto ai contatti di potenza, mentre la chiusura può essere ritardata o contemporanea.

### COMANDO

Maniglia con blocco porta, nera, o di emergenza, con possibilità di tre blocchi lucchettabili in posizione di zero

### CONDIZIONI NORMALI DI SERVIZIO, MONTAGGIO E TRASPORTO

Temperatura ambiente di immagazzinamento e trasporto - 25°C + 55°C  
Temperatura ambiente di funzionamento - 20°C + 40°C  
Per condizioni di impiego diverse consultare il costruttore.

### CONFORMITÀ ALLE NORME

IEC 60947-1|IEC 60947-3|UNI EN 60947-1|UNI EN 60947-3|UL 508A

### CERTIFICATI E OMOLOGAZIONI

UL | IEC | CSA | EAC

### GENERALITIES

The modular switch disconnectors of ST series, allow the breaking and the disconnecting on load of equipment on low voltage at nominal current from 16 to 250 A.

### USE

The switch disconnectors of ST series are commonly used for the following purposes:

- Control switches
- Emergency Switches
- Main Switches, following EN 60204-1 rules
- Disconnectors

### GENERAL CHARACTERISTICS

High breaking capacity (AC 22 A - AC 23 A)  
Double break contacts on each pole, silver plated contacts, captive screws  
High electrical and mechanical endurance  
Resistant to damp heat  
IP50 degree of protection (IP65 under request)  
Extremely compact construction,  
Modular execution, basic mounting with 4 screws, or with a 22mm diameter hole(IP65 version only)  
Contact cover included in each package

### RANGE

ST1 16 - 25 - 32 - 40 - 63 A  
ST2 80 A  
ST3 100 - 125 A  
ST4 180 - 250 A

### ADDITIONAL POLES

Fourth neutral pole makes earlier and opens later than the phase contacts. Fourth pole solid neutral.  
Earth pole. Contemporary pole under request.  
A 4<sup>th</sup> Pole (or a solid neutral), or Auxiliary contacts can be installed on each side of the switch disconnector.  
The auxiliary contacts are advanced in opening with respect to the power contacts, while the closing can be delayed or simultaneous.

### OPERATING MECHANISM

Door interlock, black or emergency handle padlockable, with up to three padlocks in 0 position.

### STANDARD SERVICE, MOUNTING AND TRANSPORT CONDITIONS

Transport and storage ambient temperature - 25°C + 55°C  
working ambient temperature - 20°C + 40°C  
For other operating conditions please contact the manufacturer.

### CONFORMITY TO STANDARDS

IEC 60947-1|IEC 60947-3|UNI EN 60947-1|UNI EN 60947-3|UL 508A

### CERTIFICATES AND APPROVALS

UL | IEC | CSA | EAC



ST1

ST2

ST3

ST4

Corrente nominale Rated current	MANIGLIA NERA _black handle code		MANIGLIA EMERGENZA _emergency handle code		MANIGLIA NERA _black handle code		MANIGLIA EMERGENZA _emergency handle code	
	POLI _POLES	CODICE / CODES	POLI _POLES	CODICE / CODES	POLI _POLES	CODICE / CODES	POLI _POLES	CODICE / CODES
16A	3	19300R	3	19310R	4	19330R	4	19350R
25A	3	19301R	3	19311R	4	19331R	4	19351R
32A	3	19302R	3	19312R	4	19332R	4	19352R
40A	3	19303R	3	19313R	4	19333R	4	19353R
63A	3	19304R	3	19314R	4	19334R	4	19354R
80A	3	19206R	3	19216R	4	19236R	4	19256R
100A	3	19207R	3	19217R	4	19237R	4	19257R
125A	3	19701R	3	19711R	4	19731R	4	19751R
180A	3	19704R	3	19714R	4	19734R	4	19754R
250A	3	19705R	3	19715R	4	19735R	4	19755R

SERIE\_SERIES ST

			ST1				ST2	ST3	ST4				
Corrente Nominale _rated operating current	I <sub>e</sub>	A	16	25	32	40	63	80	100	125	180	250	
Tensione di Esercizio _rated operating voltage	U <sub>e</sub>	V	690	690	690	690	690	690	690	690	690	690	
Tensione Nominale di isolamento _rated insulation voltage	U <sub>i</sub>	V	690	690	690	690	690	690	690	690	690	690	
Tensione Nominale Tenuta di Impulso _rated surge withstand capacity	U <sub>imp</sub>	kV	6	6	6	6	6	6	6	6	8	8	
Corrente nominale Termica a 40°C _conventional free air thermal current at 40°C	I <sub>th</sub>	A	16	25	32	40	63	80	100	125	180	250	
Corrente Nominale di Impiego _utilization category	AC-21A	415 V	A	16	25	32	40	63		100	125	180	250
		500 V	A	16	25	32	40	63		100	125	-	-
		690 V	A	16	25	32	40	63		100	125	180	250
	AC-22A	415 V	A	16	19	22	29	43		100	125	160	230
		500 V	A	-	-	-	-	-		100	125	-	-
		690 V	A	9	11	13	17	22		100	125	-	-
	AC-23A	415 V	A	16	19	22	36	43		70	80	-	224
		500 V	A	-	-	-	-	-		-	-	-	-
		690 V	A	9	11	13	17	22		34	39		55
Potere di Chiusura _rated operating power	AC23	415 V	kW	7.5	9	11.5	15	22		34	45	90	132
		500 V	kW	7.5	9	11.5	15	-		-	-	-	-
		690 V	kW	7.5	9	11.5	15	18.5		30	37	45	55
Corrente di breve durata per 1 sec _Short-circuit withstand currente 1 sec	I <sub>cw</sub>	400 V	kA	0.5	0.5	0.5	0.5	0.5	1.26	2	2	4	4
Corrente di cortocircuito condizionata da fusibile 690 V _rated conditional short-circuit current at 690 V	I <sub>cm</sub>	pk	kA	-	-	-	-	-	-	-	-	-	-
Potenza dissipata per polo _power loss per pole	tipo di fusibili	gG	A	25	25	50	50	63	80	100	125	200	250
Contatti Ausiliari _pilot switch	I <sub>cc</sub>	rms	kA	5	5	5	5	5				-	-
Dimensione cavo _cable size			W	0.5	1.1	1.8	2.2	4.5	5.5	7.5	12	36	36
Meldeshalter _pilot switch	AC 15	415 V	A	10	10	10	10	10	10	10	10	10	10
Leiterquerschnitt _cable size	flessibile _flexible		mm <sup>2</sup>	2,5 - 16	2,5 - 16	2,5 - 16	2,5 - 16	2,5 - 16	2,5-35	4,0-50	4,5-50	16-185	16-185

ST1 3x16 ÷ 63A | ST1 3x16 ÷ 63A EM

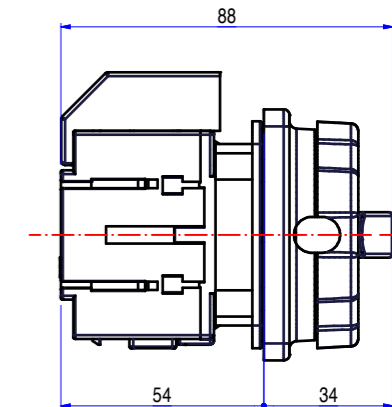
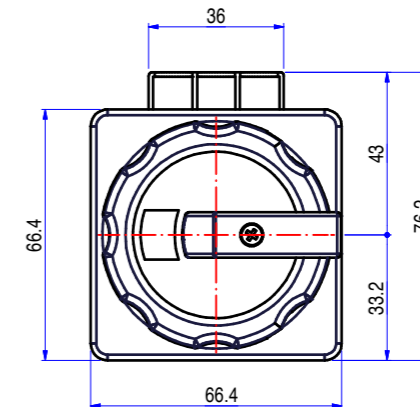

Foratura portella \_Door drilling

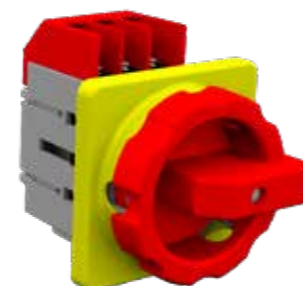
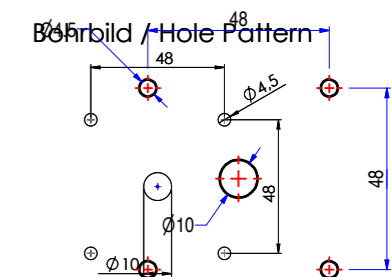

ST1 4x16 ÷ 63A | ST1 4x16 ÷ 63A EM

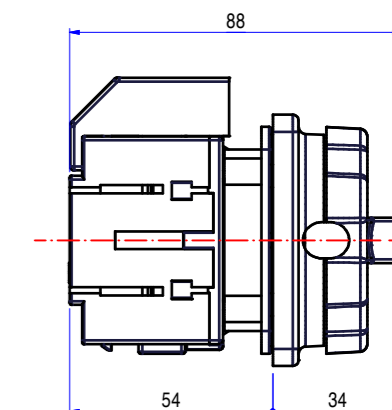
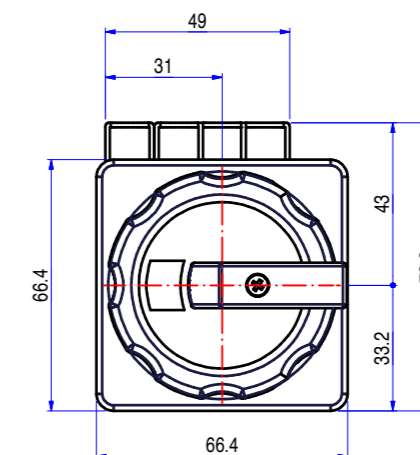

Foratura portella \_Door drilling

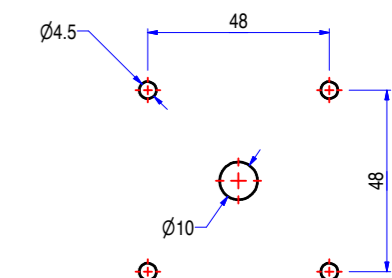



**ST2 3x80A | ST2 3x80A EM**

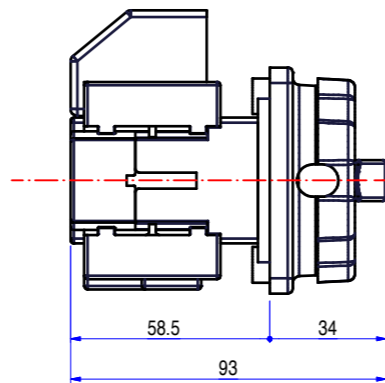
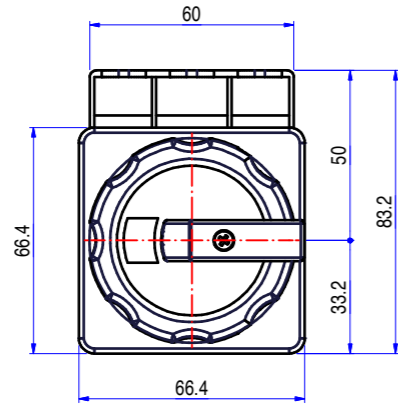

Foratura portella \_Door drilling

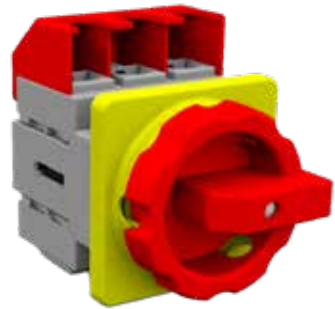
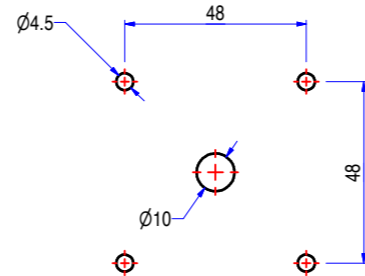

**ST3 3x100 ÷ 125A | ST1 4x100 ÷ 125A EM**

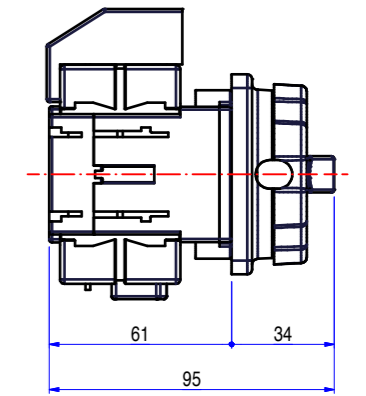
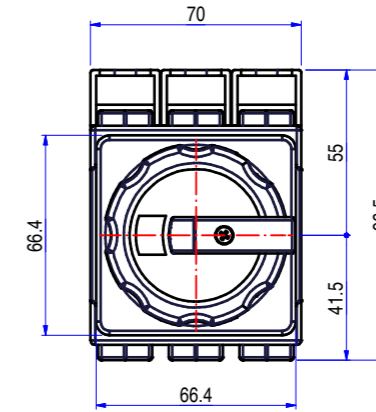

Foratura portella \_Door drilling

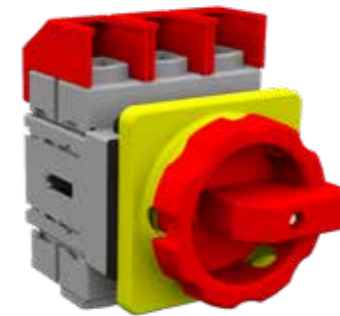
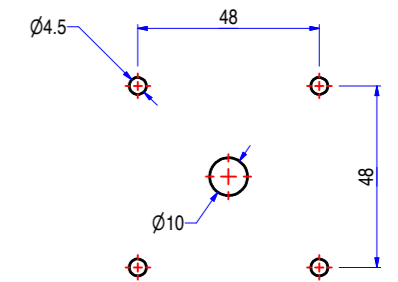

**ST2 4x80A | ST2 4x80A EM**

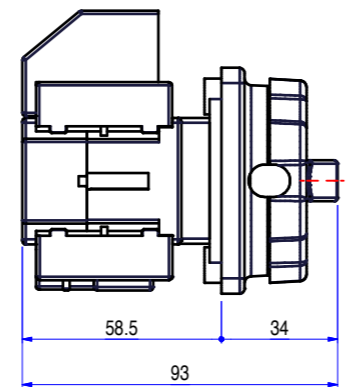
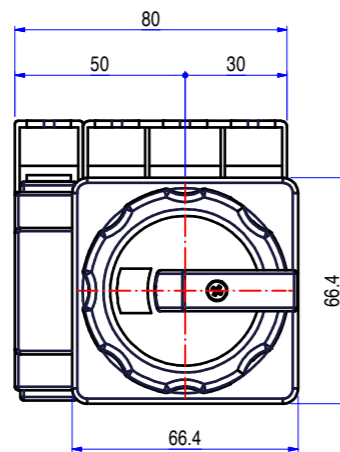
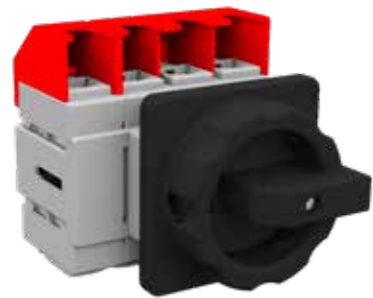

Foratura portella \_Door drilling

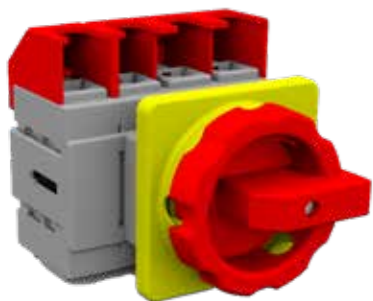
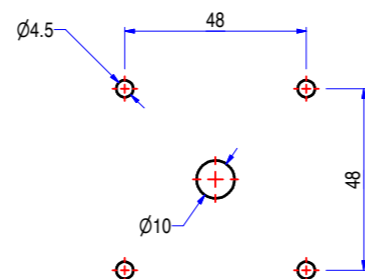

**ST3 4x100 ÷ 125A | ST3 4x100 ÷ 125A EM**

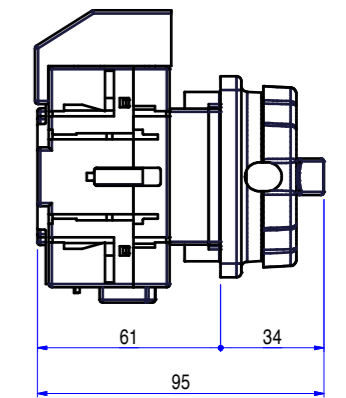
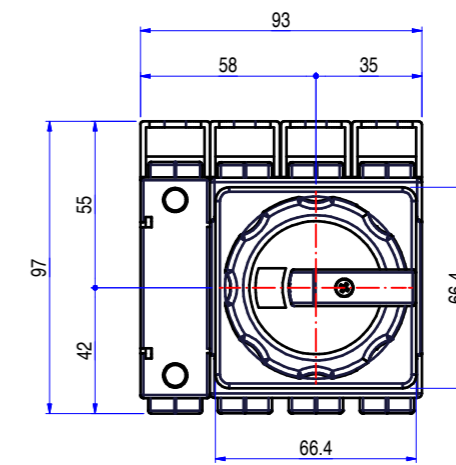

Foratura portella \_Door drilling

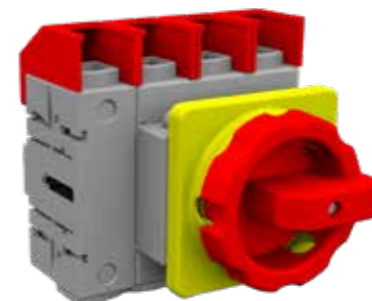
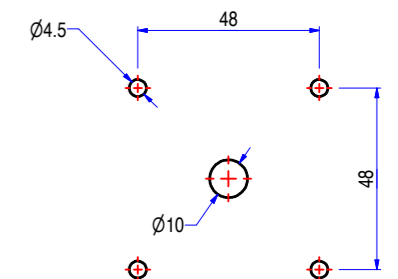

**ST4 3x180 ÷ 250A | ST4 3x180 ÷ 250A EM**

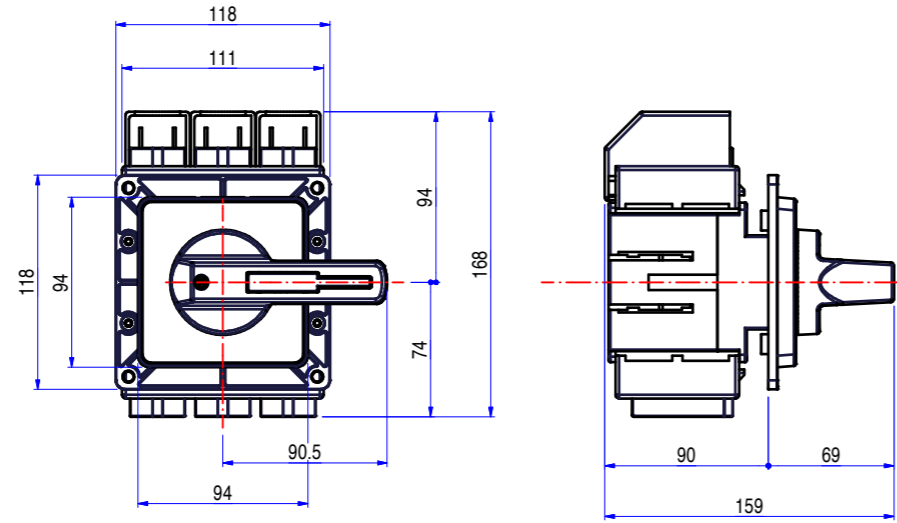
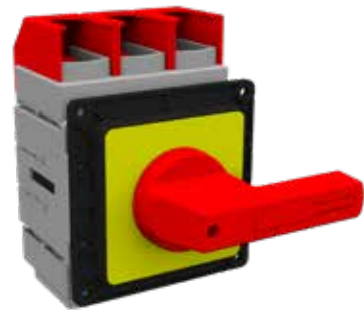
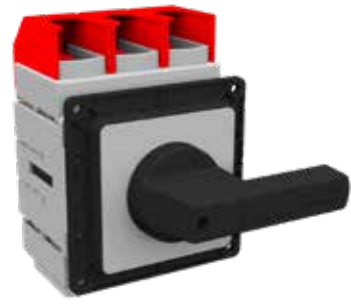

Foratura portella \_Door drilling

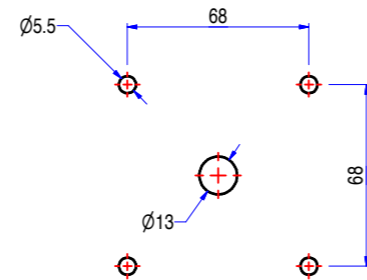

**ACCESSORI \_ACCESORIES**

Tipo _Type	A	Terra (neutro anticipato) _4th pole (make early, open late)	Terra (neutro contemporaneo) _Contemporary 4th Pole	Neutro passante _Solid neutral	Contatti ausiliari (1NA+1NA) _Aux Contacts (1NA+1NA)
<b>ST1</b>	16	19320R-NA16	19320R-NC16	19320R-SN16	19429R
	25	19320R-NA25	19320R-NC25	19320R-SN25	19429R
	32	19320R-NA32	19320R-NC32	19320R-SN32	19429R
	40	19320R-NA40	19320R-NC40	19320R-SN40	19429R
	63	19320R-NA63	19320R-NC63	19320R-SN63	19429R
<b>ST2</b>	80	19418R-NA80	19418R-NC80	19418R-SN80	19429R
<b>ST3</b>	100	19450R-NA125	19450R-NC125	19450R-SN125	19429R
	125				19429R
	125				19429R
<b>ST4</b>	180	19450R-NA250	19450R-NC250	19450R-SN250	19429R
	250				19429R

**ST4 4x180 ÷ 250A | ST4 4x180 ÷ 250A EM**

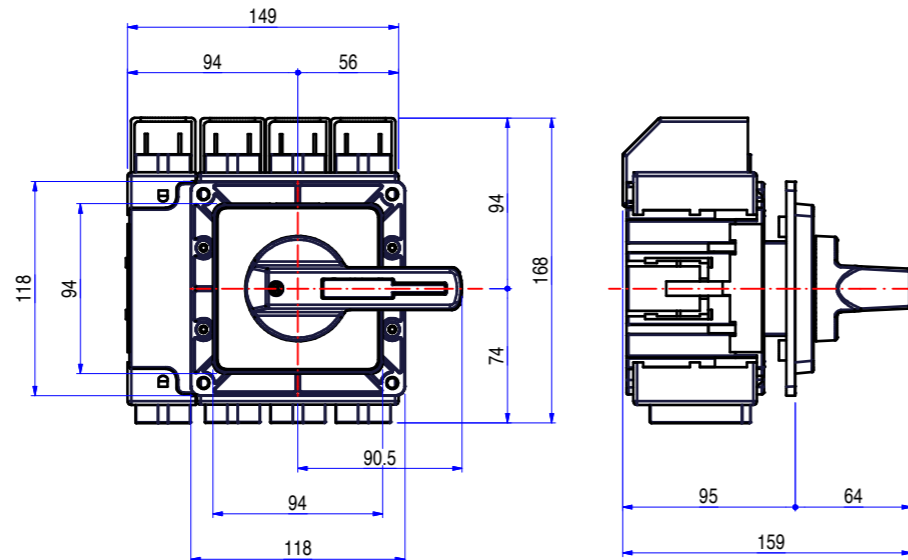
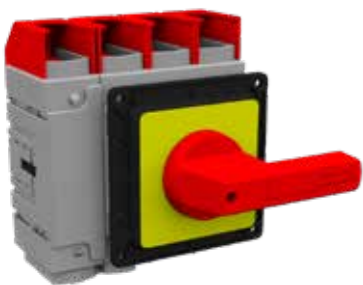

Foratura portella \_Door drilling

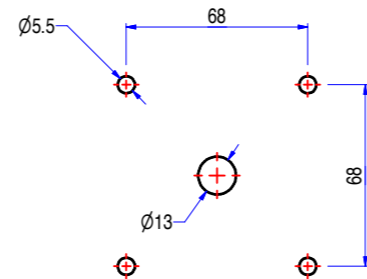

**CONTATTI AUSILIARI 1NA+1NC**  
**\_aux contacts 1NA+1NC**

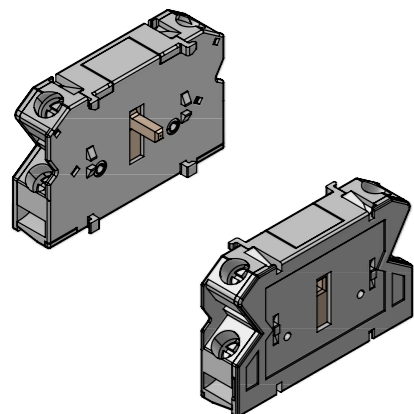

Codice \_code: 19429R

Rated insulation voltage	v	500
Thermal Uninterrupted Current	A	10
120v	A	6
220- 240v	A	3
380-415v	A	1,8
500v	A	1,4
125v	A	1,1
250v	A	0,3
solid wire	mm <sup>2</sup>	2 x0,75-4
flexible with. wire end ferrules	mm <sup>2</sup>	2 x0,75-4
Tightening torque clamps	Nm	0,8 - 1,1



# INTERRUTTORI DI MANOVRA SEZIONATORI

## SWITCH DISCONNECTORS

**VCP 32 ÷ 3150 A**

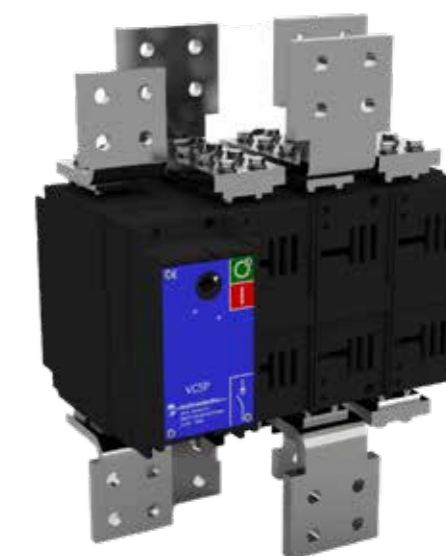





**SERIE\_SERIES VCP**

Caratteristiche tecniche _Technical Features	Tipo _Type		VC1P							VC2P			
	Corrente nominale _Rated current	In	A	32	45	63	80	100	125	160	160	200	250
Tensione nominale d'isolamento _Rated insulation voltage	Ui	V	1500	1500	1500	1500	1500	1500	1500	1500	1500	1500	1500
Tensione nominale impulso _Shock resistance	U imp	kV	8	8	8	8	8	8	8	12	12	12	12
Corrente nominale termica _Thermal current	Ith	A	32	45	63	80	100	125	160	160	200	250	315
Corrente nominale d' impiego _Rated operational current													
AC-21A/B	400V	A	32	45	63	80	100	125	125/160	160	200	250	250/315
	500V	A	32	45	63	80	100	125	125/160	160	200	250	250/315
	690V	A	32	45	63	80	100	125	125/160	160	200	250	250/315
AC-22A/B	400V	A	32	45	63	80	100	125	125/160	160	200	250	250/315
	500V	A	32	45	63	80	100	125	125/160	160	200	250	250/315
	690V	A	32	45	63	80	100	125	125/160	160	200	250	250/315
AC-23A/B	400V	A	32	45	63	80	100	125	125/160	160	200	250	250/315
	500V	A	25	35	45	63	80	100	100/100	125	160	200	200/200
	690V	A	20	30	35	45	63	80	80/80	100	125	160	160/160
DC-21A/B	220V	A	32	45	63	80	100	125	125/160	160	200	250	250/315
	420V	A	-	-	-	-	-	-	-	160	200	250	250/315
	560V	A	-	-	-	-	-	-	-	60	60	60	60
DC-22A/B	220V	A	32	45	63	80	100	125	125/160	160	200	250	250/315
	420V	A	-	-	-	-	-	-	-	160	200	250	250/250
	560V	A	-	-	-	-	-	-	-	40/60	40/60	40/60	40/60
DC-23A/B	220V	A	20	30	35	45	63	80	80/80	160	200	250	250/250
	420V	A	-	-	-	-	-	-	-	160	200	250	250/250
	560V	A	-	-	-	-	-	-	-	-	-	-	-
Potere di chiusura _Rated making capacity	400V AC23	A	320	450	630	800	1000	1250	1250	1600	2000	2500	2500
Potere di interruzione _Breaking capacity	400V AC23	A	256	360	504	640	800	1000	1000	1280	1600	2000	2000
Corrente di breve durata _Short-circuit withstand current	1 sec	kA	5	5	5	5	5	5	5	8	8	8	8
Corrente di breve durata _Short-circuit withstand current	0,25 sec	kA	10	10	10	10	10	10	10	16	16	16	16
Potere di chiusura in corto circuito _Short-circuit making capacity	400V	kA	7,5	7,5	7,5	7,5	7,5	7,5	7,5	13,5	13,5	13,5	13,5
Potenza nominale d'impiego _Rated operational power	400V AC23	kW	17	23	33	42	52	65	65	85	105	130	130
Corrente di corto circuito condizionata da fusibile _Rated fuse short-circuit current													
Tipo fusibile _Backup fuse		A	32	45	63	80	100	125	160	160	200	250	315
Valore efficace _R.M.S. value		kA	50	50	50	50	50	50	50	50	50	50	50
Valore di picco _Peak value		kA	6	9	10	12	12	15	16	16	20	25	27
Durata meccanica _Mechanical endurance		n.	12000	12000	12000	12000	12000	10000	10000	10000	10000	10000	10000
Durata elettrica _Electrical endurance		n.	3000	3000	3000	3000	3000	2000	2000	2000	2000	2000	2000/200
Potenza condensatori a 400V _Rated capacitor power at 400V		kVAR	15	20	30	40	45	50	50	70	90	110	110
Potenza dissipata per polo _Power losses for pole		W	0,1	0,2	0,4	0,7	1,1	1,7	2,7	1,6	2,4	3,8	6,0
Dimensione cavo _Cable section		mmq	10	10	16	25	35	50	70	70	95	120	185
Dimensione barre _Bars dimension		MM	10x2	10x2	12x3	12x3	14x3	16x3	16x4	20x4	20x5	20x6	22x8
Sforzi di manovra _Operating torque		Nm	8	8	8	8	8	8	8	12	12	12	12
Peso netto _Net weight	3P	Kg	0,9	0,9	0,9	0,9	0,9	0,9	0,9	1,5	1,5	1,5	1,5
	4P		1	1	1	1	1	1	1	1,6	1,6	1,6	1,6

Caratteristiche tecniche _Technical Features	Tipo _Type		VC3P			VC4P	
	Corrente nominale _Rated current	In	A	315	400	500	630
Tensione nominale d'isolamento _Rated insulation voltage	Ui	V	1500	1500	1500	1500	1500
Tensione nominale impulso _Shock resistance	U imp	kV	12	12	12	12	12
Corrente nominale termica _Thermal current	Ith	A	315	400	500	630	800
Corrente nominale d' impiego _Rated operational current							
AC-21A/B	400V	A	315	400	400/500	630	630/800
	500V	A	315	400	400/500	630	630/800
	690V	A	315	400	400/500	630	630/800
AC-22A/B	400V	A	315	400	400/500	630	630/800
	500V	A	315	400	400/400	630	630/630
	690V	A	315	400	400/400	630	630/630
AC-23A/B	400V	A	315	400	400/400	630	630/630
	500V	A	250	315	315/315	630	500/500
	690V	A	200	250	250/250	630	400/400
DC-21A/B	220V	A	315	400	400/500	630	630/800
	420V	A	315	400	400/500	630	630/800
	560V	A	315	400	400/500	630	630/800
DC-22A/B	220V	A	315	400	400/500	630	630/800
	420V	A	315	400	400/400	630	630/630
	560V	A	315	400	400/400	630	630/630
DC-23A/B	220V	A	315	400	400/400	630	630/630
	420V	A	315	400	400/400	630	630/630
	560V	A	315	400	400/400	630	630/630
Potere di chiusura _Rated making capacity	400V AC23	A	3150	4000	4000	6300	6300
Potere di interruzione _Breaking capacity	400V AC23	A	2520	3200	3200	5040	5040
Corrente di breve durata _Short-circuit withstand current	1 sec	kA	13	13	13	26,5	26,5
Corrente di breve durata _Short-circuit withstand current	0,25 sec	kA	26	26	26	53	53
Potere di chiusura in corto circuito _Short-circuit making capacity	400V	kA	26	26	26	30	30
Potenza nominale d'impiego _Rated operational power	400V AC23	kW	165	210	210	330	330
Corrente di corto circuito condizionata da fusibile _Rated fuse short-circuit current							
Tipo fusibile _Backup fuse		A	315	400	500	630	800
Valore efficace _R.M.S. value		kA	50	50	50	50	50
Valore di picco _Peak value		kA	27	30	37	40	40
Durata meccanica _Mechanical endurance		n.	8000	8000	8000	8000	8000
Durata elettrica _Electrical endurance		n.	1500	1500	1500/200	1500	1500/200
Potenza condensatori a 400V _Rated capacitor power at 400V		kVAR	140	180	180	300	300
Potenza dissipata per polo _Power losses for pole		W	5,9	9,4	14,8	15,6	25,7
Dimensione cavo _Cable section		mmq	185	2x120	2x150	2x185	2x240
Dimensione barre _Bars dimension		MM	30x6	2x25x5	2x25x5	2x40x5	2x40x6
Sforzi di manovra _Operating torque		Nm	18	18	18	34	34
Peso netto _Net weight	3P	Kg	3,5	3,5	3,5	5,5	5,5
	4P		3,8	3,8	3,8	6	6

**SERIE\_SERIES VCP**

Caratteristiche tecniche _Technical Features	Tipo _Type		VC5P				VC5P 50kA					
	Corrente nominale _Rated current	In	A	800	1000	1250	800	100	1250	1600	2000	2500
Tensione nominale d'isolamento _Rated insulation voltage	Ui	V	1500	1500	1500	1500	1500	1500	1500	1500	1500	1500
Tensione nominale impulso _Shock resistance	U imp	kV	12	12	12	12	12	12	12	12	12	12
Corrente nominale termica _Thermal current	Ith	A	800	1000	1250	800	100	1250	1600	2000	2500	3150
Corrente nominale d' impiego _Rated operational current												
AC-21A/B	400V	A	800	1000	1250	800	1000	1250	1600	2000	2500	3150
	500V	A	800	1000	1250	800	1000	1250	1600	2000	2500	3150
	690V	A	800	1000	1250	800	1000	1250	1250	1250	1250	1250
AC-22A/B	400V	A	800	1000	1250	800	1000	1250	1250	1250	-	-
	500V	A	800	1000	1250	800	1000	1250	-	-	-	-
	690V	A	800	1000	1250	800	1000	1250	-	-	-	-
AC-23A/B	400V	A	800	1000	1250	800	1000	1250	-	-	-	-
	500V	A	800	800	800	630	800	1000	-	-	-	-
	690V	A	400	400	400	500	630	800	-	-	-	-
DC-21A/B	220V	A	800	1000	1250	800	1000	1250	1600	2000	-	-
	420V	A	-	-	-	-	-	-	-	-	-	-
	560V	A	-	-	-	-	-	-	-	-	-	-
DC-22A/B	220V	A	800	1000	1250	800	1000	1250	-	-	-	-
	420V	A	-	-	-	-	-	-	-	-	-	-
	560V	A	-	-	-	-	-	-	-	-	-	-
DC-23A/B	220V	A	500	630	800	500	630	800	-	-	-	-
	420V	A	-	-	-	-	-	-	-	-	-	-
	560V	A	-	-	-	-	-	-	-	-	-	-
Potere di chiusura _Rated making capacity	400V AC23	A	8000	10000	12500	8000	10000	12500	-	-	-	-
Potere di interruzione _Breaking capacity	400V AC23	A	6400	8000	10000	6400	8000	10000	-	-	-	-
Corrente di breve durata _Short-circuit withstand current	1 sec	kA	35	35	35	50	50	50	50	50	50	50
Corrente di breve durata _Short-circuit withstand current	0,25 sec	kA	70	70	70	100	100	100	100	100	100	100
Potere di chiusura in corto circuito _Short-circuit making capacity	400V	kA	73,5	73,5	73,5	105	105	105	105	105	105	105
Potenza nominale d'impiego _Rated operational power	400V AC23	kW	420	525	630	420	525	630	630	630	-	-
Corrente di corto circuito condizionata da fusibile _Rated fuse short-circuit current												
Tipo fusibile _Backup fuse		A	800	1000	1250	800	1000	1250	-	-	-	-
Valore efficace _R.M.S. value		kA	100	100	100	100	100	100	-	-	-	-
Valore di picco _Peak value		kA	50	60	70	50	60	70	-	-	-	-
Durata meccanica _Mechanical endurance		n.	7000	7000	7000	4000	4000	4000	4000	4000	2000	2500
Durata elettrica _Electrical endurance		n.	1000	1000	1000	1000	1000	1000	500	500	500	500
Potenza condensatori a 400V _Rated capacitor power at 400V		kVAR	380	475	600	380	475	600	-	-	-	-
Potenza dissipata per polo _Power losses for pole		W	17,5	27,3	42	15,6	24,6	38,0	38,3	61,3	91,7	145,5
Dimensione cavo _Cable section		mmq	2x240	-	-	2x240	-	-	-	-	-	-
Dimensione barre _Bars dimension		MM	2x40x5	2x40x6	2x40x8	2x40x5	2x40x6	2x40x8	3x40x8	3x50x12	4x50x12	6x50x12
Sforzi di manovra _Operating torque		Nm	45	45	45	70	70	70	70	70	70	70
Peso netto _Net weight	3P	Kg	11	11	11	11	11	11	18	18	25	25
	4P		12	12	12	12	12	12	19,2	19,2	26,5	26,5

Caratteristiche tecniche _Technical Features	Tipo _Type		VC6P				
	Corrente nominale _Rated current	In	A	3150	1600	2000	2500
Tensione nominale d'isolamento _Rated insulation voltage	Ui	V	1500	1500	1500	1500	1500
Tensione nominale impulso _Shock resistance	U imp	kV	12	12	8	8	8
Corrente nominale termica _Thermal current	Ith	A	3150	1600	2000	2500	3150
Corrente nominale d' impiego _Rated operational current							
AC-21A/B	400V	A	3150	1600	2000	2500	3150
	500V	A	3150	1600	2000	2500	3150
	690V	A	1250	1250	1250	1250	1250
AC-22A/B	400V	A	-	1600	2000	2500	1600
	500V	A	-	1250	1250	1250	-
	690V	A	-	400	400	800	-
AC-23A/B	400V	A	-	1250	1250	-	-
	500V	A	-	800	800	-	-
	690V	A	-	400	400	-	-
DC-21A/B	220V	A	-	1600	2000	-	-
	420V	A	-	-	-	-	-
	560V	A	-	-	-	-	-
DC-22A/B	220V	A	-	-	-	-	-
	420V	A	-	-	-	-	-
	560V	A	-	-	-	-	-
DC-23A/B	220V	A	-	-	-	-	-
	420V	A	-	-	-	-	-
	560V	A	-	-	-	-	-
Potere di chiusura _Rated making capacity	400V AC23	A	-	12500	12500	-	-
Potere di interruzione _Breaking capacity	400V AC23	A	-	10000	10000	-	-
Corrente di breve durata _Short-circuit withstand current	1 sec	kA	50	60	60	70	70
Corrente di breve durata _Short-circuit withstand current	0,25 sec	kA	100	120	120	140	140
Potere di chiusura in corto circuito _Short-circuit making capacity	400V	kA	105	105	105	105	105
Potenza nominale d'impiego _Rated operational power	400V AC23	kW	-	630	630	-	-
Corrente di corto circuito condizionata da fusibile _Rated fuse short-circuit current							
Tipo fusibile _Backup fuse		A	-	-	-	-	-
Valore efficace _R.M.S. value		kA	-	-	-	-	-
Valore di picco _Peak value		kA	-	-	-	-	-
Durata meccanica _Mechanical endurance		n.	2500	2500	2500	2500	2500
Durata elettrica _Electrical endurance		n.	500	500	500	500	500
Potenza condensatori a 400V _Rated capacitor power at 400V		kVAR	-	780	850	1.100	1250
Potenza dissipata per polo _Power losses for pole		W	145,5	47,8	74,7	85,4	118,1
Dimensione cavo _Cable section		mmq	-	-	-	-	-
Dimensione barre _Bars dimension		MM	6x50x12	2x80x10	2x80x10	3x80x10	32x100x10
Sforzi di manovra _Operating torque		Nm	70	70	70	70	70
Peso netto _Net weight	3P	Kg	25	17	19	27	40
	4P		26,5	19	20	30	41

VC1P

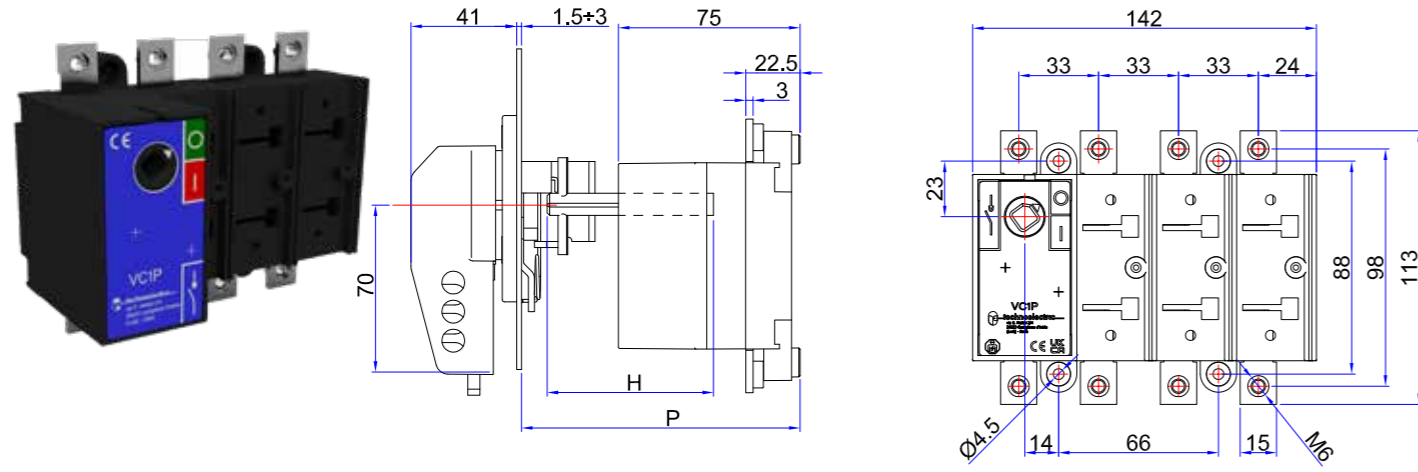

Legenda \_caption

VC1P 32 ÷ 160A

P		C	H
min	max		
116	247	47	P-C

C= costante\_ constant

Foratura portella \_Door drilling

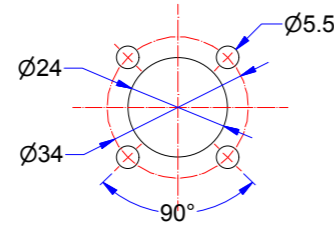

VC3P

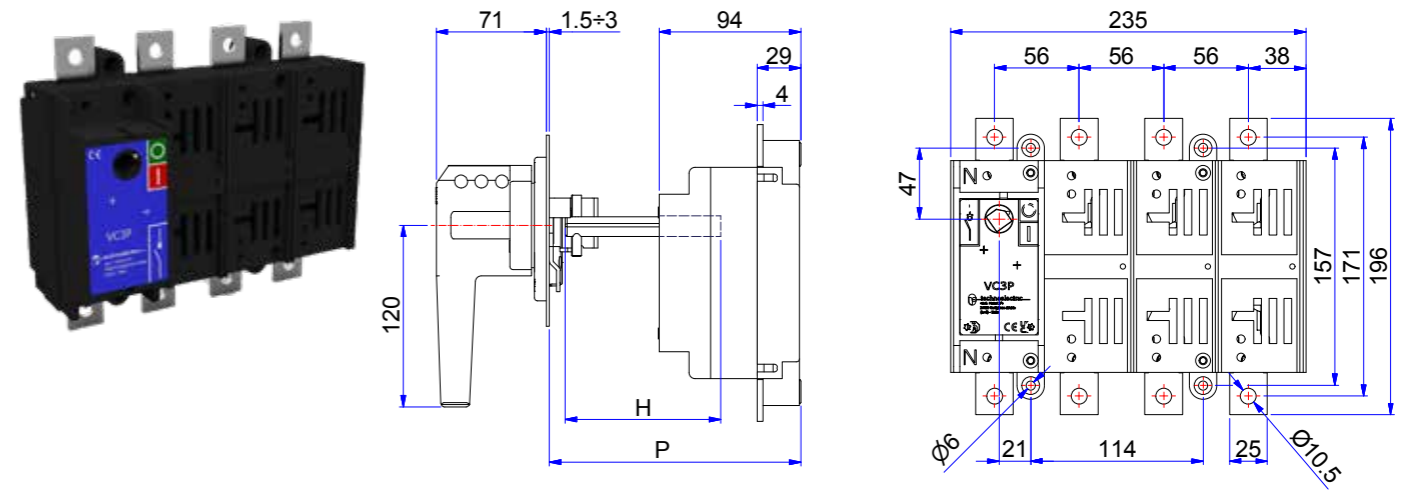

Legenda \_caption

VC3P 315 ÷ 500A

P		C	H
min	max		
148	261,5	51,5	P-C

C= costante\_ constant

Foratura portella \_Door drilling

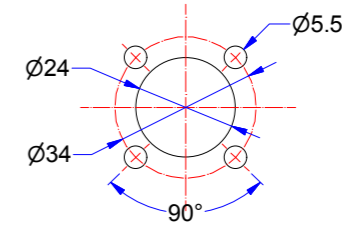

VC2P

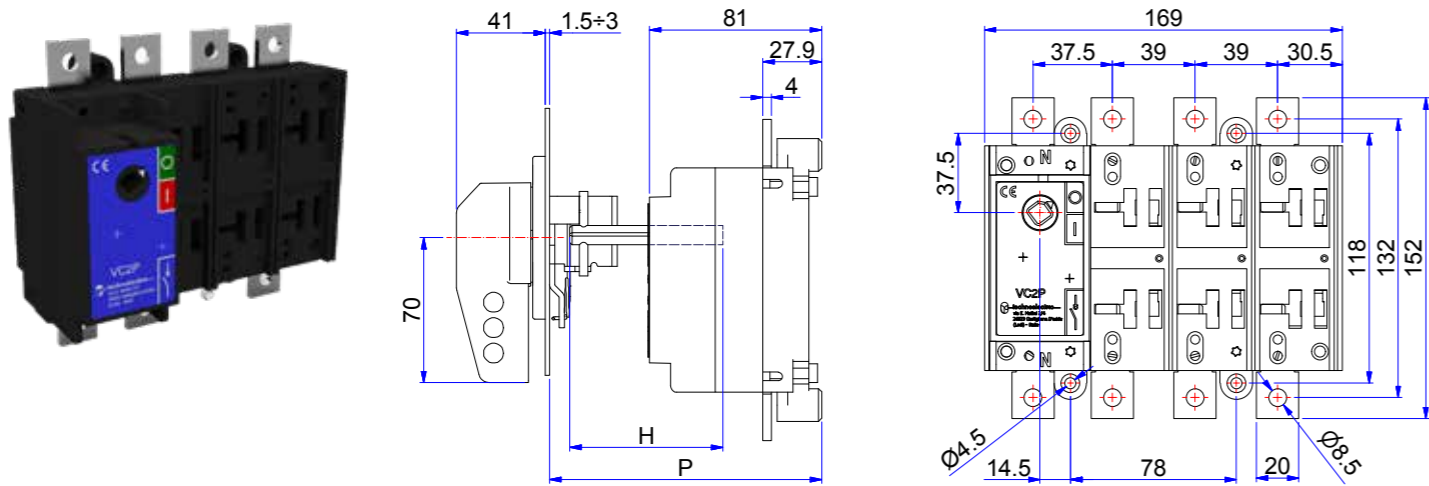

Legenda \_caption

VC2P 160 ÷ 315A

P		C	H
min	max		
124	255	55	P-C

C= costante\_ constant

Foratura portella \_Door drilling

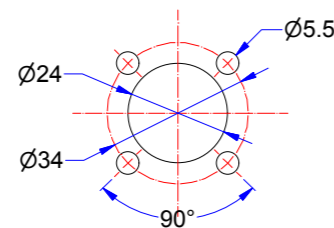

VC4P

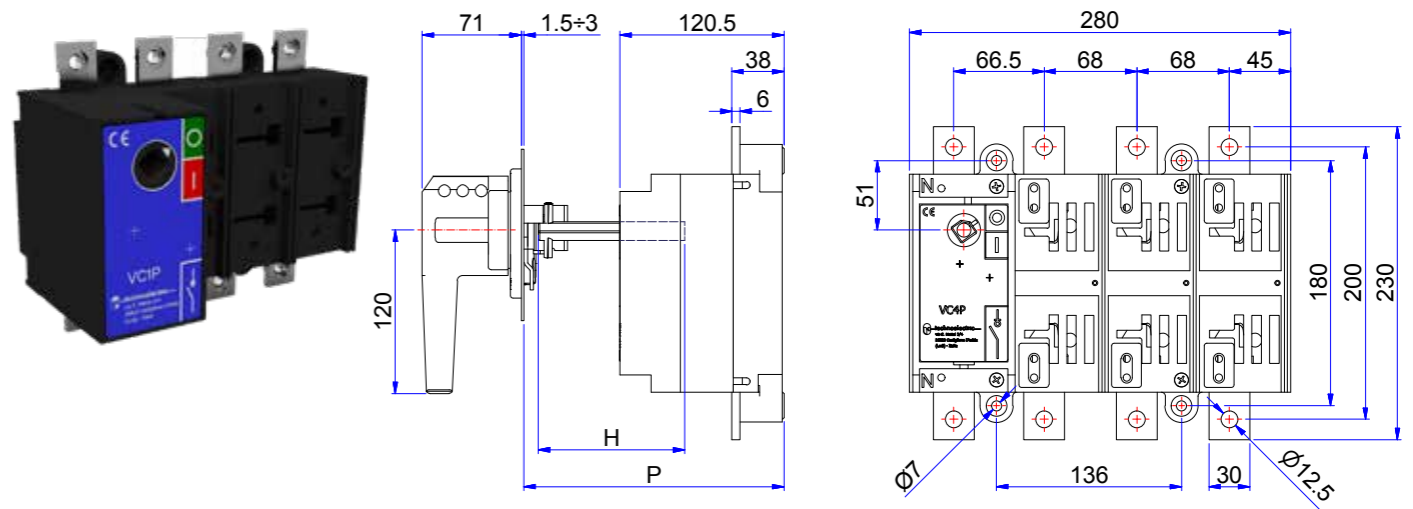

Legenda \_caption

VC4P 630 ÷ 800A

P		C	H
min	max		
174	276	76	P-C

C= costante\_ constant

Foratura portella \_Door drilling

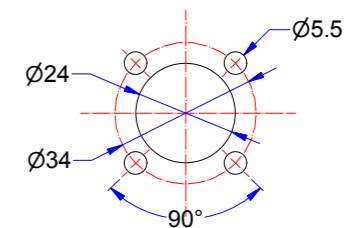



VC5P

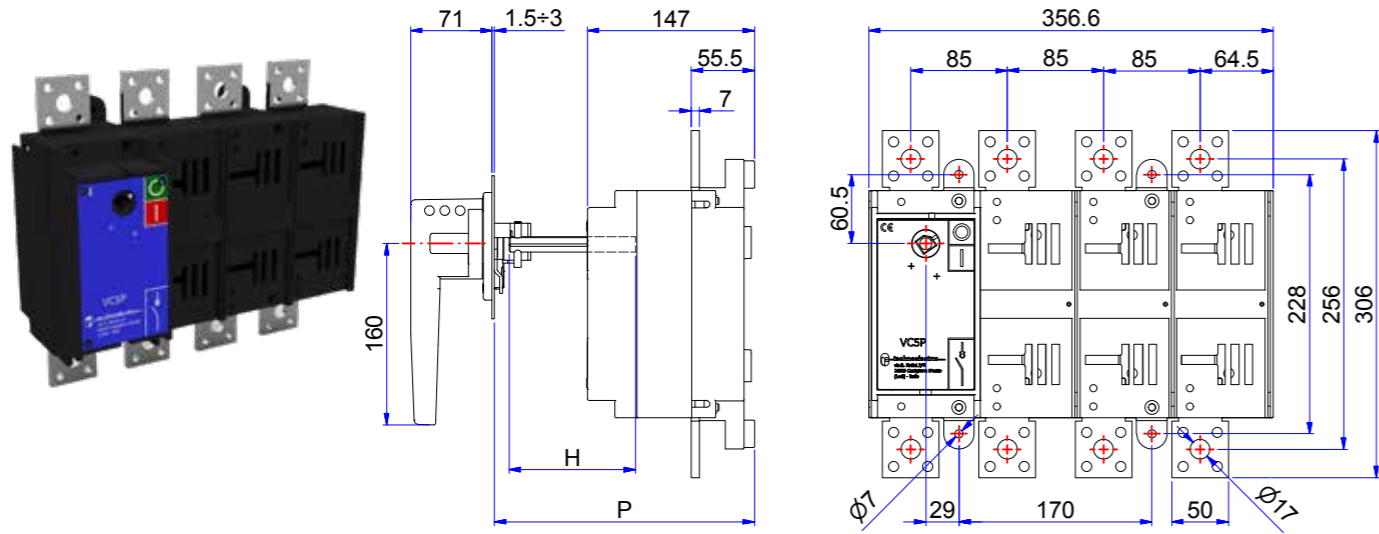

Legenda \_caption  
VC5P 800 ÷ 1250 A  
35 kA

P		C	H
min	max		
215	296	96	P-C

C= costante\_constant

Foratura portella \_Door drilling

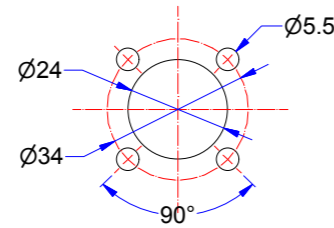

VC5P 50 kA

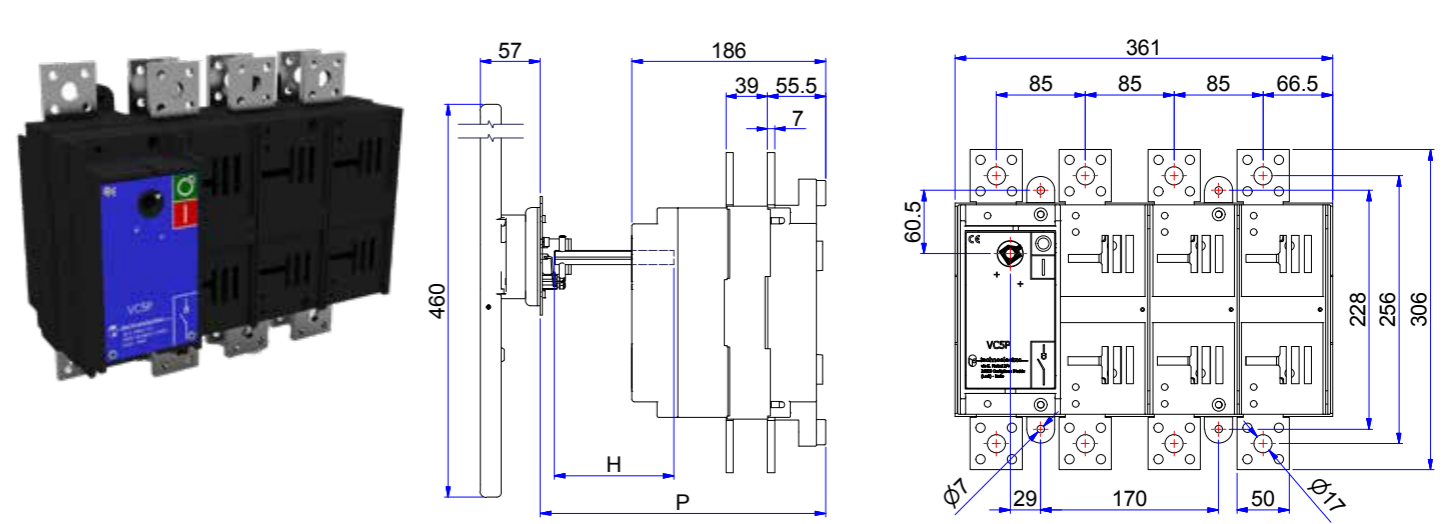

Legenda \_caption  
VC5P 1600 ÷ 2000A

P		C	H
min	max		
252	345	145	P-C

C= costante\_constant

Foratura portella \_Door drilling

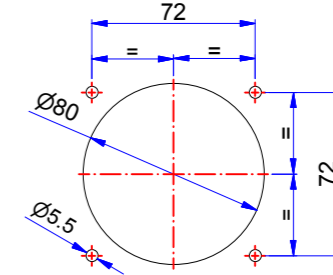

VC5P 50 kA

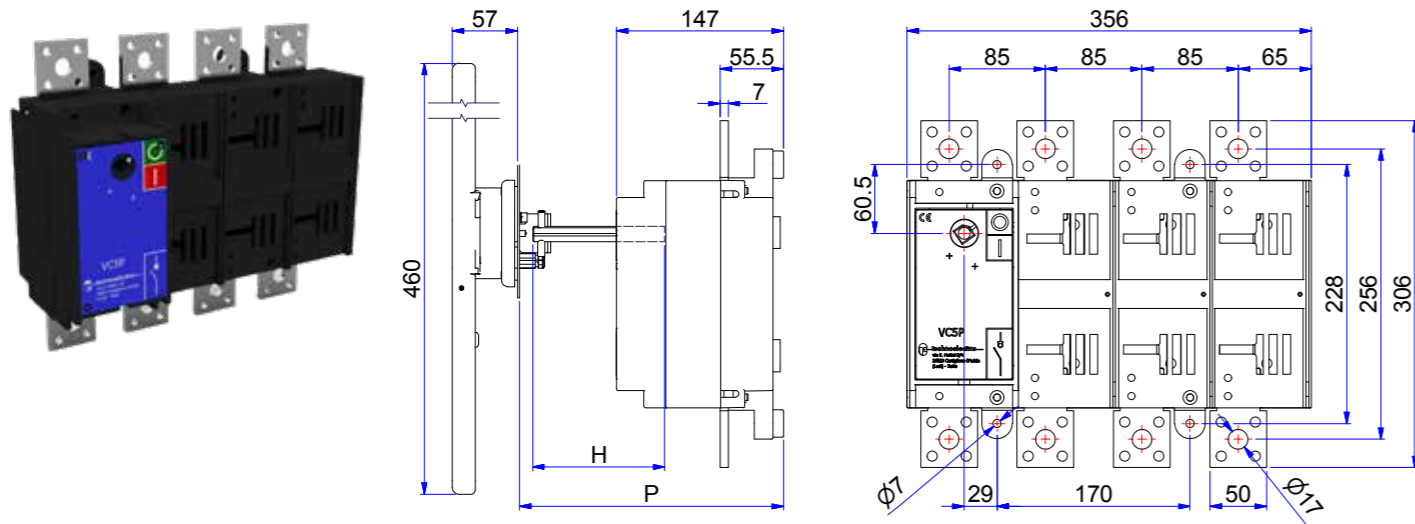

Legenda \_caption  
VC5P 800 ÷ 1250 A  
50 kA

P		C	H
min	max		
213	306	106	P-C

C= costante\_constant

Foratura portella \_Door drilling

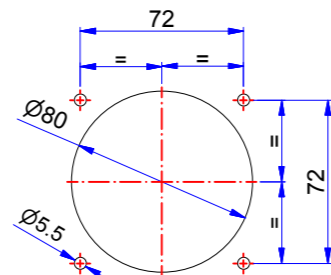

VC5P 50 kA

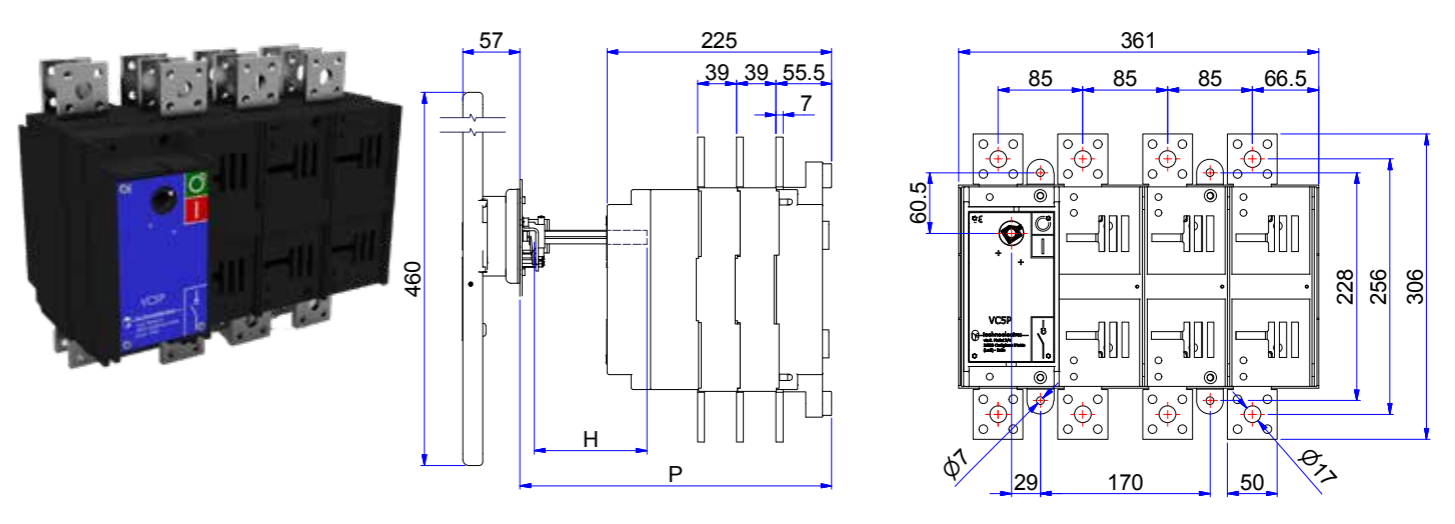

Legenda \_caption  
VC5P 2500 ÷ 3150A

P		C	H
min	max		
291	384	184	P-C

C= costante\_constant

Foratura portella \_Door drilling

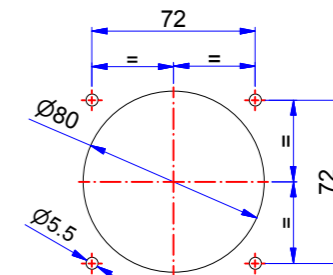

VC6P

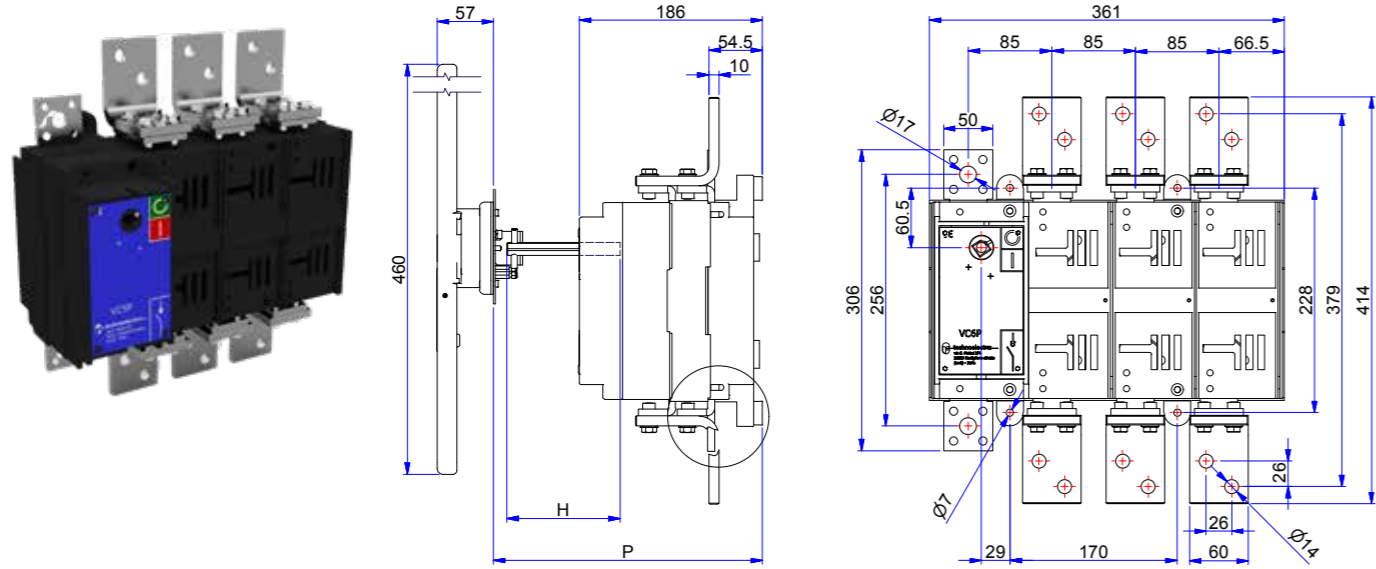

Legenda\_caption

VC6P 1600 A

P		C	H
min	max		
252	345	145	P-C

C= costante\_constant

Neutral

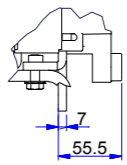

Foratura portella \_Door drilling

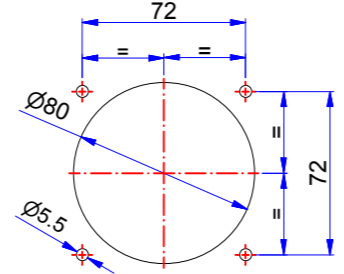

VC6P

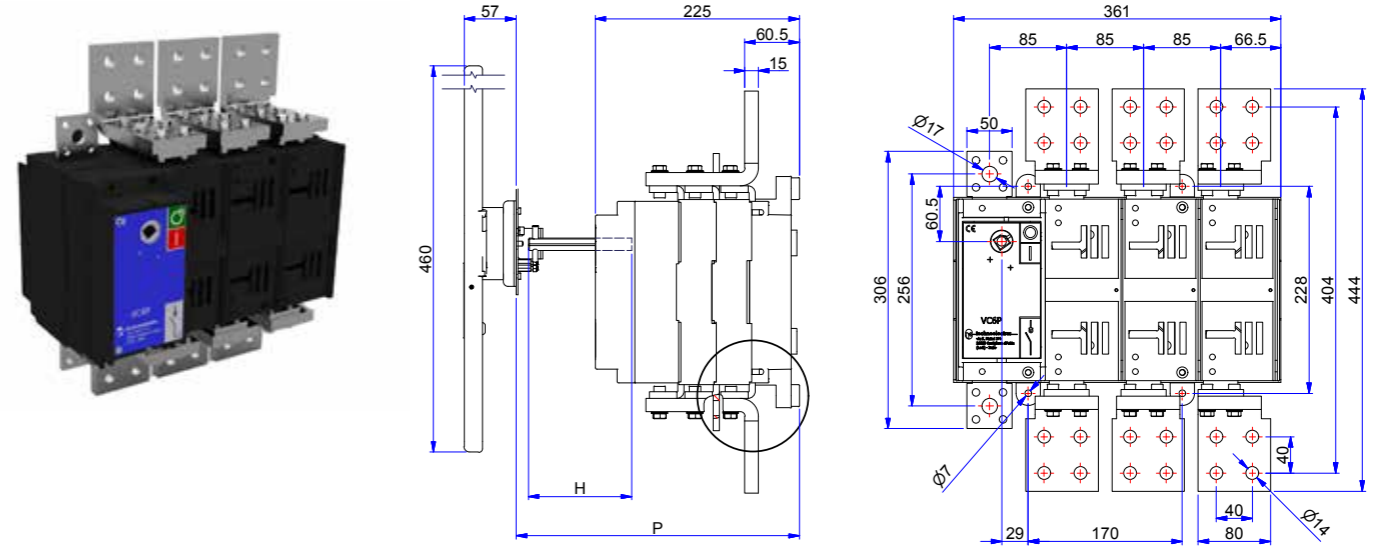

Legenda\_caption

VC6P 2500 A

P		C	H
min	max		
291	384	184	P-C

C= costante\_constant

Neutral

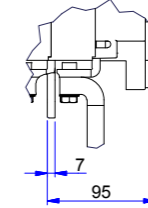

Foratura portella \_Door drilling

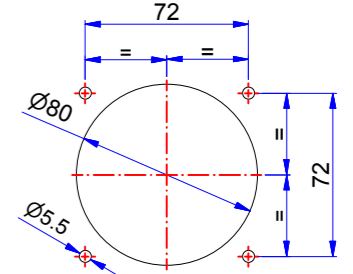

VC6P

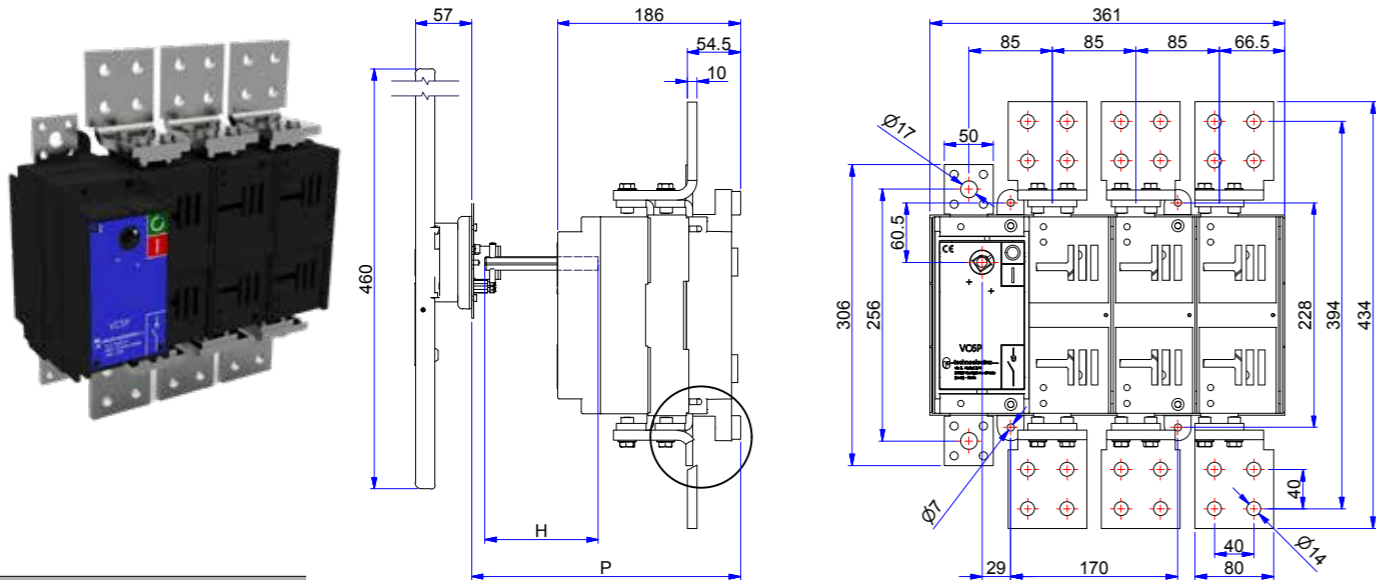

Legenda\_caption

VC6P 2000 A

P		C	H
min	max		
252	345	145	P-C

C= costante\_constant

Neutral

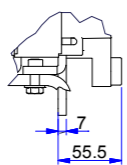

Foratura portella \_Door drilling

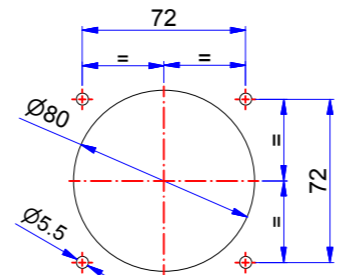

VC6P

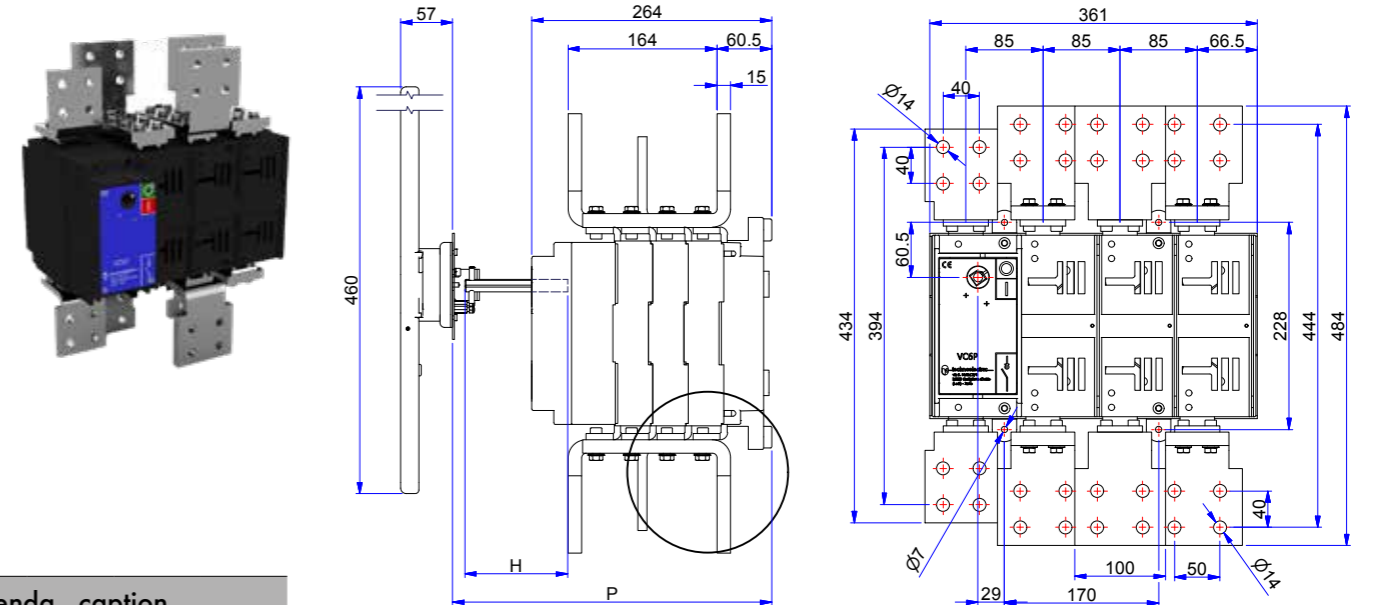

Legenda\_caption

VC6P 3150 A

P		C	H
min	max		
330	423	223	P-C

C= costante\_constant

Neutral

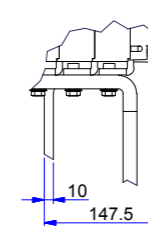

Foratura portella \_Door drilling

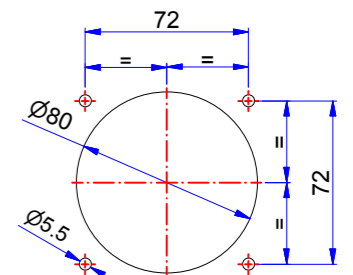

**EOP orizzontale | 6 - 8 poli**

**GENERALITÀ**

Gli interruttori 6 - 8 poli della serie VISUALCOMPACT P sono realizzati attraverso l'inter blocco meccanico di due selettori standard (vedi caratteristiche VCP).

Sono disponibili in 16 valori di corrente nominale  
Pronto per l'installazione

**EOP horizontal | 6 - 8 poles**

**GENERALITIES**

The range of 6 - 8 poles switches VISUALCOMPACT P are made by two standard switches (see VCP characteristics) Mechanical interlocked.

They are available in 16 current ratings  
Delivered already assembled



**EO1P**



**EO2P**



**EO3P**

**EO4P**

**EO5P  
(35kA)**

Tipo _type	Corrente nominale _rated current	Senza maniglia _without handle		Maniglia blocco porta _door interlock handle		
		POLI _POLES	CODICE _CODES	POLI _POLES	CODICE _CODES	
EO1P	32 A	6	110006SM	6	110006	
		8	110106SM	8	110106	
	45A	6	110016SM	6	110016	
		8	110116SM	8	110116	
	63A	6	110026SM	6	110026	
		8	110126SM	8	110126	
	80A	6	110036SM	6	110036	
		8	110136SM	8	110136	
	100A	6	110046SM	6	110046	
		8	110146SM	8	110146	
	125A	6	110056SM	6	110056	
		8	110156SM	8	110156	
	160A	6	110066SM	6	110066	
		8	110166SM	8	110166	
	EO2P	160A	6	120016SM	6	120016
			8	120116SM	8	120116
200A		6	120026SM	6	120026	
		8	120126SM	8	120126	
250A		6	120036SM	6	120036	
		8	120136SM	8	120136	
315A		6	120046SM	6	120046	
		8	120146SM	8	120146	
EO3P	315A	6	130016SM	6	130016	
		8	130116SM	8	130116	
	400A	6	130026SM	6	130026	
		8	130126SM	8	130126	
	500A	6	130036SM	6	130036	
		8	130136SM	8	130136	
	EO4P	630A	6	140036SM	6	140036
			8	140136SM	8	140136
800A		6	140046SM	6	140046	
		8	140146SM	8	140146	
EO5P (35kA)	800A	6	150006SM	6	150006	
		8	150106SM	8	150106	
	1000A	6	150016SM	6	150016	
		8	150116SM	8	150116	
	1250A	6	150026SM	6	150026	
		8	150126SM	8	150126	

Possibilità di esecuzione per EO con fusibili.  
\_Version for EO with fuses available.

**ESP sovrapposti | 6 - 8 poli**

**GENERALITÀ**

Gli interruttori 6 - 8 poli della serie VISUALCOMPACT P sono ottenuti da due sezionatori standard (vedi caratteristiche VCP) interbloccati meccanicamente.

Sono disponibili in 16 valori di corrente nominale  
Pronto per l'installazione



**ES1P**



**ES2P**



**ES3P**

**ES4P**

**ES5P  
(35kA)**

Tipo _type	Corrente nominale _rated current	Senza maniglia _without handle		Maniglia blocco porta _door interlock handle		
		POLI _POLES	CODICE _CODES	POLI _POLES	CODICE _CODES	
ES1P	32 A	6	110009SM	6	110009	
		8	110109SM	8	110109	
	45A	6	110019SM	6	110019	
		8	110119SM	8	110119	
	63A	6	110029SM	6	110029	
		8	110129SM	8	110129	
	80A	6	110039SM	6	110039	
		8	110139SM	8	110139	
	100A	6	110049SM	6	110049	
		8	110149SM	8	110149	
	125A	6	110059SM	6	110059	
		8	110159SM	8	110159	
	160A	6	110069SM	6	110069	
		8	110169SM	8	110169	
	ES2P	160A	6	120019SM	6	120019
			8	120119SM	8	120119
200A		6	120029SM	6	120029	
		8	120129SM	8	120129	
250A		6	120039SM	6	120039	
		8	120139SM	8	120139	
315A		6	120049SM	6	120049	
		8	120149SM	8	120149	
ES3P	315A	6	130019SM	6	130019	
		8	130119SM	8	130119	
	400A	6	130029SM	6	130029	
		8	130129SM	8	130129	
	500A	6	130039SM	6	130039	
		8	130139SM	8	130139	
	ES4P	630A	6	140039SM	6	140039
			8	140139SM	8	140139
800A		6	140049SM	6	140049	
		8	140149SM	8	140149	
ES5P (35kA)	800A	6	150009SM	6	150009	
		8	150109SM	8	150109	
	1000A	6	150019SM	6	150019	
		8	150119SM	8	150119	
	1250A	6	150029SM	6	150029	
		8	150129SM	8	150129	

**\_ESP two layers | 6 - 8 poles**

**GENERALITIES**

The range of 6 - 8 poles switches VISUALCOMPACT P are made by two standard switches (see VCP characteristics) Mechanical interlocked.

They are available in 16 current ratings  
Delivered already assembled

**EO1P 32 - 160 A**

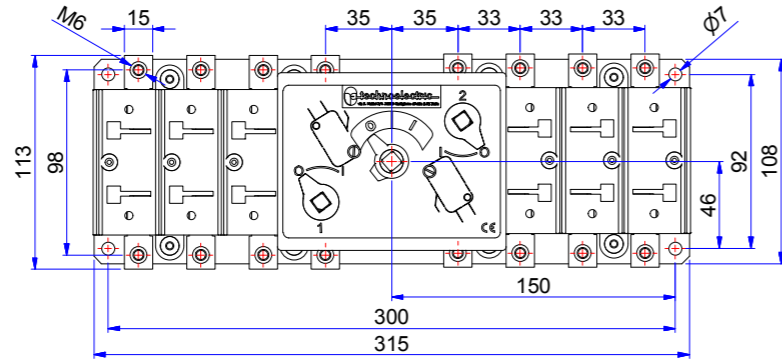
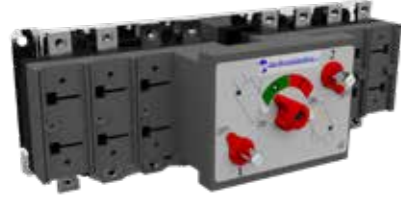

Foratura portella \_Door drilling

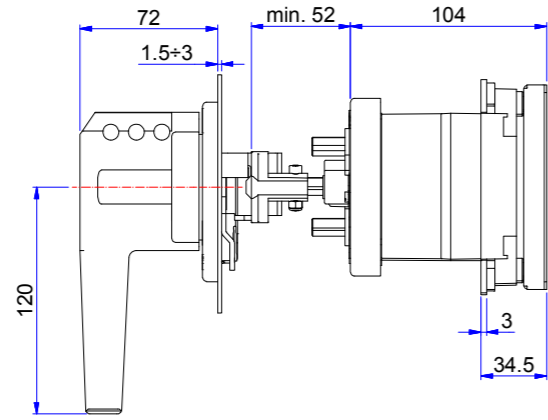
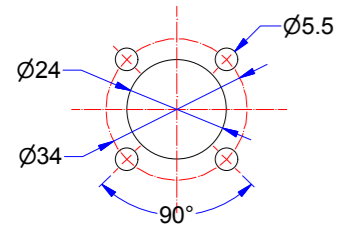

**EO3P 315 - 500 A**

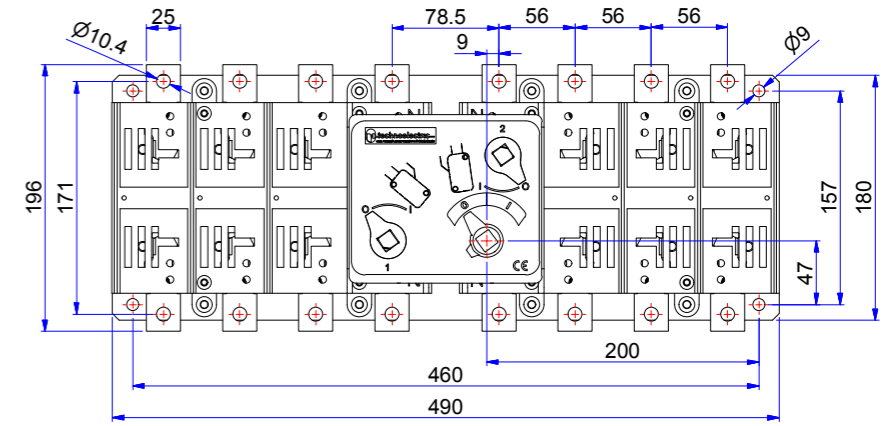
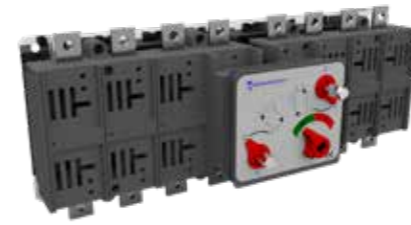

Foratura portella \_Door drilling

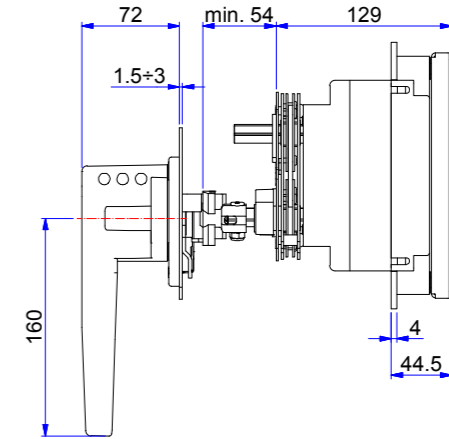
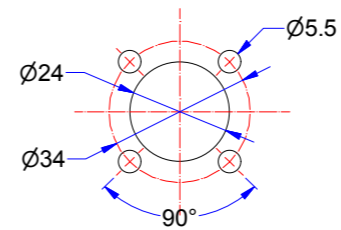

**EO2P 160 - 315 A**

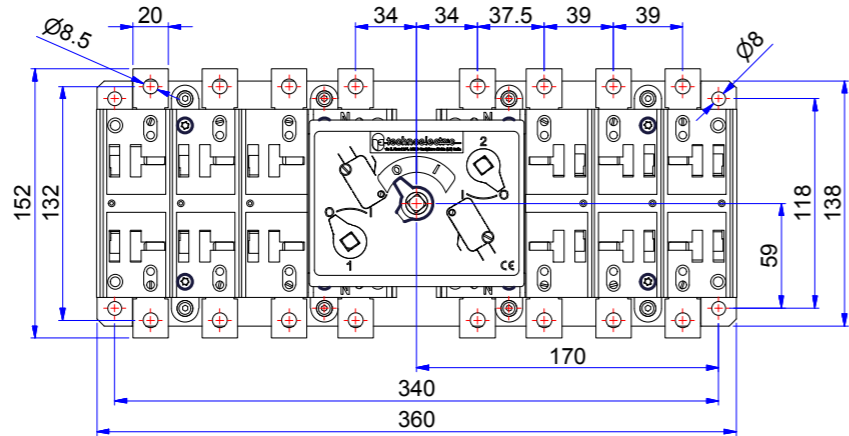

Foratura portella \_Door drilling

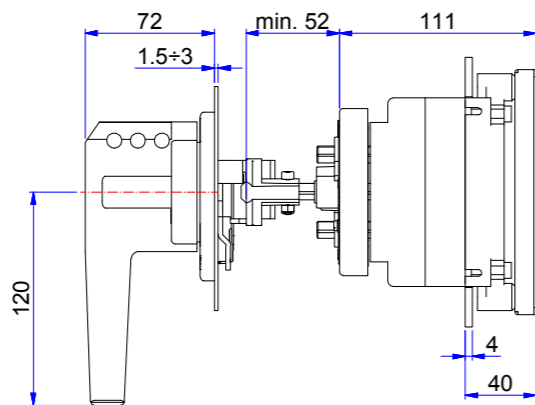
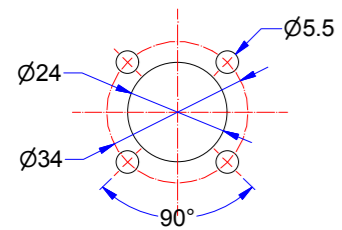

**EO4P 630 - 800 A**

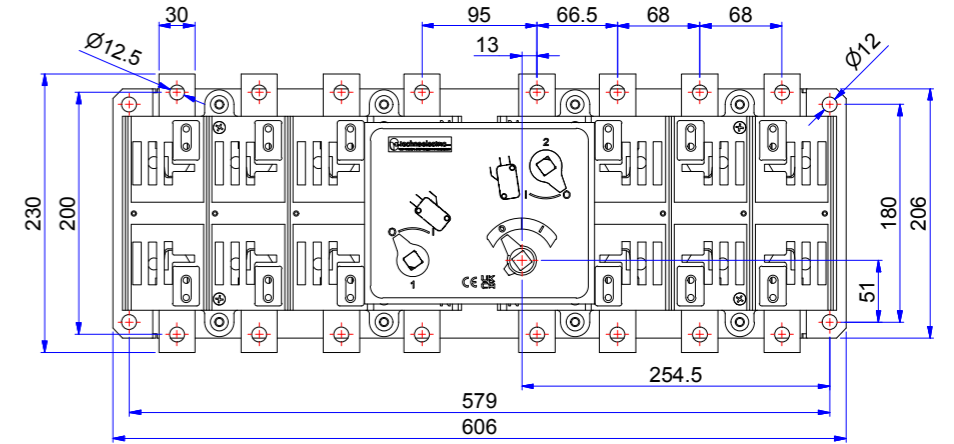

Foratura portella \_Door drilling

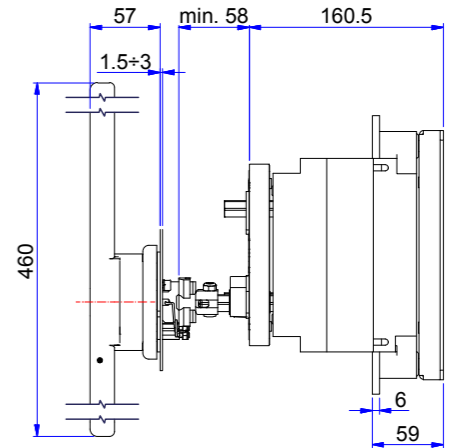
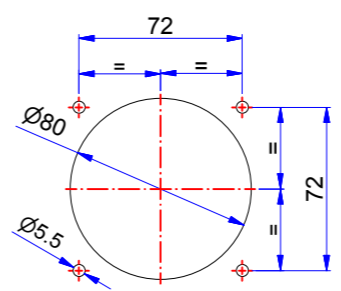



**EO5P 800 - 1250 A 35 kA**

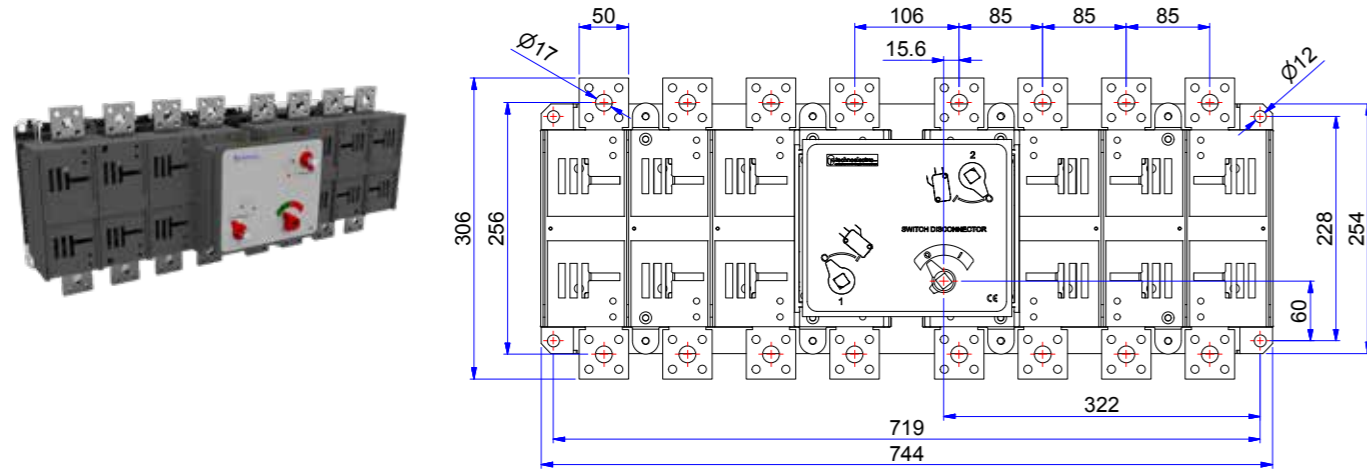

Foratura portella \_Door drilling

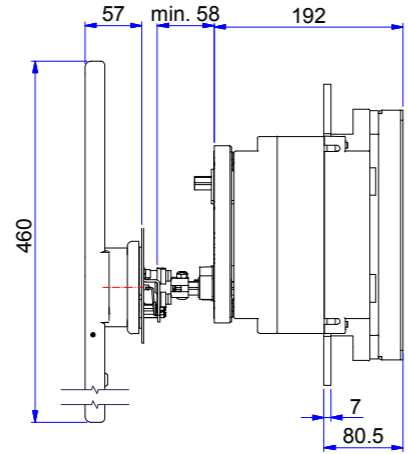
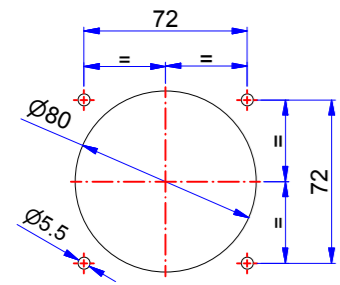

**ES2P 160 - 315 A**

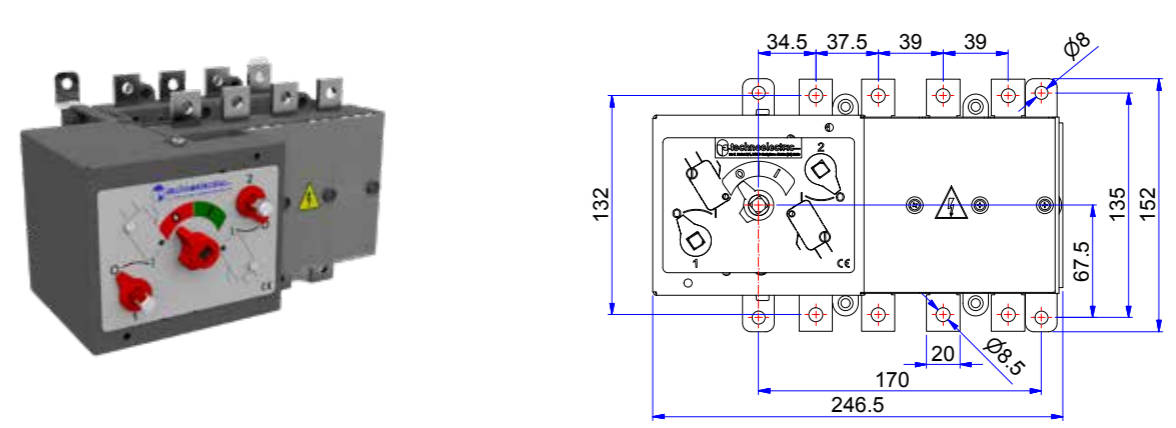

Foratura portella \_Door drilling

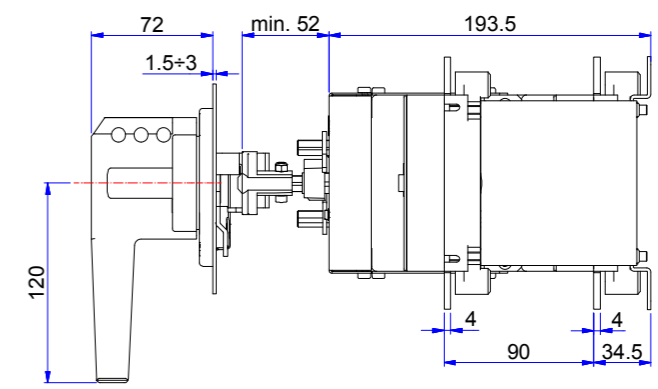
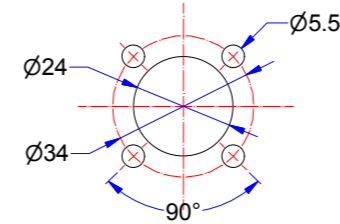

**ES1P 32 - 160 A**

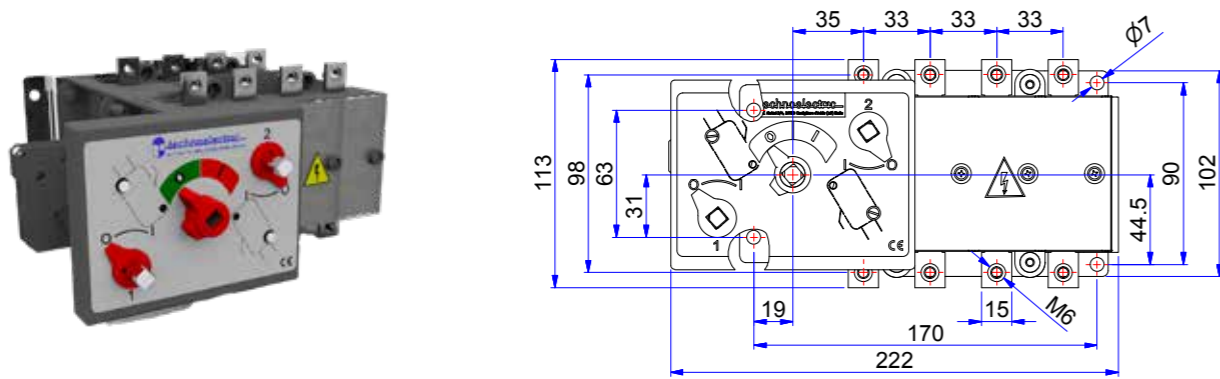

Foratura portella \_Door drilling

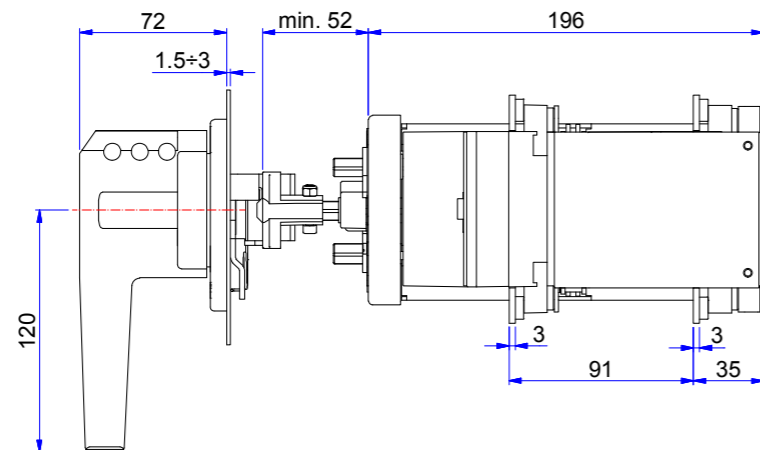
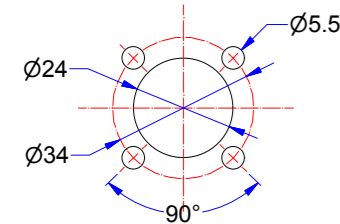

**ES3P 315 - 500 A**

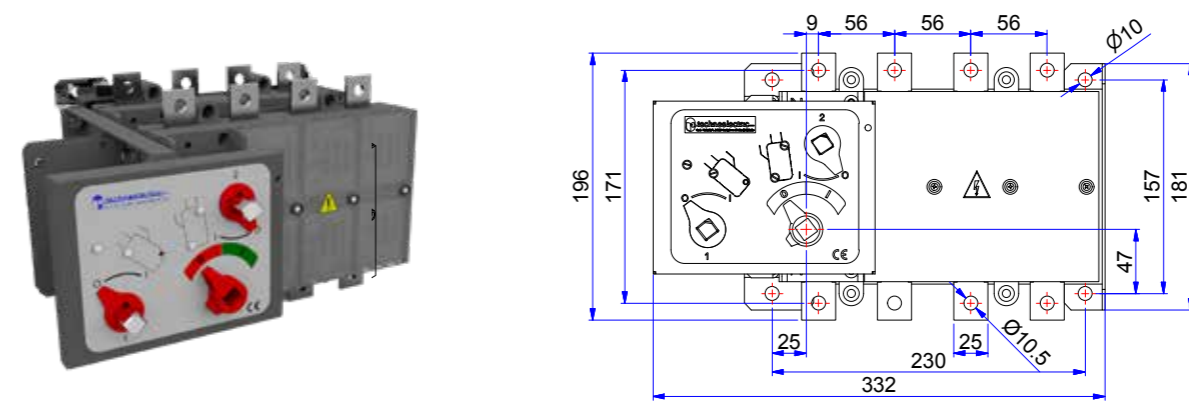

Foratura portella \_Door drilling

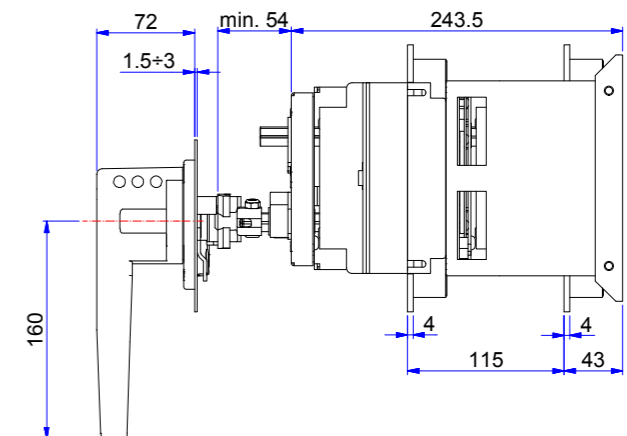
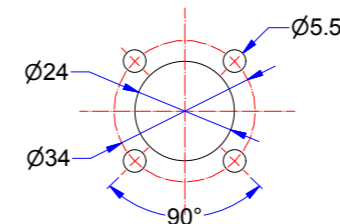

ES4P 630 - 800 A

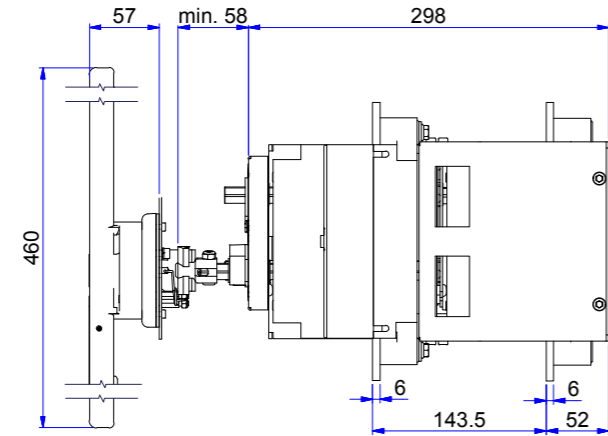
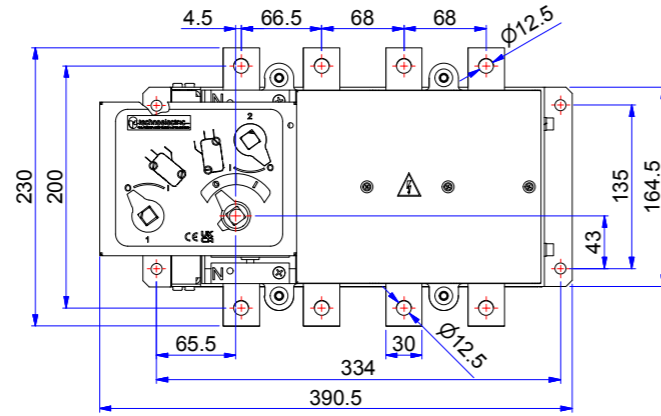

Foratura portella \_Door drilling

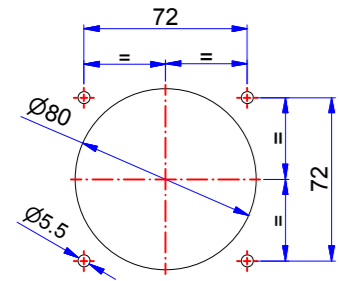

ES5P 800 - 1250 A 35 kA

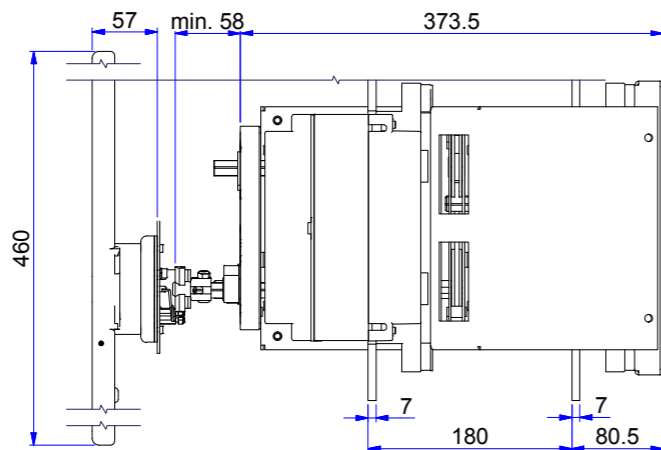
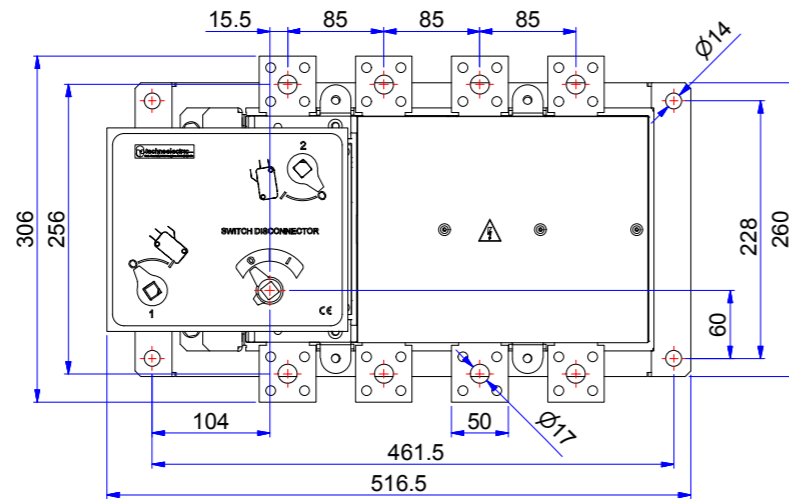

Foratura portella \_Door drilling

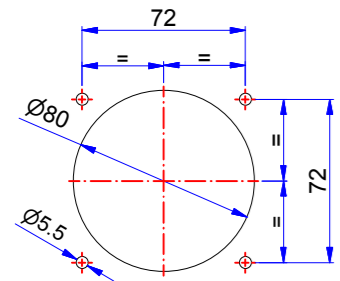

PBA

PBA visualcompact con dispositivo di apertura

GENERALITÀ

Gli interruttori della serie VISUALCOMPACT PBA 3 - 4 poli con comando manuale, sono corredati di un comando di apertura locale per mezzo di maniglia e a distanza tramite bobina a lancio di corrente alimentata dall'esterno.



\_PBA visualcompact with tripping device

GENERALITIES

The Visual Compact PBA are 3-4 poles switch disconnectors that can be remotely activated through an externally feeded tripping device.

Tipo _type	Corrente nominale _rated current	POLI _POLES	V aux. bobina _V aux coil					
			24 V c.c. \ DC	48 V c.c. \ DC	110 V c.c. \ DC	110 V c.a. \ AC	220 V c.a. \ AC	
<b>VC4P BA</b>	400 A	3	14002B	14002B1	14002B2	14002B3	14002B4	
		4	14012B	14012B1	14012B2	14012B3	14012B4	
	630A	3	14003B	14003B1	14003B2	14003B3	14003B4	
		4	14013B	14013B1	14013B2	14013B3	14013B4	
	800A	3	14004B	14004B1	14004B2	14004B3	14004B4	
		4	14014B	14014B1	14014B2	14014B3	14014B4	
	<b>VC5P BA 35kA</b>	800A	3	15000B	15000B1	15000B2	15000B3	15000B4
			4	15010B	15010B1	15010B2	15010B3	15010B4
1000A		3	15001B	15001B1	15001B2	15001B3	15001B4	
		4	15011B	15011B1	15011B2	15011B3	15011B4	
1250A		3	15002B	15002B1	15002B2	15002B3	15002B4	
		4	15012B	15012B1	15012B2	15012B3	15012B4	
<b>VC5P BA 50kA</b>		800A	3	15007B	15007B1	15007B2	15007B3	15007B4
			4	15017B	15017B1	15017B2	15017B3	15017B4
	1000A	3	15008B	15008B1	15008B2	15008B3	15008B4	
		4	15018B	15018B1	15018B2	15018B3	15018B4	
	1250A	3	15009B	15009B1	15009B2	15009B3	15009B4	
		4	15019B	15019B1	15019B2	15019B3	15019B4	
	1600A	3	15003B	15003B1	15003B2	15003B3	15003B4	
		4	15013B	15013B1	15013B2	15013B3	15013B4	
2000A	3	15004B	15004B1	15004B2	15004B3	15004B4		
	4	15014B	15014B1	15014B2	15014B3	15014B4		
<b>VC6P BA</b>	1600A	3	16000B	16000B1	16000B2	16000B3	16000B4	
		4	16010B	16010B1	16010B2	16010B3	16010B4	
	2000A	3	16001B	16001B1	16001B2	16001B3	16001B4	
		4	16011B	16011B1	16011B2	16011B3	16011B4	

**VC4P BA 400 ÷ 800 A**

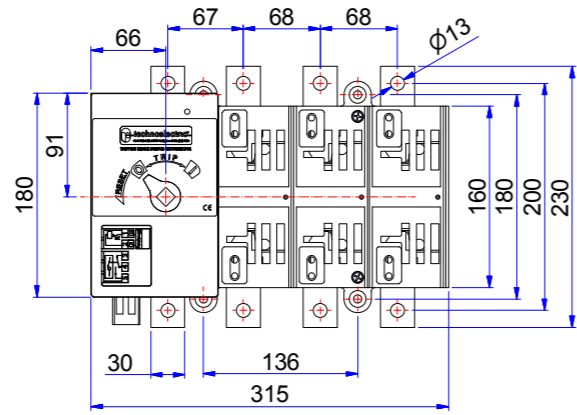

Foratura portella \_Door drilling

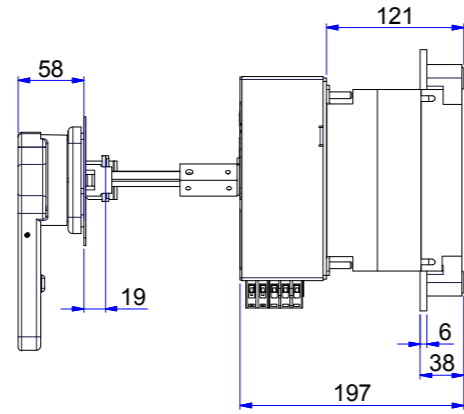
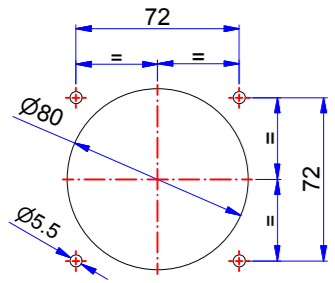

**VC5P BA 1600 ÷ 2000 A**

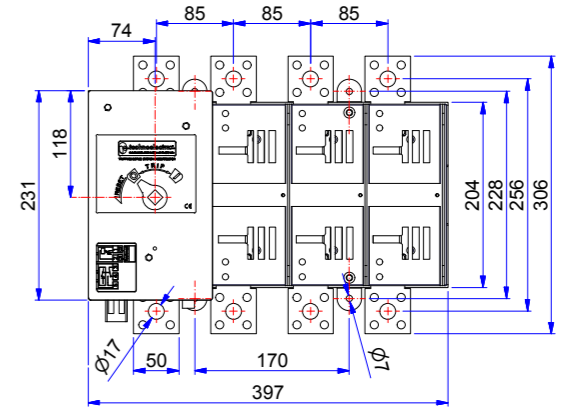

Foratura portella \_Door drilling

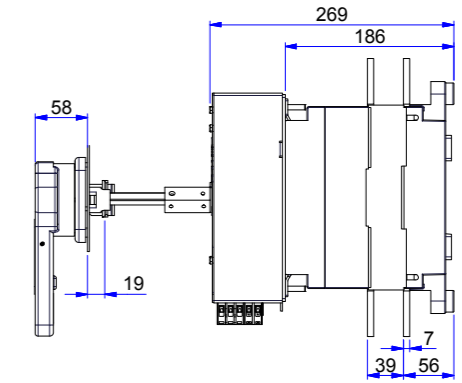
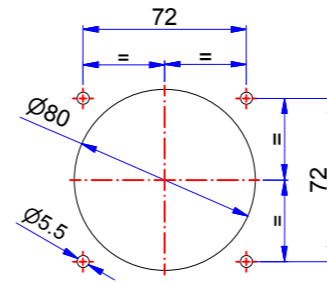

**VC5P BA 800 ÷ 1250 A**

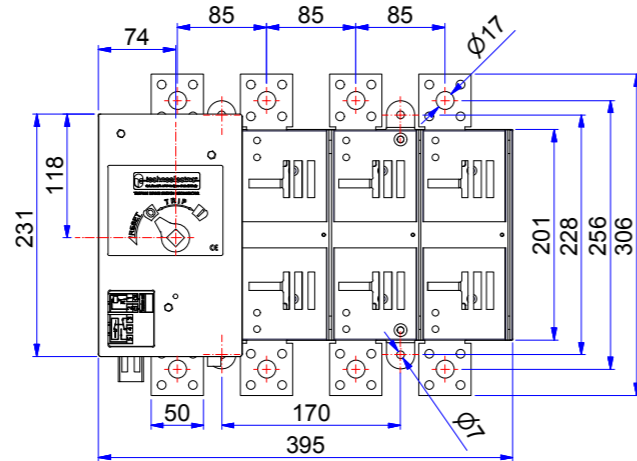

Foratura portella \_Door drilling

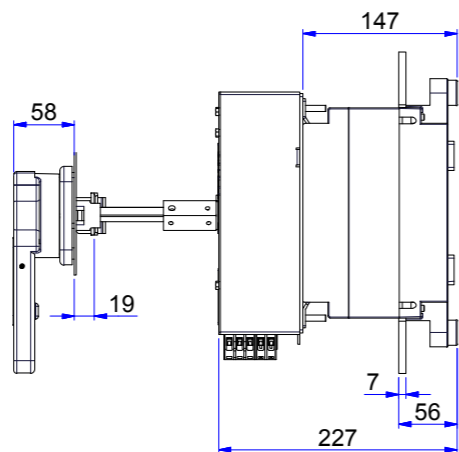
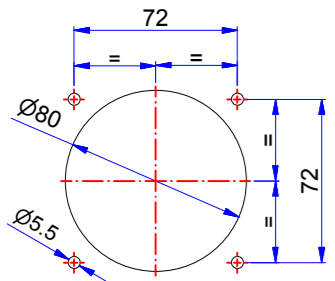

**VC6P BA 1600 A**

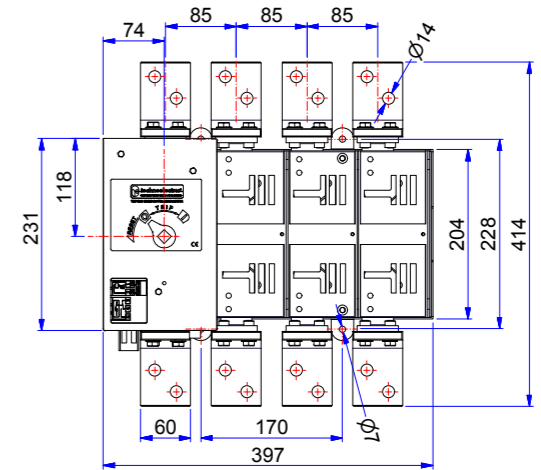

Foratura portella \_Door drilling

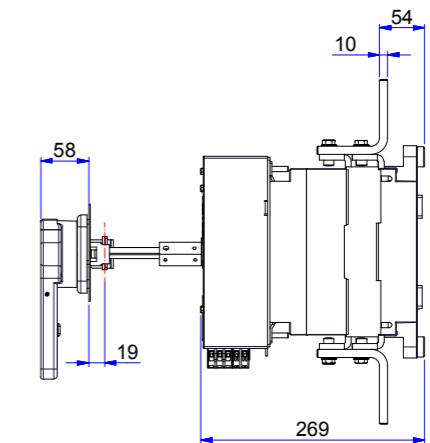
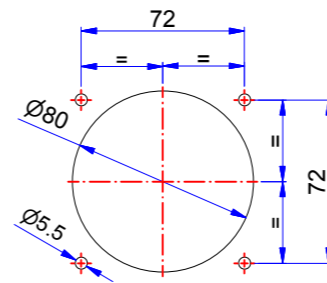

**VC6P BA 2000 A**

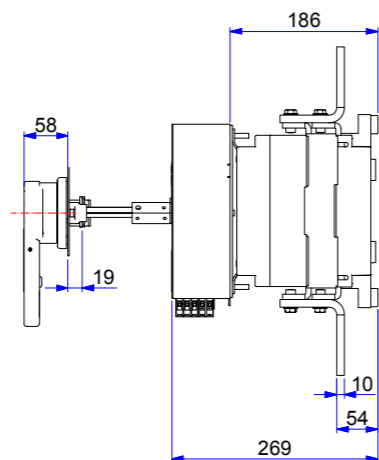
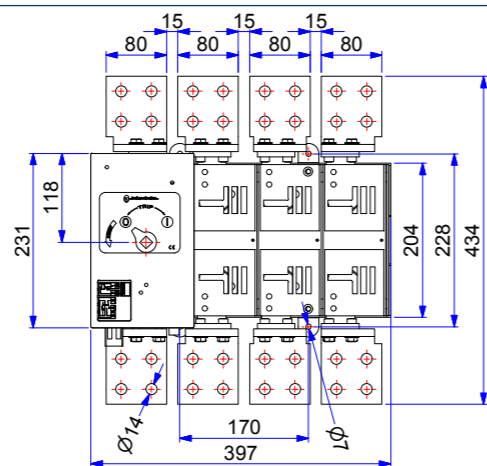

Foratura portella \_Door drilling

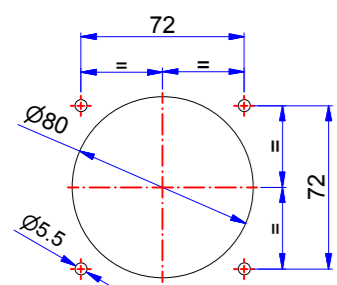

**SCHEMA MORSETTIERA BA \_terminal board diagram**

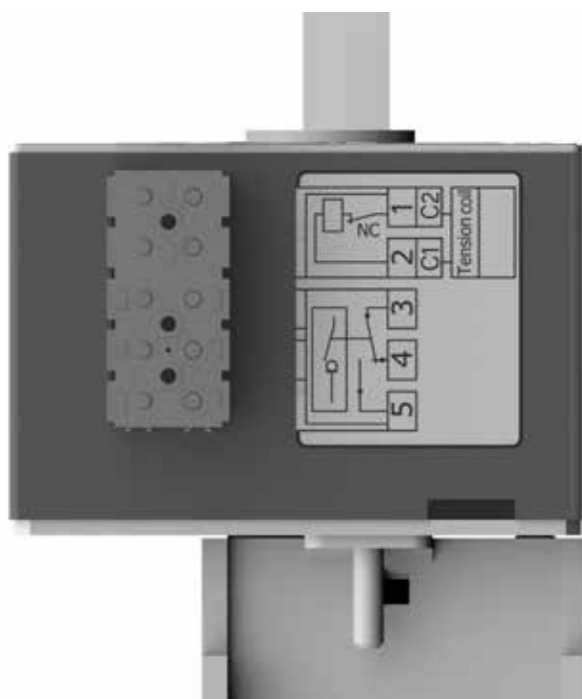

**VISUALCOMPACT VCP MS interruttori di manovra a comando motorizzato**

**GENERALITÀ**

La serie VISUALCOMPACT P MS consta di interruttori-sezionatori motorizzati a 3 - 4 poli con e senza porta fusibili. Assicura, attraverso un comando a distanza, manovre di apertura e chiusura sotto carico in sistemi e impianti di bassa tensione.

**CARATTERISTICHE GENERALI**

Le caratteristiche tecniche degli interruttori di manovra sezionatori impiegati nei VISUALCOMPACT P MS sono rispondenti a quanto riportato nei capitoli riguardanti la serie VISUALCOMPACT P.

Maniglia diretta per la manovra manuale di emergenza a corredo. Blocco meccanico di sicurezza lucchettabile che interdice la manovra elettrica e manuale.

Visualizzazione meccanica e luminosa (LED) della pos. 0,1 Segnalazione esterna della posizione tramite contatto AUX. (vedi morsettiera)

Tempo di manovra (0-1 o 1-0) 1,5 sec.

Alimentazione aux. 12/24VCC 110/220/380VCA

Temperatura ambiente di funzionamento - 20°C + 45°C con lucchetto in posizione 0.

**CONFORMITÀ ALLE NORME**

IEC 60947-1|IEC 60947-3|UNI EN 60947-1|UNI EN 60947-3|IEC 439-1|UNI EN 60439-1|IEC 204-1|UNI EN 60204-1 | EAC

**\_VISUALCOMPACT VCP MS motorized load break switches**

**GENERALITIES**

The Visual Compact MS Series are motorized Switch Disconnectors and Fuse switch disconnectors, that can be remotely operated.

**GENERAL CHARACTERISTICS**

The technical characteristics of the load break switches used in the VISUALCOMPACT P MS are correspondent to as shown in the chapter of VISUALCOMPACT P series.

Direct handle for manual emergency operations Emergency padlockable mechanical block of electrical and manual operations.

Position 0 and 1 are mechanically and electronically (LED) indicated

External Input position through auxiliary contacts (see terminal board diagram)

0-1 or 1-0 operating time 1,5 sec.

Voltages 12/24V DC, 110/220/380V AC

Working ambient temperature from - 20°C + 45°C padlock in 0 position.

**CONFORMITY TO STANDARDS**

IEC 60947-1|IEC 60947-3|UNI EN 60947-1|UNI EN 60947-3|IEC 439-1|UNI EN 60439-1|IEC 204-1|UNI EN 60204-1 | EAC



Schema morsettiera MS \_MS terminal block diagram

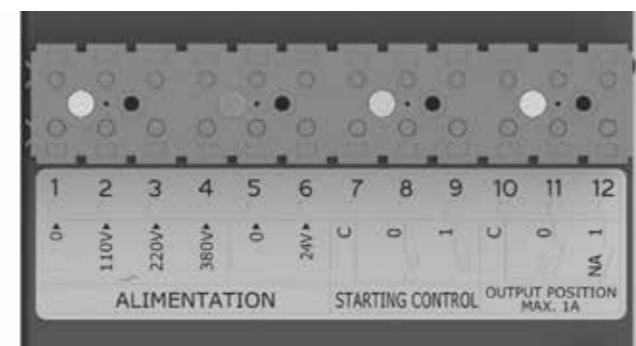

Tipo _type	Corrente nominale _rated current	POLI _POLES	Codice _Code	POLI _POLES	Codice _Code
<b>VC2P MS</b>	160 A	3	12001MS	4	12011MS
	200 A	3	12002MS	4	12012MS
	250 A	3	12003MS	4	12013MS
<b>VC3P MS</b>	315 A	3	13001MS	4	13011MS
	400 A	3	13002MS	4	13012MS
<b>VC4P MS</b>	630 A	3	14003MS	4	14013MS
	800 A	3	14004MS	4	14014MS
<b>VC5P MS 35kA</b>	800 A	3	15000MS	4	15010MS
	1000 A	3	15001MS	4	15011MS
	1250 A	3	15002MS	4	15012MS
<b>VC5P MS 50kA</b>	800 A	3	15007MS	4	15017MS
	1000 A	3	15008MS	4	15018MS
	1250 A	3	15009MS	4	15019MS
<b>VC6P MS</b>	1600 A	3	15003MS	4	15013MS
	2000 A	3	15004MS	4	15014MS
	2500 A	3	15005MS	4	15015MS
<b>VC6P MS</b>	3150 A	3	15006MS	4	15016MS
	1600 A	3	16000MS	4	16010MS
	2000 A	3	16001MS	4	16011MS
<b>VC6P MS</b>	2500 A	3	16002MS	4	16012MS
	3150 A	3	16003MS	4	16013MS



**VC2P MS 160 - 250A**

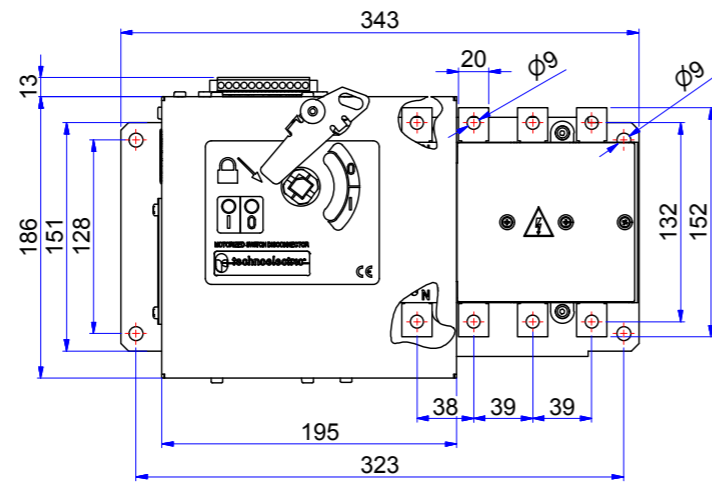
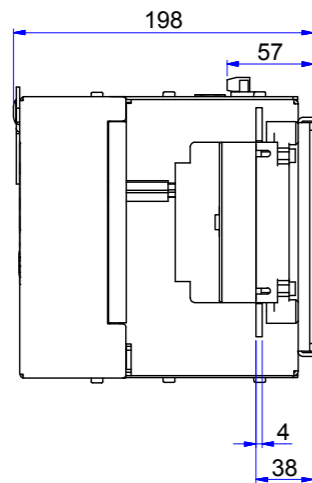

**VC4P MS 630A÷800A**

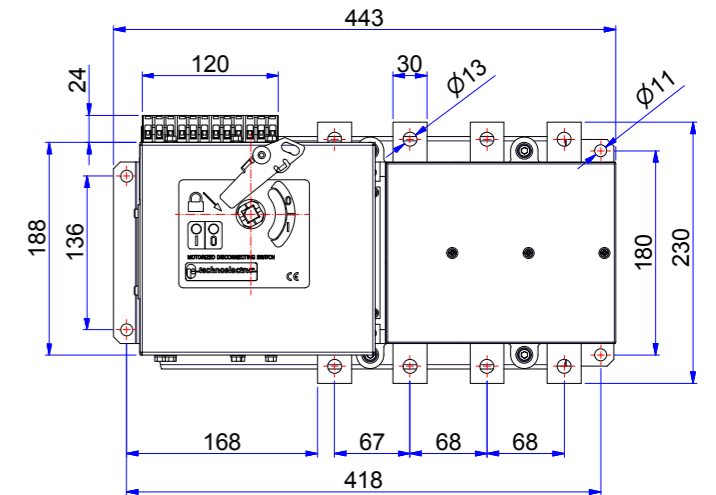
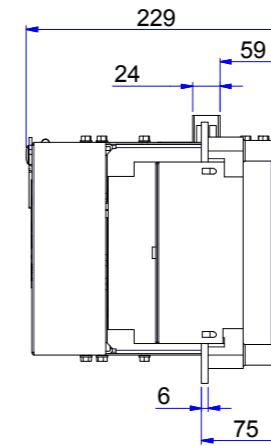

**VC3P MS 315 - 400 A**

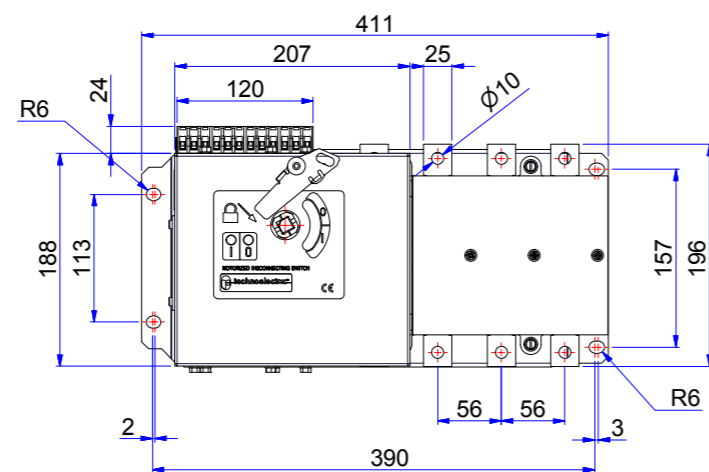
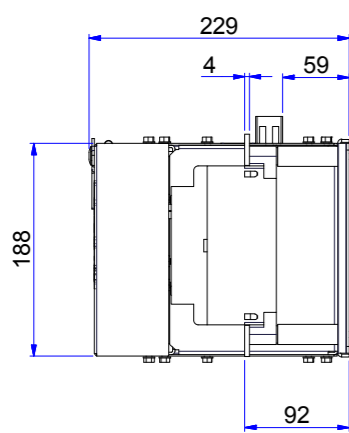

**VC5P MS 800A÷1250A**

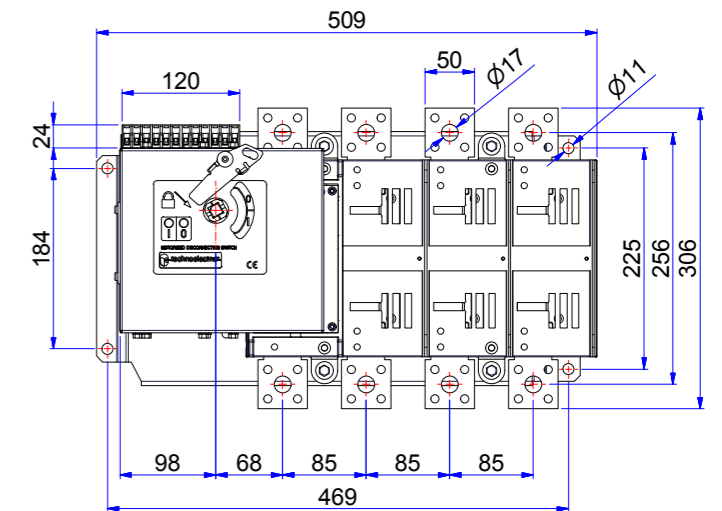
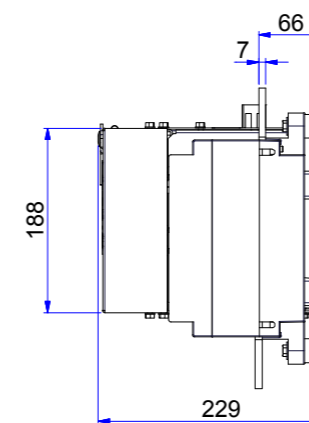

**VC5P MS 1600A÷2000A**

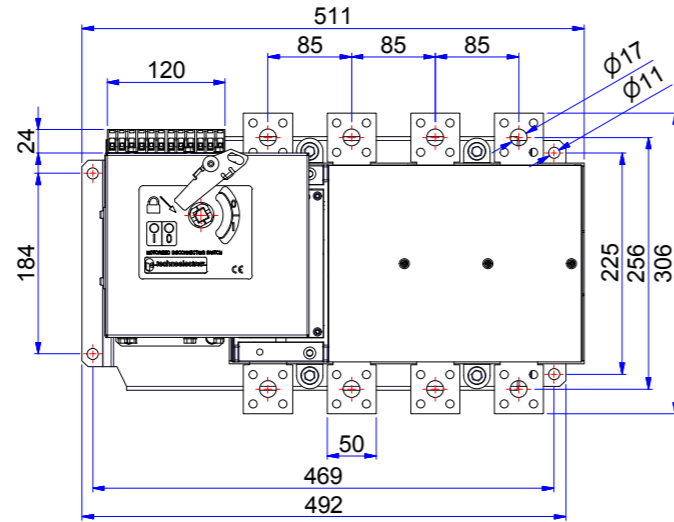
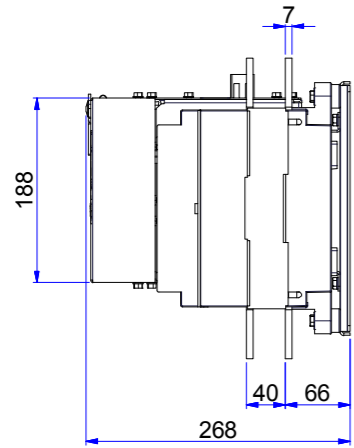

**VC6P MS 1600A FN**

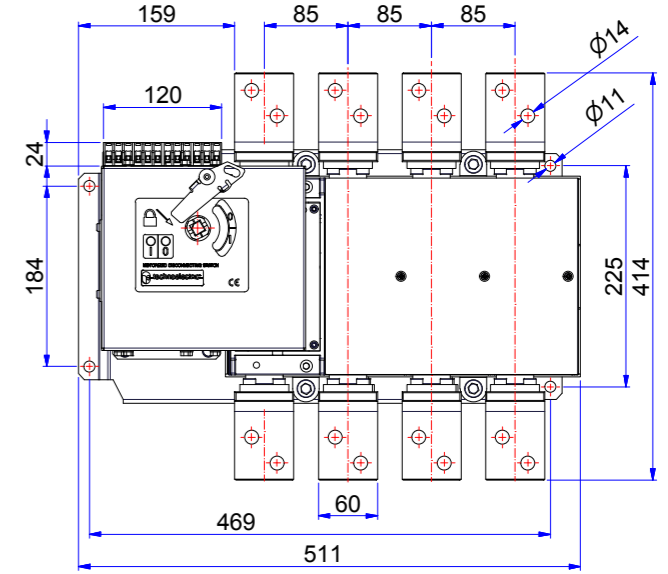
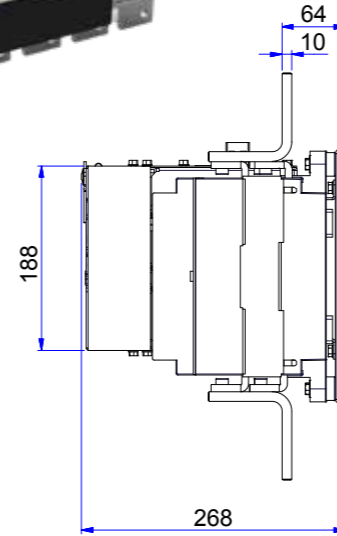

**VC5P MS 2500A÷3150A**

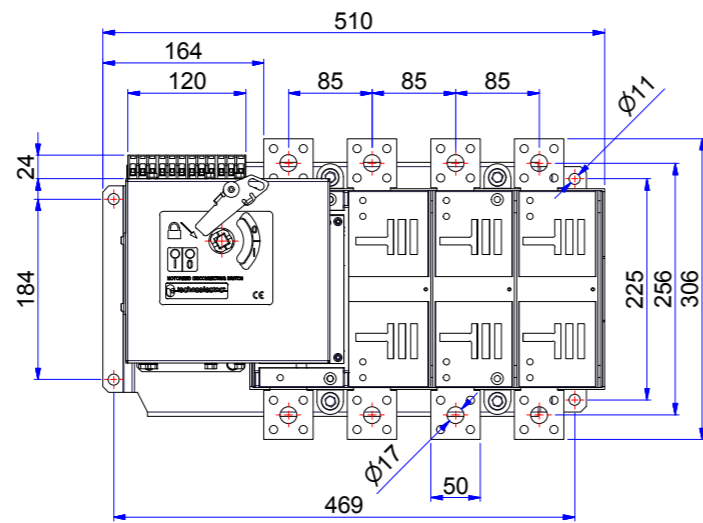
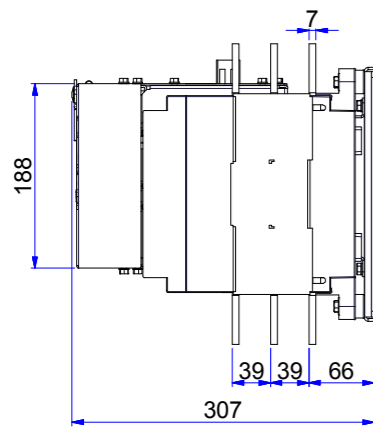

**VC6P MS 1600A NEUTRO \_neutral 1250A**

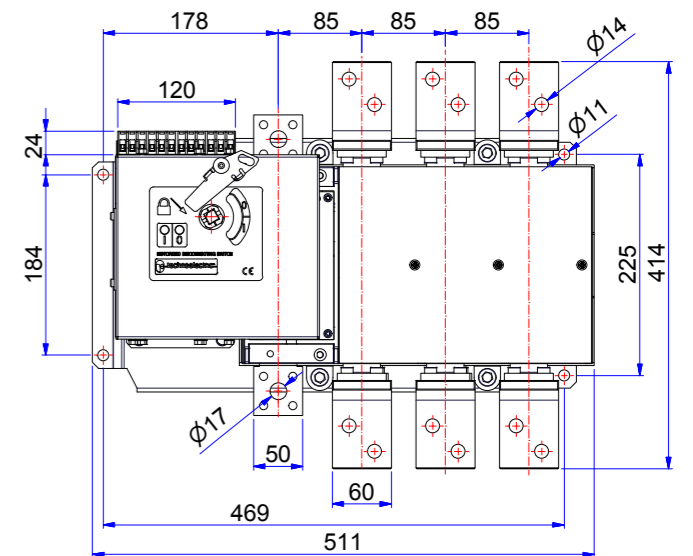
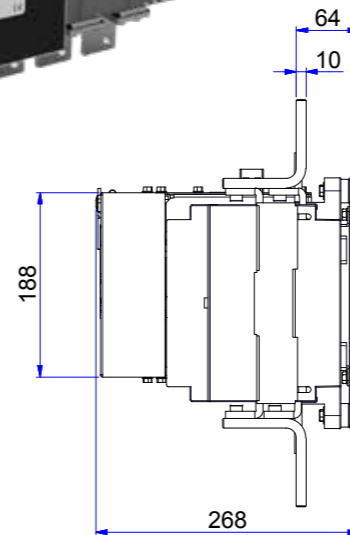

**VC6P MS 2000A FN**

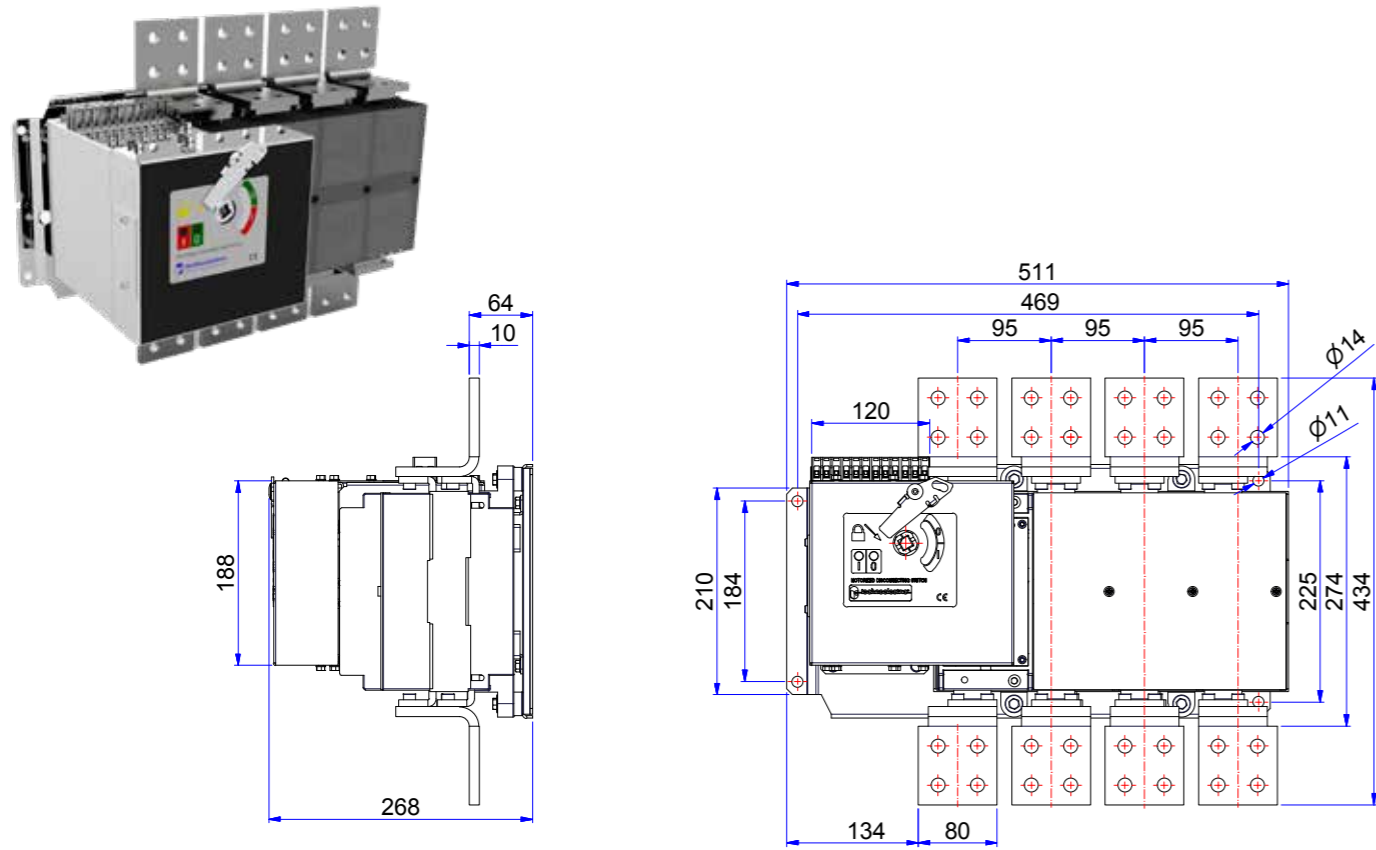

**VC6P MS 2500A FN**

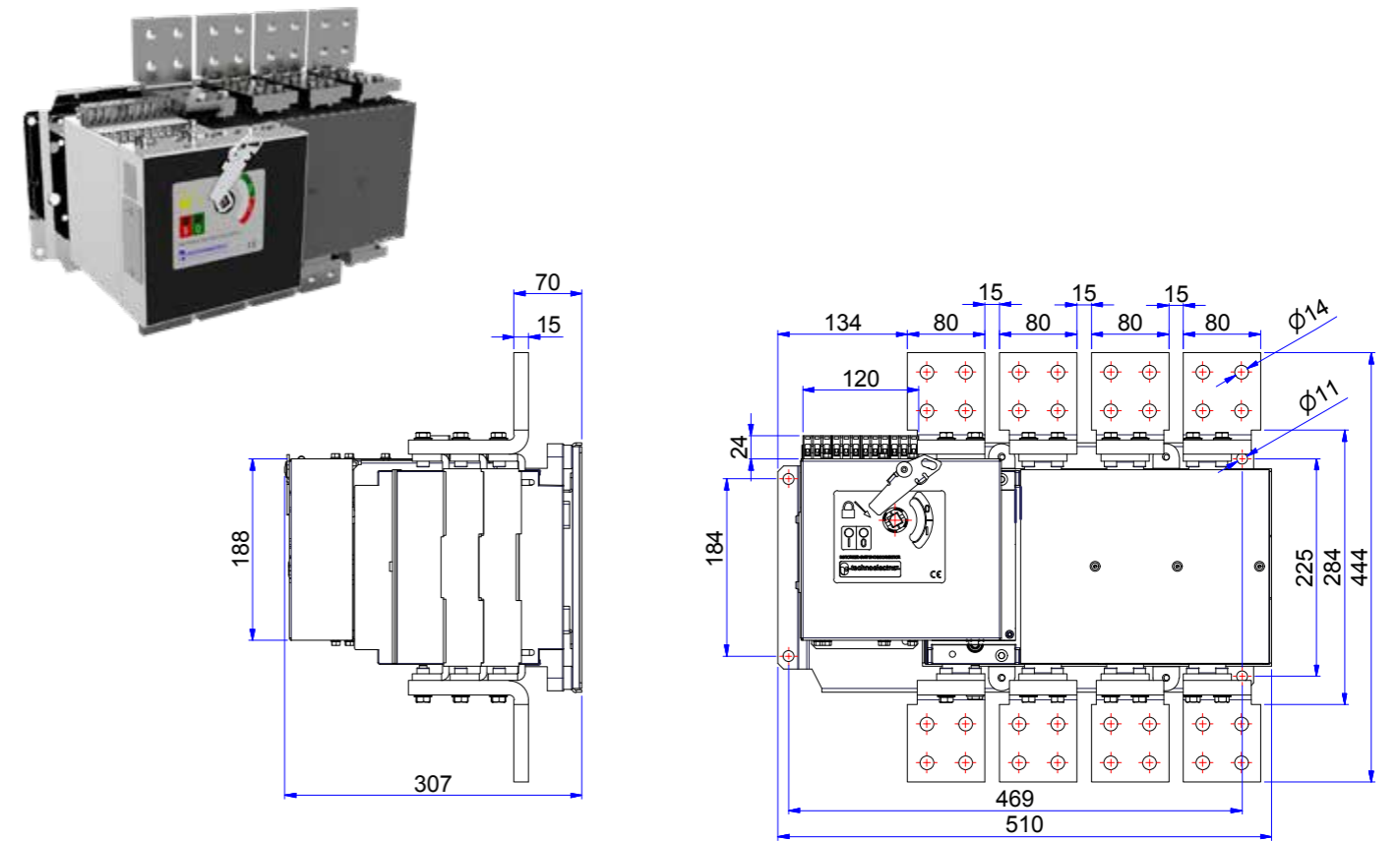

**VC6P MS 2000A NEUTRO \_neutral 1250A**

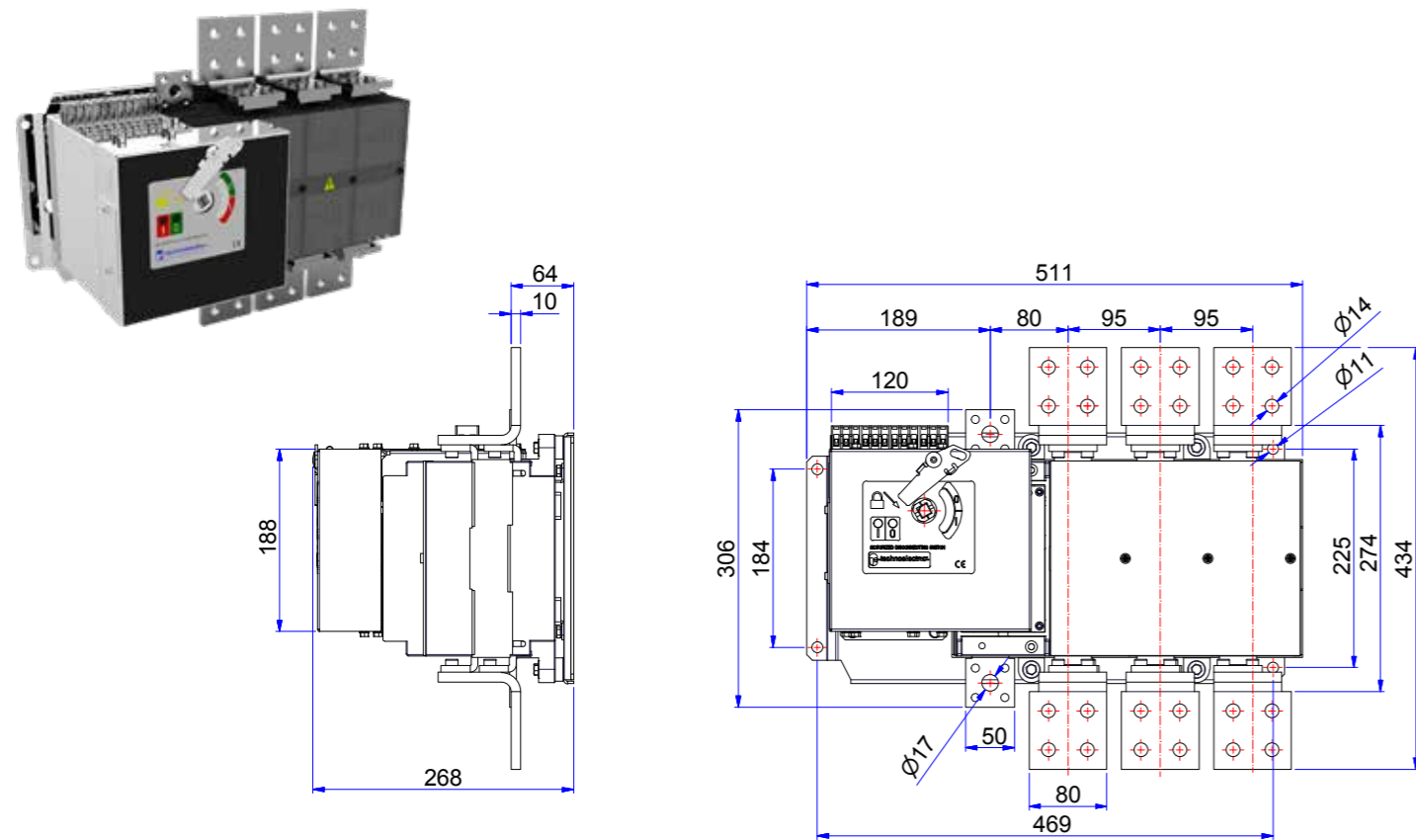

**VC6P MS 2500A NEUTRO \_neutral 1250A**

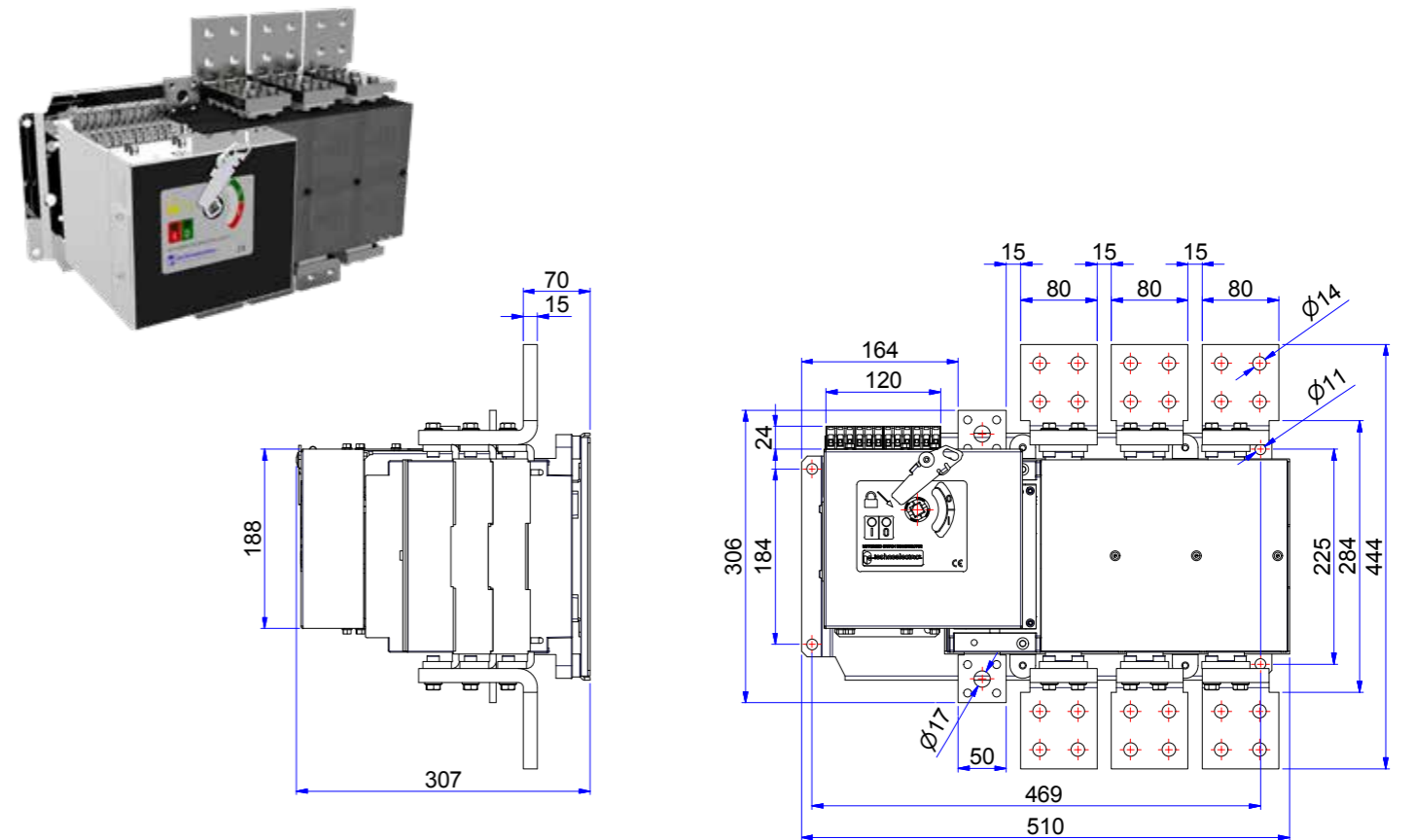

**VC6P MS 3150A**

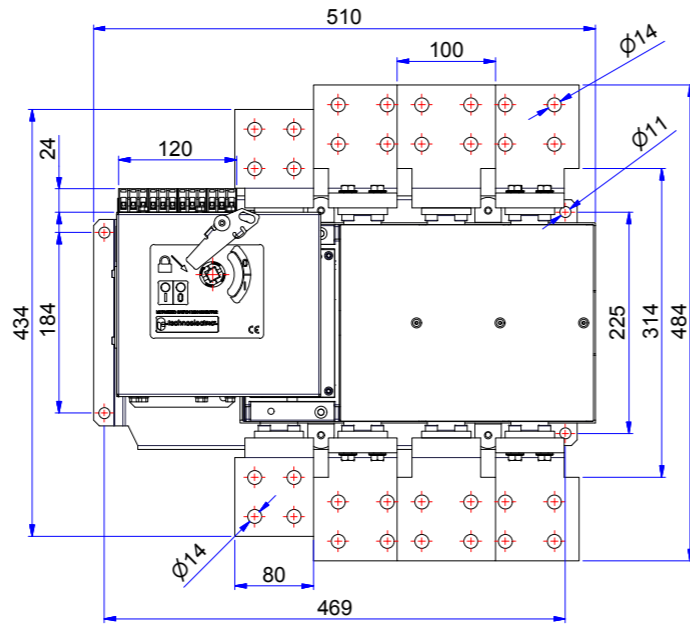
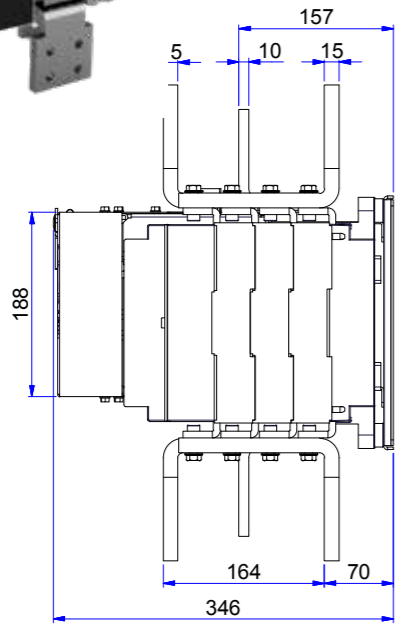

**MANIGLIA BLOCCO PORTA NERA**  
**\_black door interlock handle**

Tipo_type	Poli_poles	VC1P	VC2P	VC3P	VC4P	VC5P	VC5P 50kA	VC6P
Codice_code	3   4	18001	18001	18003	18003	18005   18007	18830   18844	18830   18844
Codice_code	6   8	18003	18003	18005	18830	18870	18870	18870

**18001**

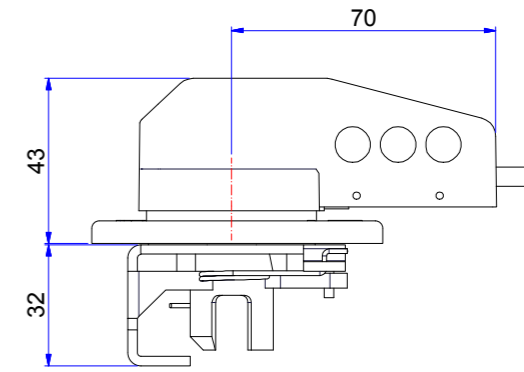

Foratura portella \_Door drilling

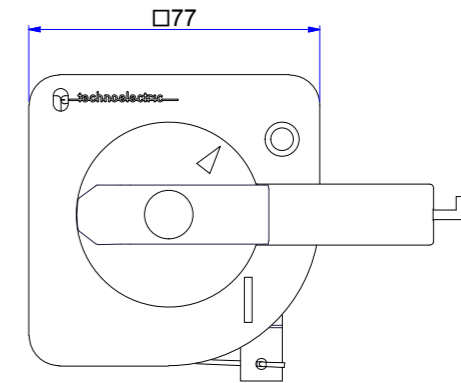
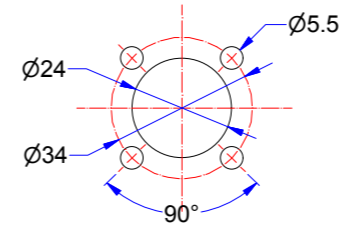

**18003**

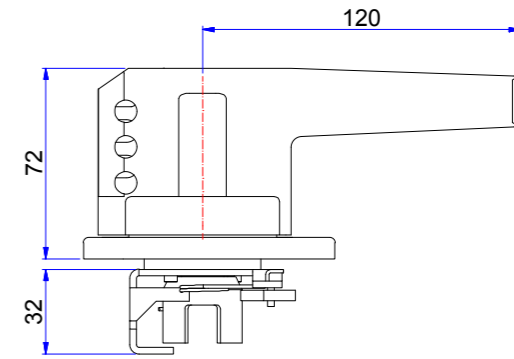

Foratura portella \_Door drilling

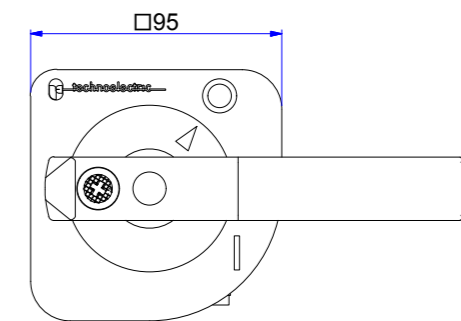
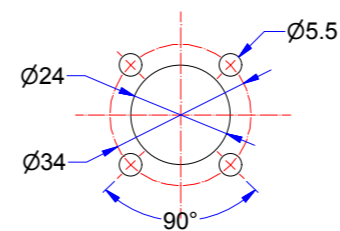



18005

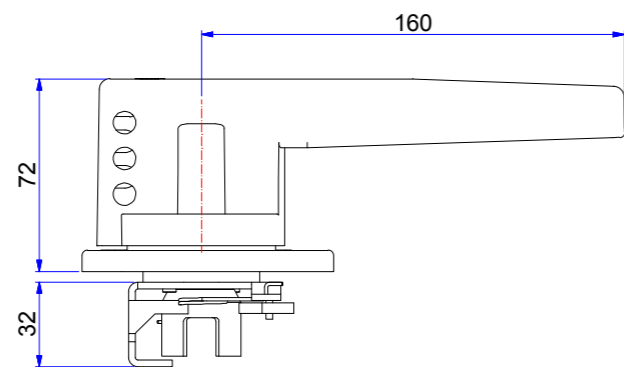

Foratura portella \_Door drilling

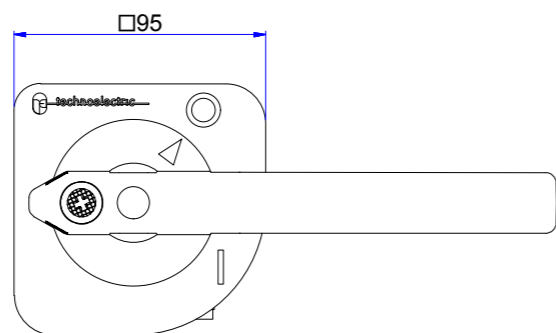
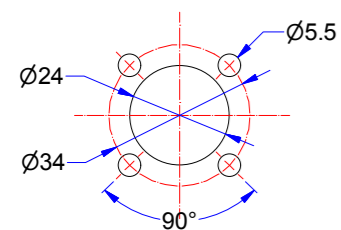

18830 - 18870

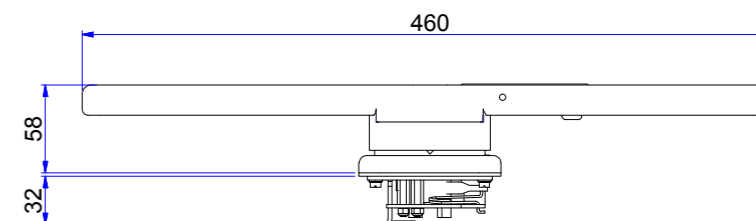

Foratura portella \_Door drilling

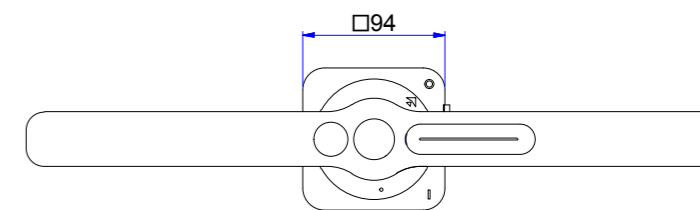
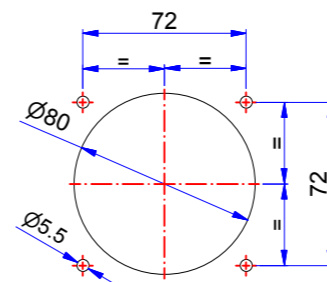

18007

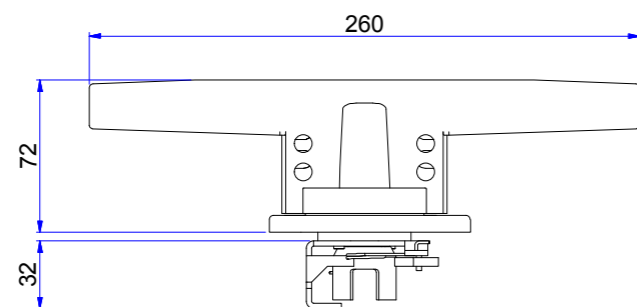

Foratura portella \_Door drilling

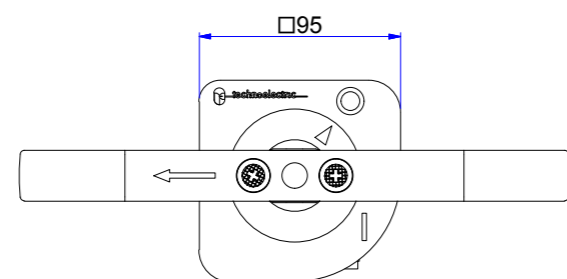
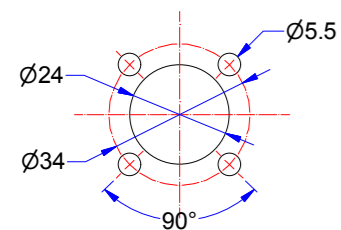

18844

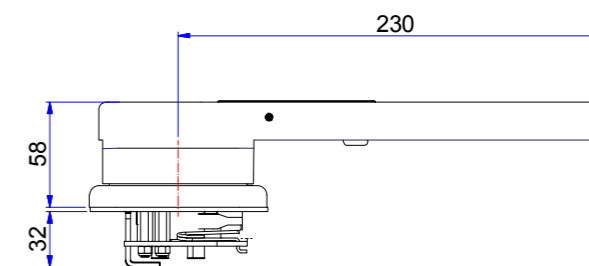

Foratura portella \_Door drilling

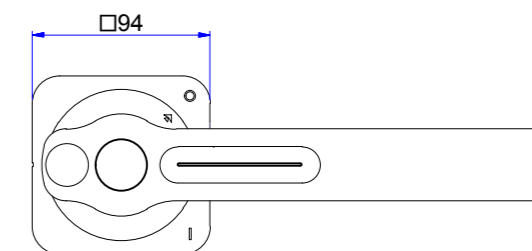
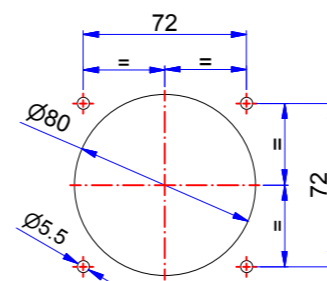

**MANIGLIA BLOCCO PORTA D'EMERGENZA**

**\_red\yellow door interlock handle**

Tipo_type	Poli_poles	VC1P	VC2P	VC3P	VC4P	VC5P	VC5P 50kA	VC6P
Codice_code	3   4	18002	18002	18004	18004	18006   18008	18831   18847	18831   18847
Codice_code	6   8	18004	1804	18006	18831	18871	18871	18871

**18002**

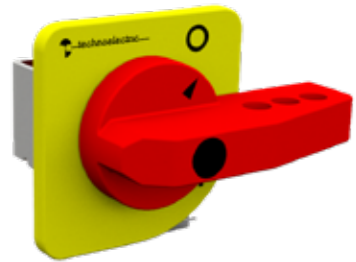

Foratura portella \_Door drilling

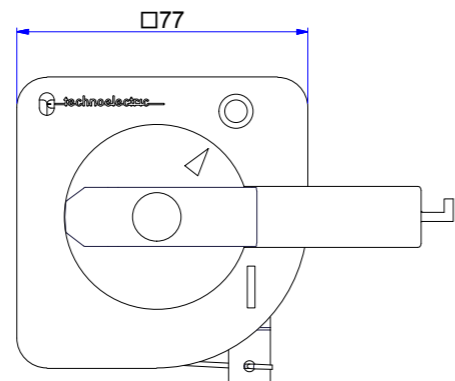
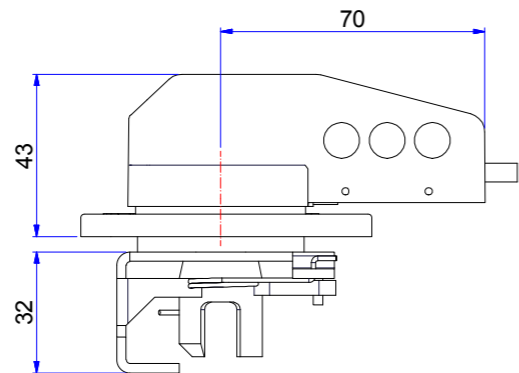
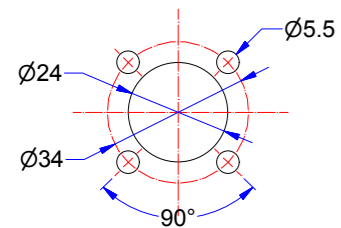

**18006**

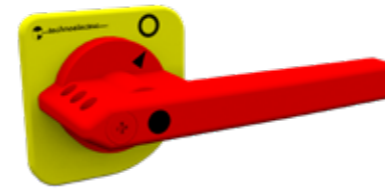

Foratura portella \_Door drilling

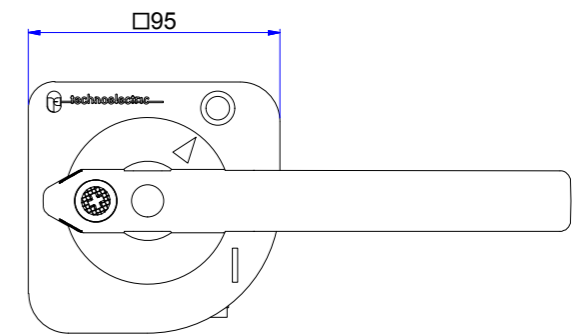
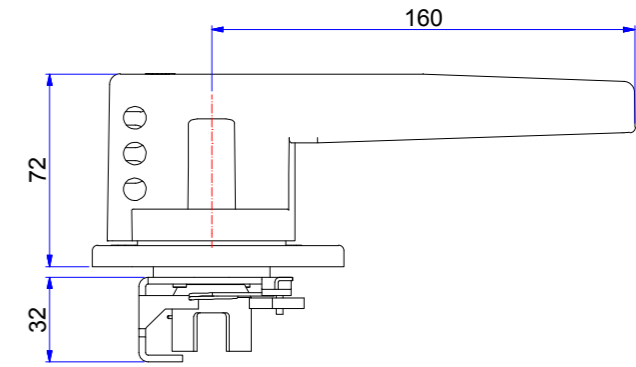
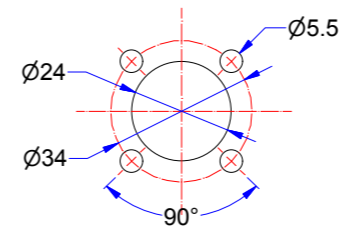

**18004**



Foratura portella \_Door drilling

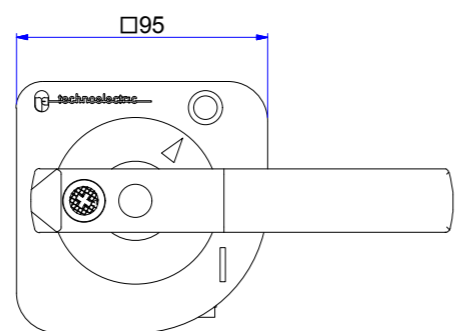
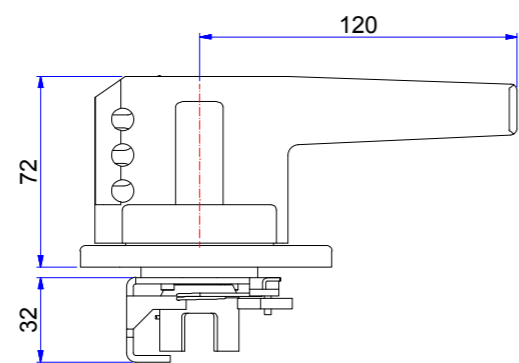
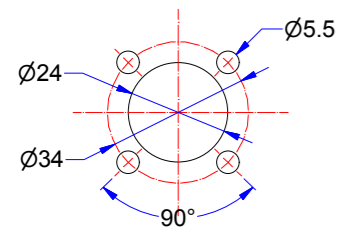

**18008**



Foratura portella \_Door drilling

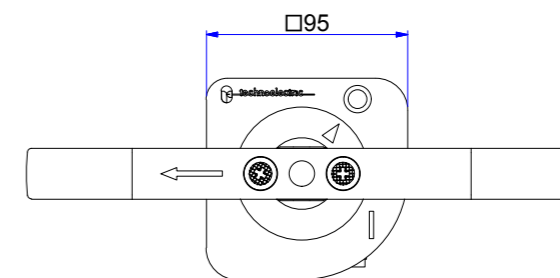
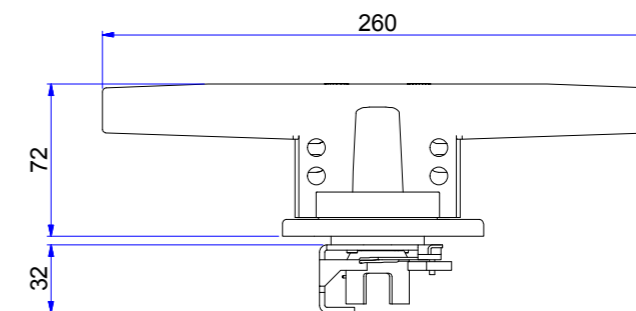
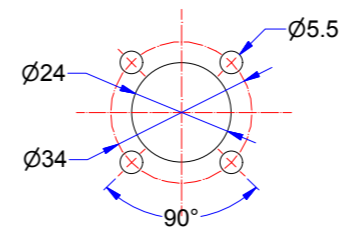

18831 - 18871

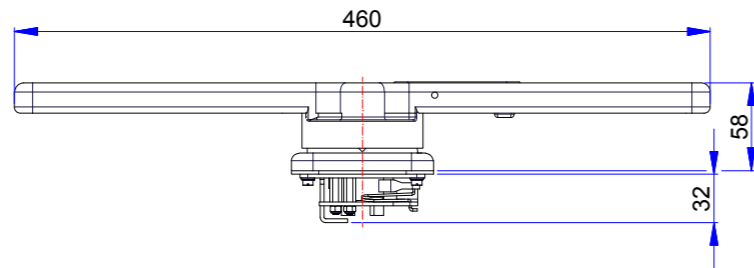

Foratura portella \_Door drilling

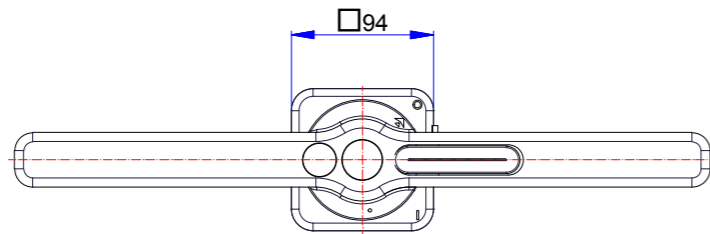
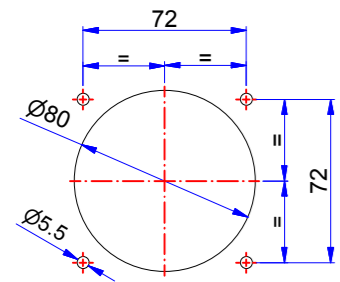

18847

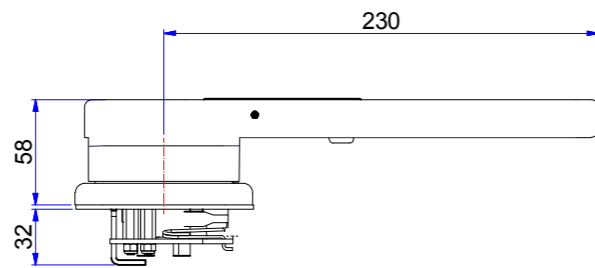

Foratura portella \_Door drilling

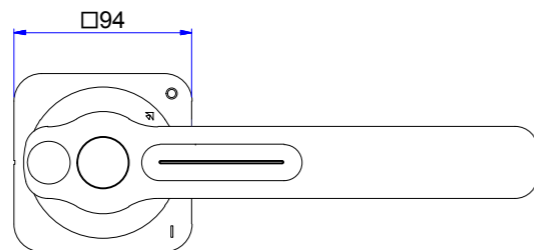
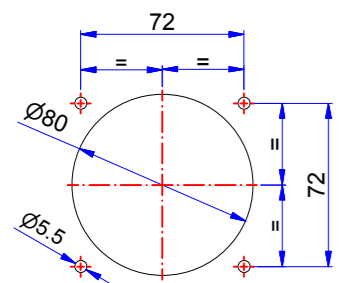

ALBERO COMANDO  
\_shaft



200 mm

Tipo_type	VC1P	VC2P	VC3P	VC4P	VC5P	VC5P 50kA	VC6P
Codice_code	18201	18201	18207	18207	18207	18207	18207

300 mm

Tipo_type	VC1P	VC2P	VC3P	VC4P	VC5P	VC5P 50kA	VC6P
Codice_code	18202	18202	18208	18208	18208	18208	18208

400 mm

Tipo_type	VC1P	VC2P	VC3P	VC4P	VC5P	VC5P 50kA	VC6P
Codice_code	18203	18203	18209	18209	18209	18209	18209

MANIGLIA DIRETTA  
\_direct handle

Tipo_type	VC1P	VC2P	VC3P	VC4P	VC5P	VC5P 50kA	VC6P
Codice_code	18020	18021	18320	18022	18023	18840 (460 mm) / 18852 (230 mm)	18840 (460 mm) / 18852 (230 mm)

Fornita completa di schermo protezione contatti principali \_Supplied with main contacts cover shield

18020 - 18021

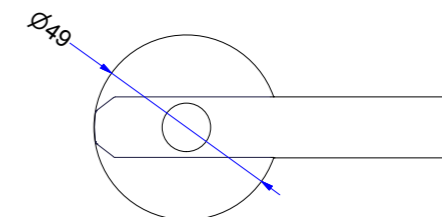
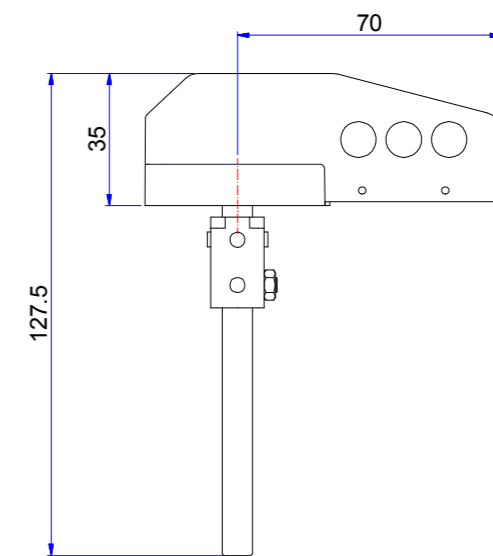

18320 - 18022 - 18023

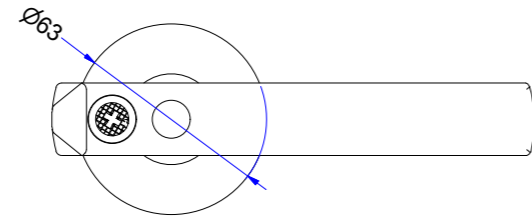
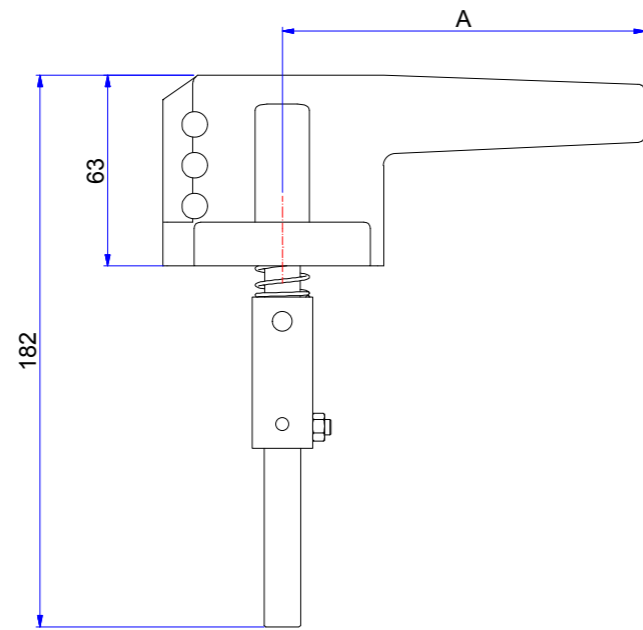

Tipo_type	A
18320	120
18022	120
18023	160

18851 - 18852

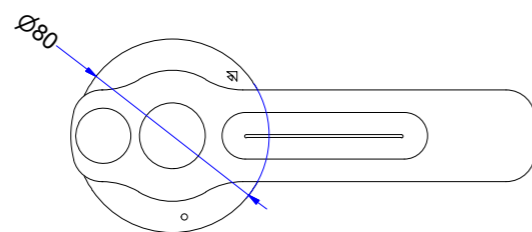
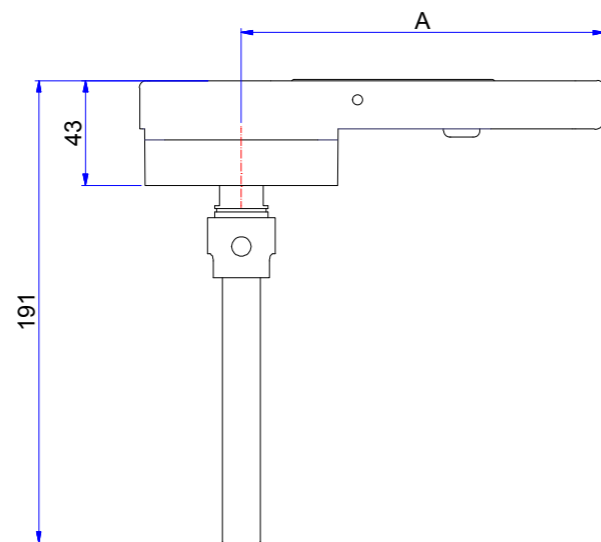
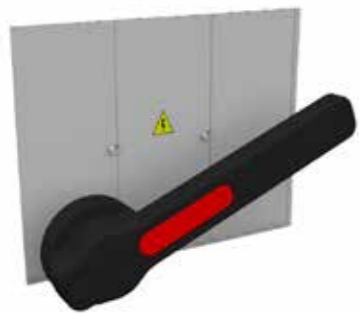

Tipo_type	A
18851	150
18852	230

18840

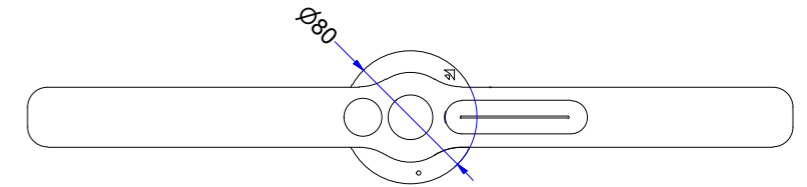
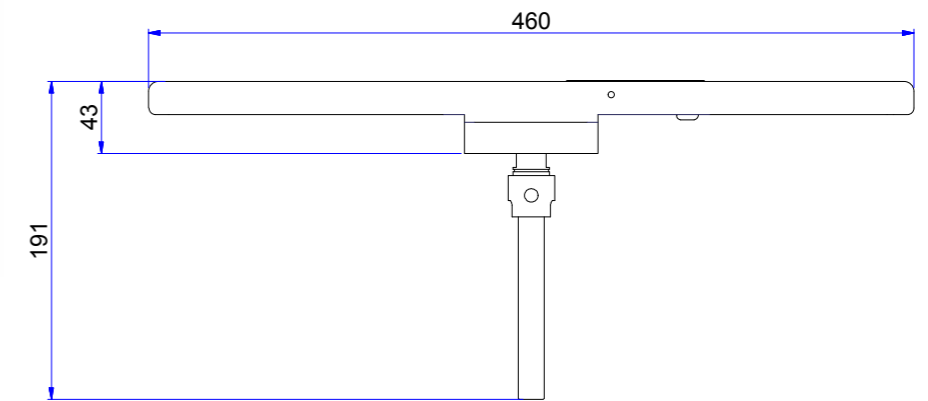
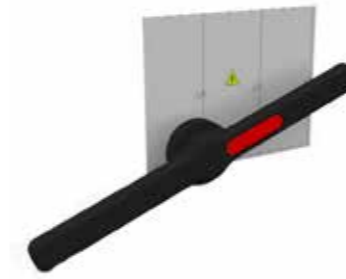

MANIGLIA DIRETTA  
\_direct handle

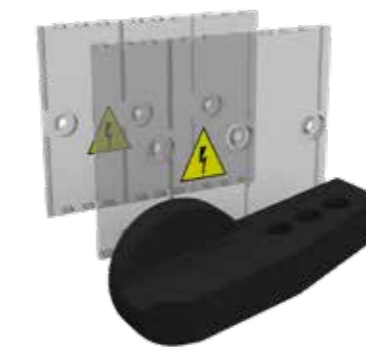

EOP

Tipo_type	EO1P	EO2P	EO3P	EO4P	EO5P
Codice_code	18588	18589	18590	18591	18853

Fornita completa di due schermi copricontatti principali per interruttori di tipo P  
Versione lucchettabile fornibile a richiesta

\_Supplied with two cover main contacts over shields.  
Padlockable version on request

BLOCCO LUCCHETTO PER MANIGLIA DIRETTA  
\_padlock for direct handle

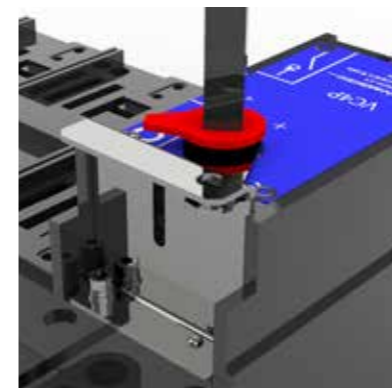

Tipo_type	VC1P	VC2P	VC3P	VC4P	VC5P
Codice_code	18240	18241	18242	18243	18244

Tipo_type	VC5P 50 kA				VC6P			
	1600A	2000A	2500A	3150A	1600A	2000A	2500A	3150A
Codice_code	18245	18245	18246	18246	18245	18245	18246	18247



**MANIGLIA DIRETTA PER VCP MS**  
**\_direct handle for VCP MS**

Tipo_type	VC2P MS	VC3P MS	VC4P MS	VC5P MS	VC6P MS
Codice_code	18802	18803	18803	18803	18803

**18802**

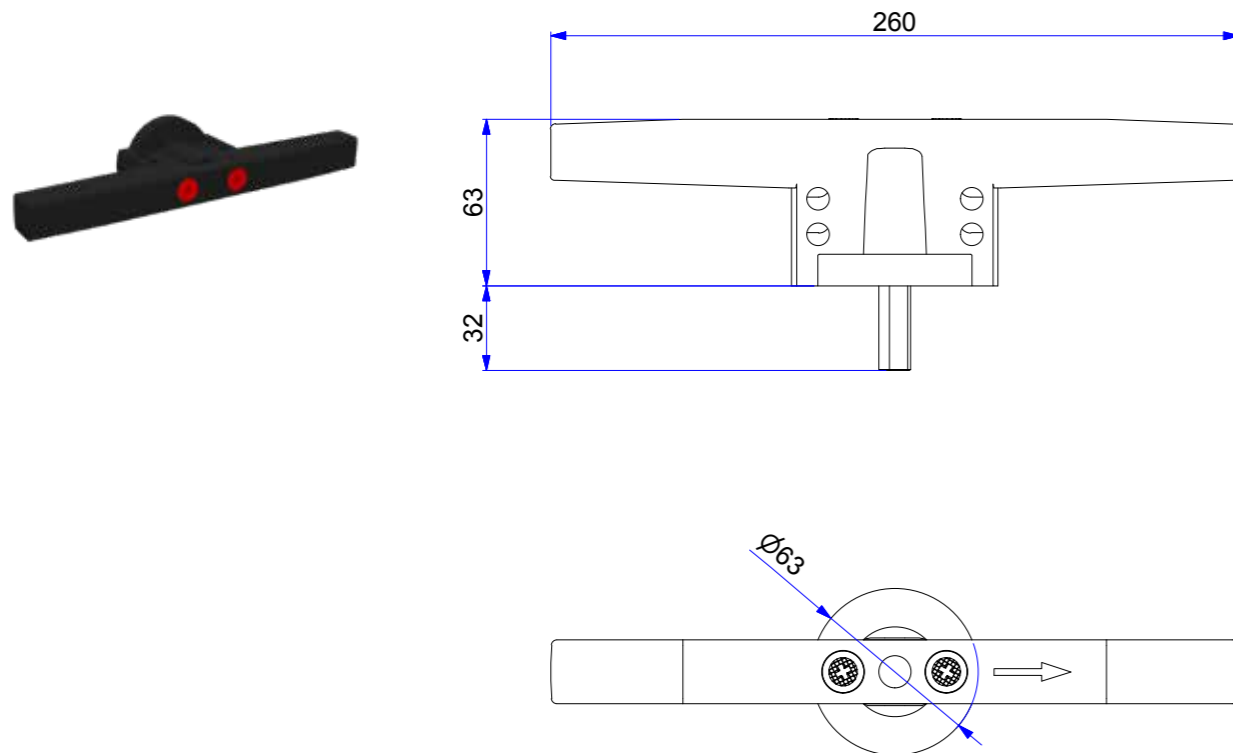

**18803**

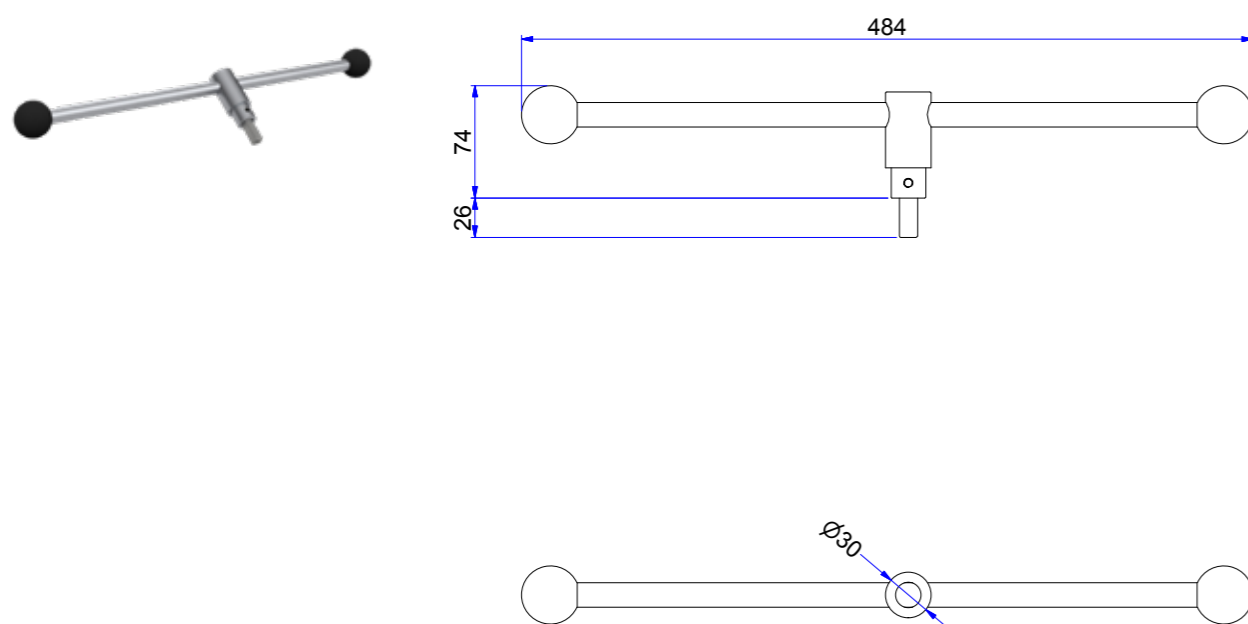

**MANIGLIA BLOCCO PORTA CON BLOCCO CHIAVE**  
**\_door interlock handle with key lock**

Tipo_type	VC1P	VC2P	VC3P	VC4P	VC5P	VC5P 50kA	VC6P
Codice_code	18100	18100	18100	18100	18102  18104	a richiesta_on request	a richiesta_on request

**18100**

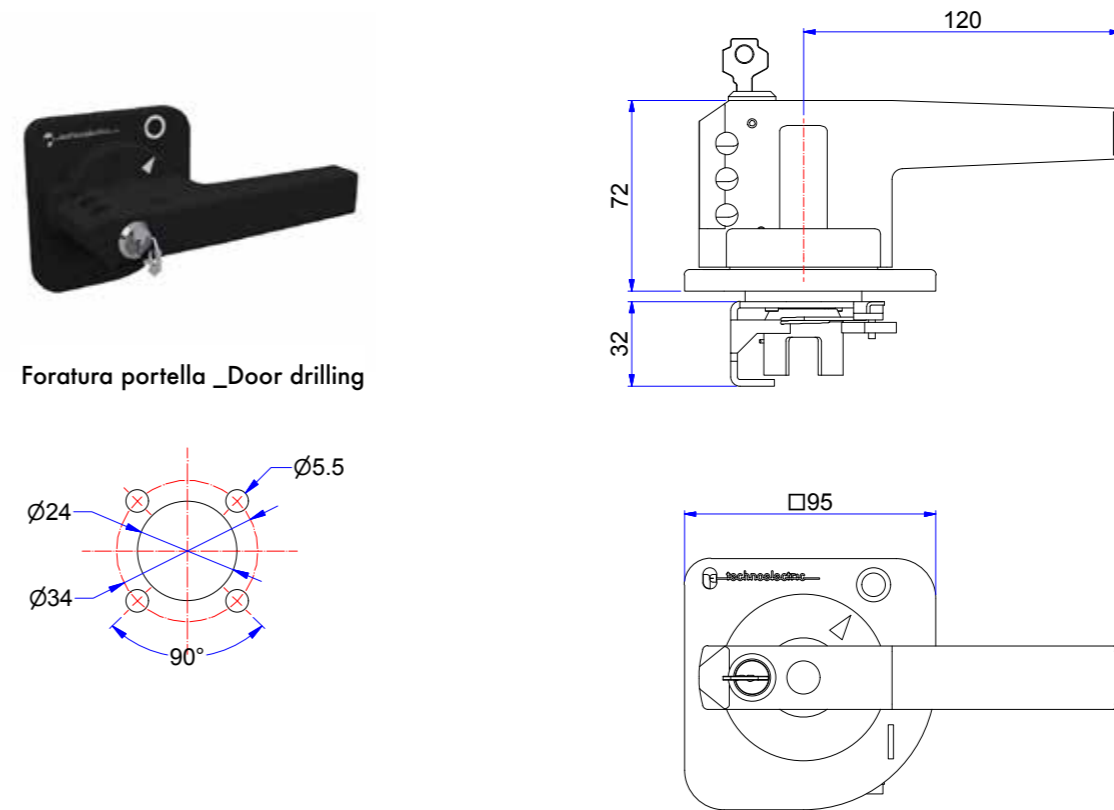

Foratura portella \_Door drilling

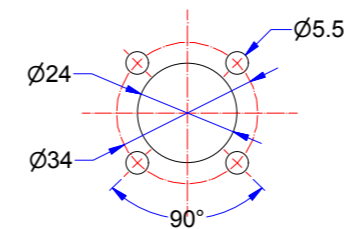

**18102**

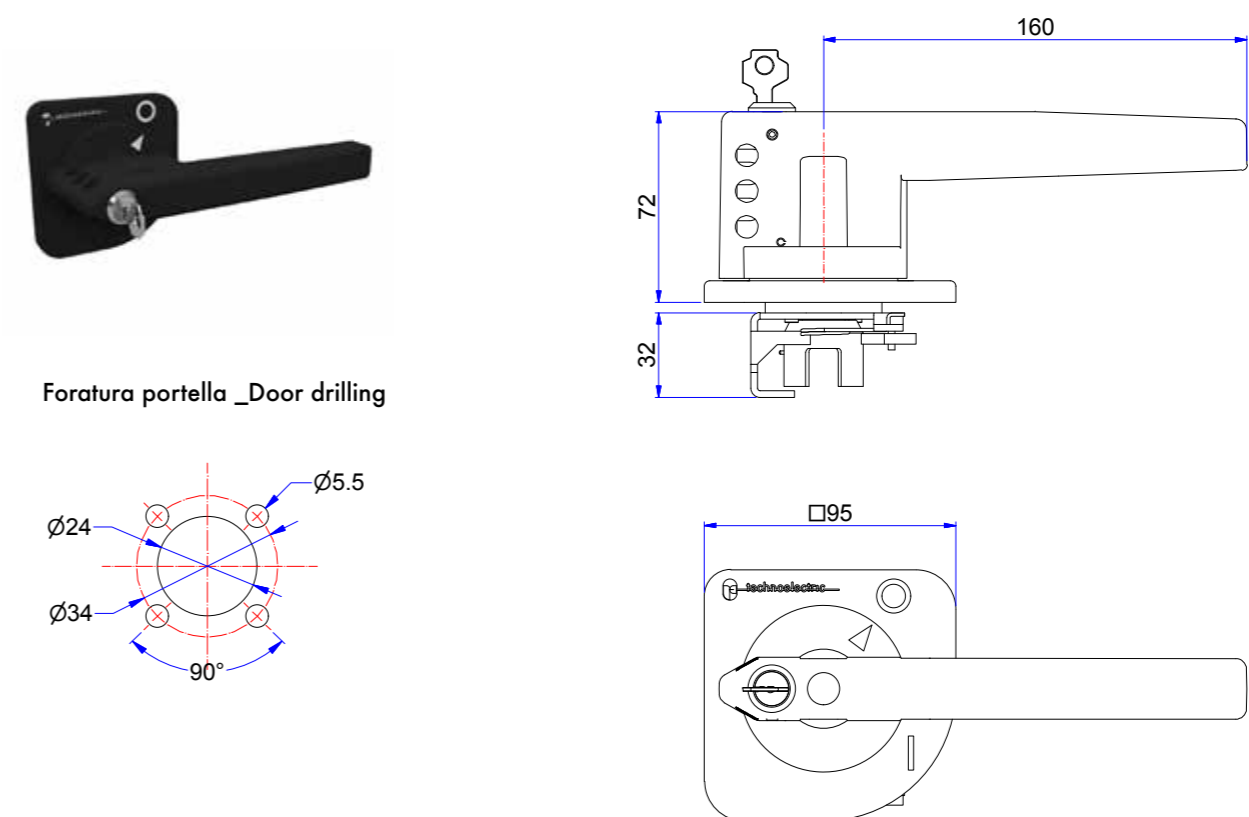

Foratura portella \_Door drilling

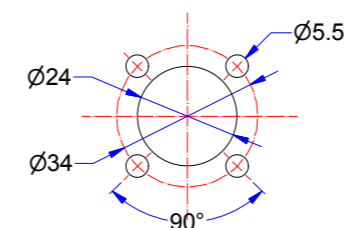

18104

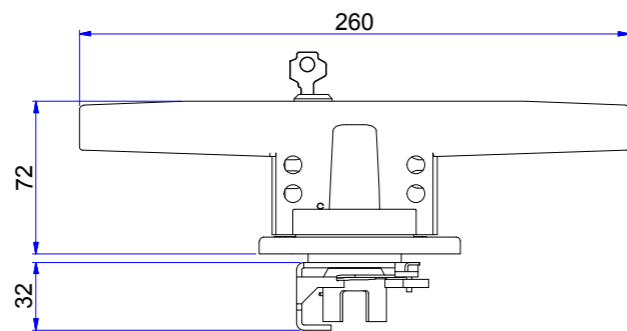

Foratura portella \_Door drilling

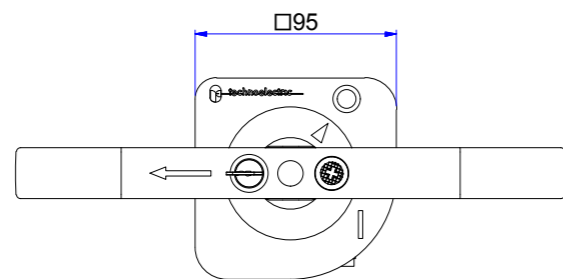
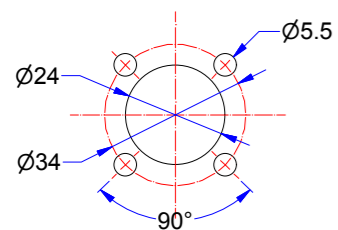

**MANIGLIA BLOCCO PORTA NERA  
CON DISPOSITIVO DI SBLOCCO CON ATTREZZO SPECIALE  
\_black door interlock handle with defeater mechanism (special tool)**

Tipo_type	VC1P	VC2P	VC3P	VC4P	VC5P	VC5P 50kA	VC6P
Codice_code	18220	18220	18222	18222	18224	18832 18850	18832 18850

18220

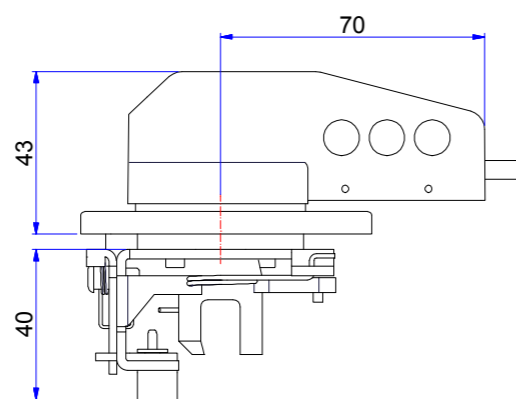

Foratura portella \_Door drilling

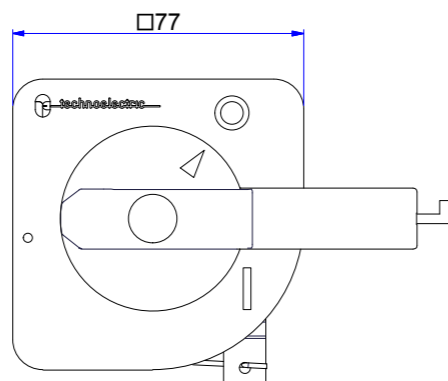
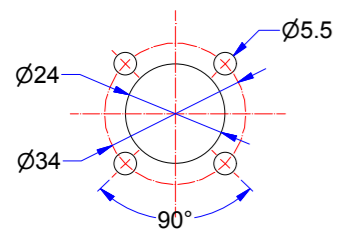

18222

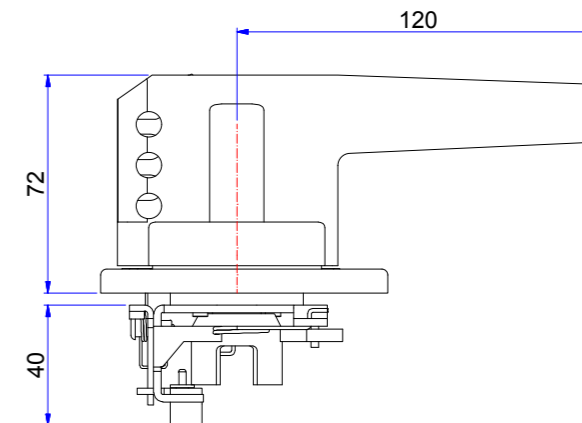

Foratura portella \_Door drilling

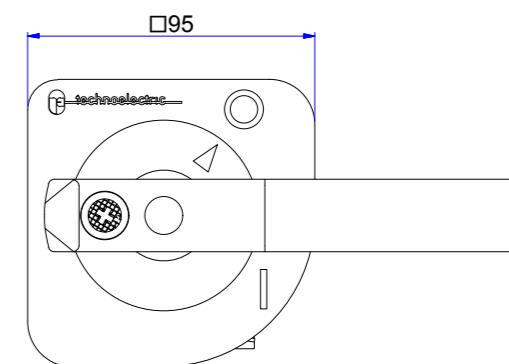
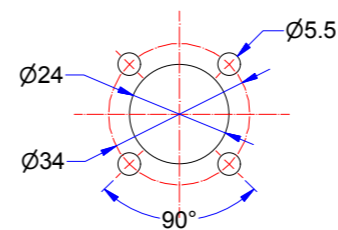

18224

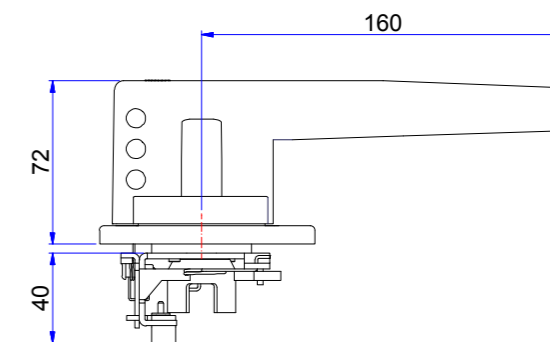

Foratura portella \_Door drilling

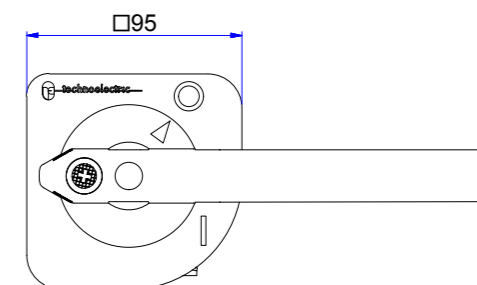
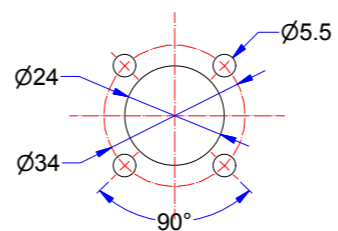

18832

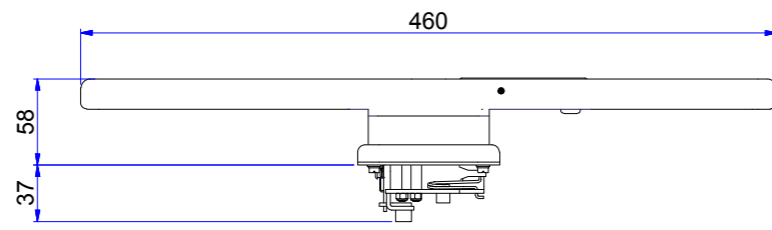

Foratura portella \_Door drilling

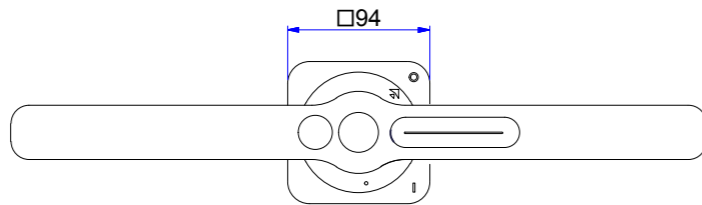
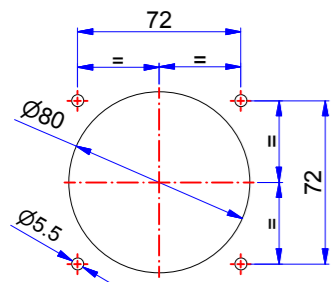

18850

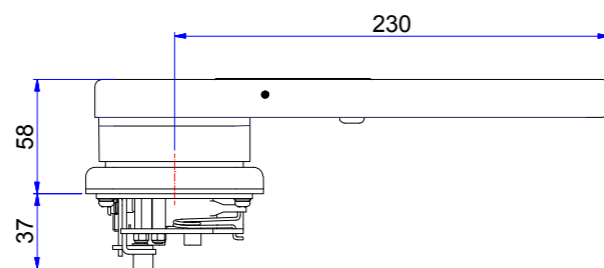

Foratura portella \_Door drilling

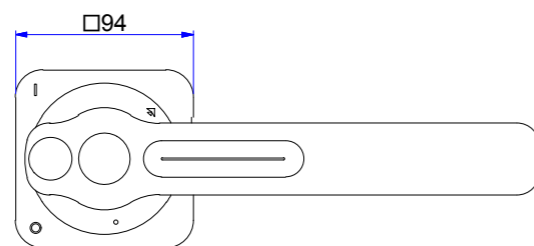
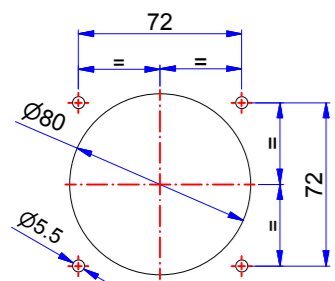

**MANIGLIA BLOCCO PORTA DI EMERGENZA  
CON DISPOSITIVO DI SBLOCCO CON ATTREZZO SPECIALE**  
**\_red/ yellow door interlock handle with defeater mechanism (special tool)**

Tipo_type	VC1P	VC2P	VC3P	VC4P	VC5P	VC5P 50kA	VC6P
Codice_code	18221	18221	18223	18223	18225	18833 18858	18833 18858

18221



Foratura portella \_Door drilling

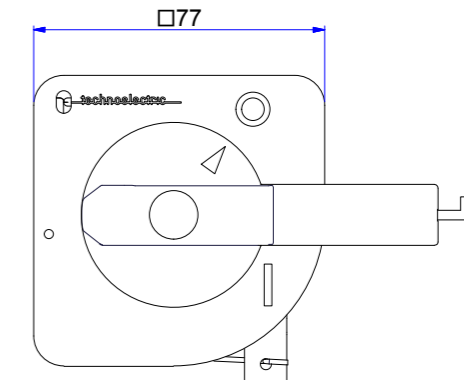
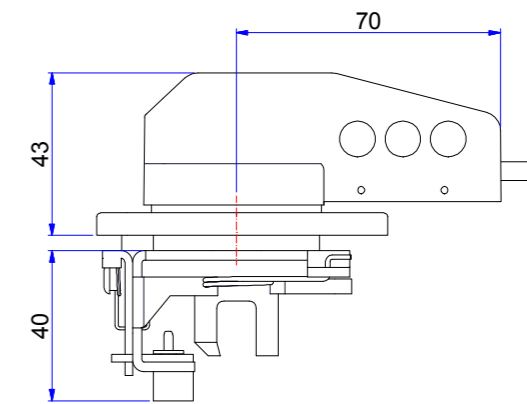
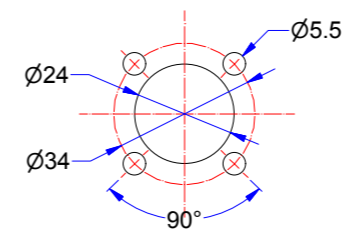

18223



Foratura portella \_Door drilling

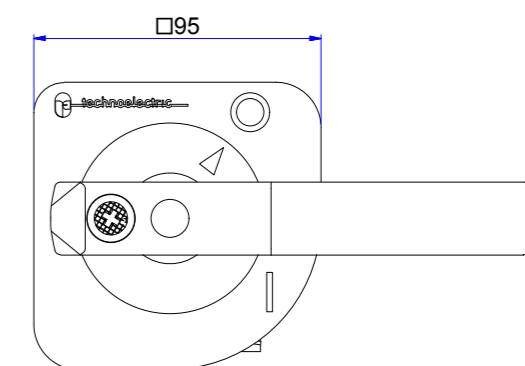
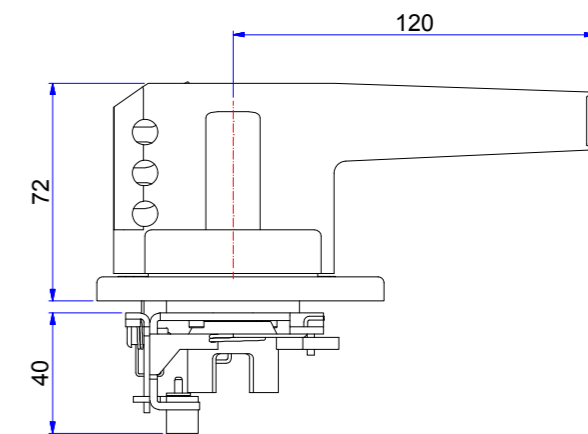
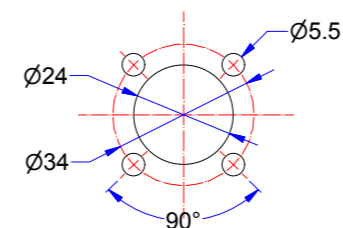

18225

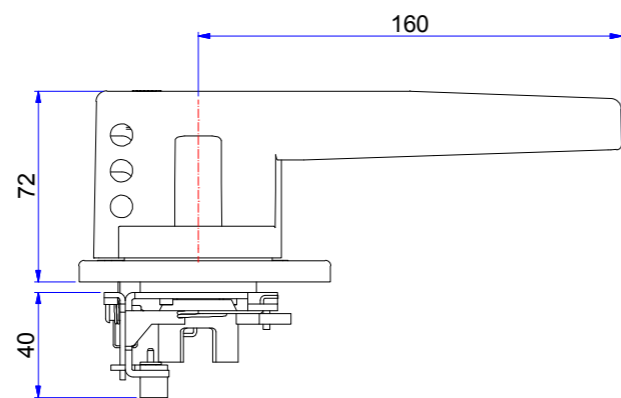

Foratura portella \_Door drilling

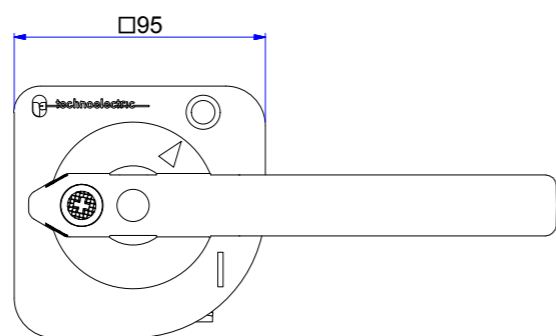
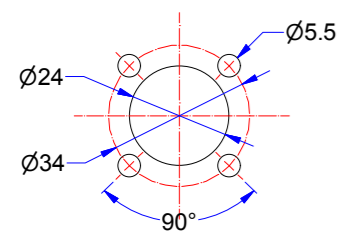

18858

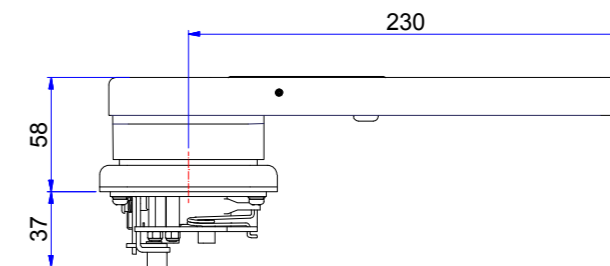

Foratura portella \_Door drilling

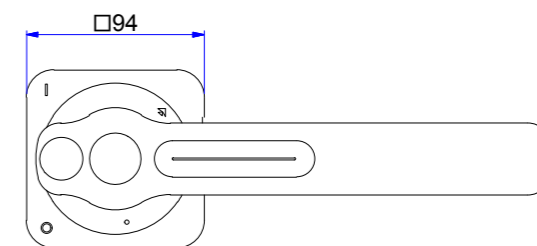
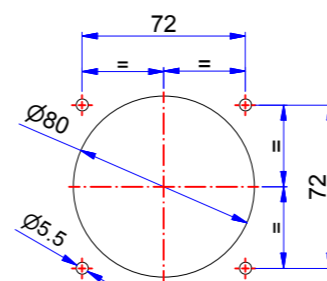

18833

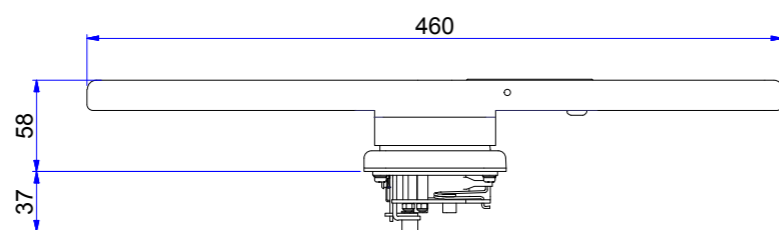

Foratura portella \_Door drilling

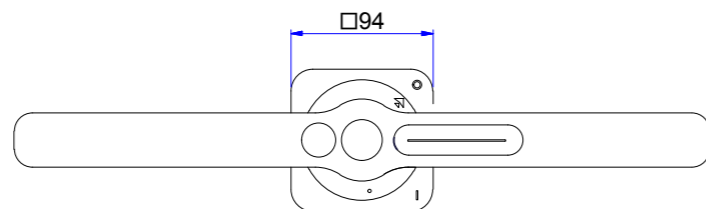
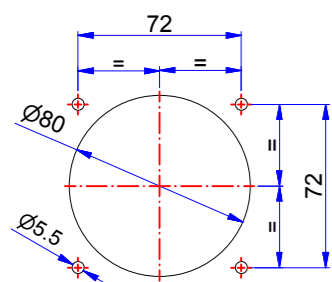



**MANIGLIA BLOCCO PORTA\EMERGENZA  
CON DOPPIA FUNZIONE DI SICUREZZA**

**\_black/emergency compact door interlock handle with  
defeater mechanism**

Tipo_type	VC1P	VC2P	VC3P	VC4P	VC5P 35kA
Codice_code	18234 18235	18234 18235	18234 18235	18236 18237	18236 18237

**18234**

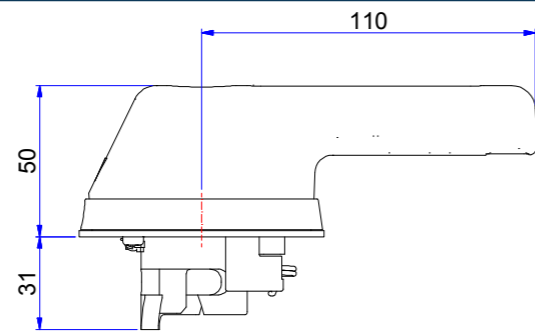

Foratura portella \_Door drilling

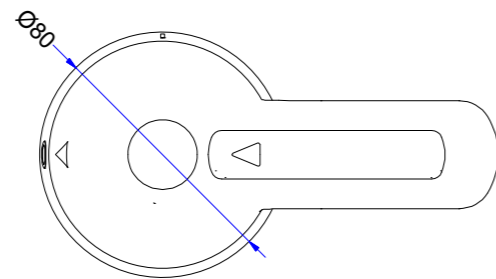
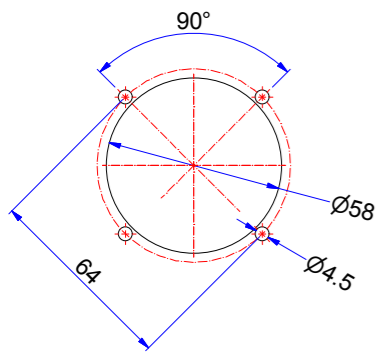

**18236**

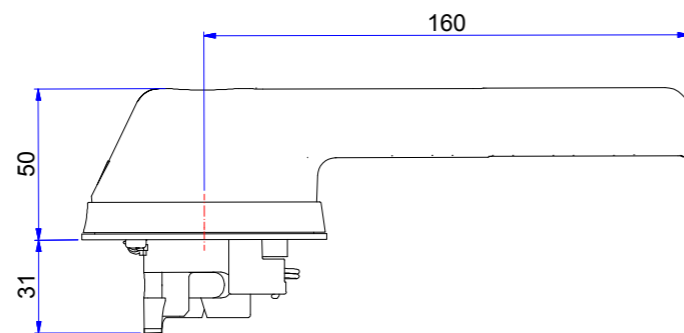

Foratura portella \_Door drilling

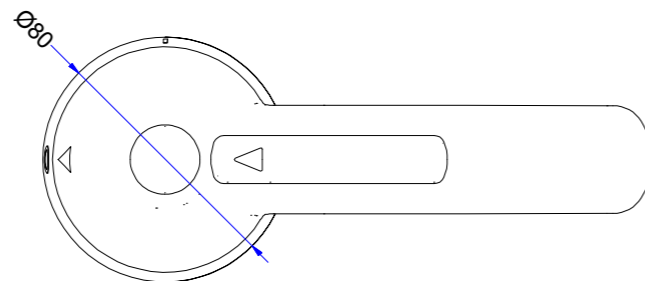
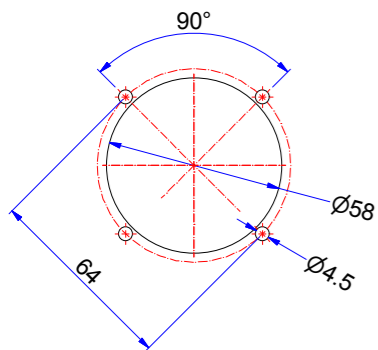

**18235**

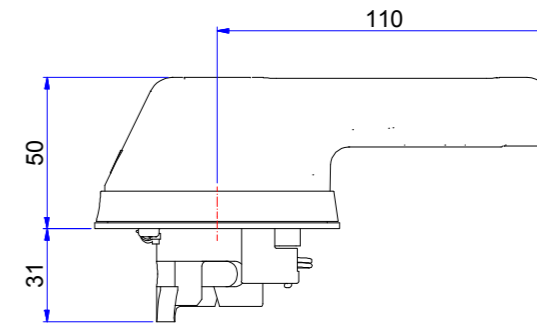

Foratura portella \_Door drilling

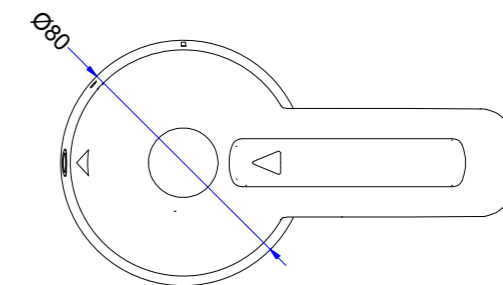
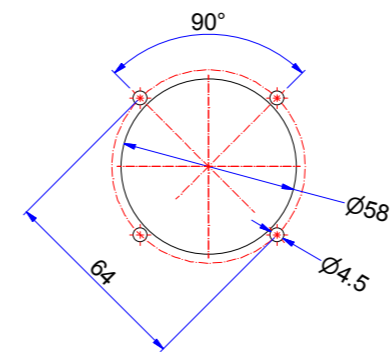

**18837**

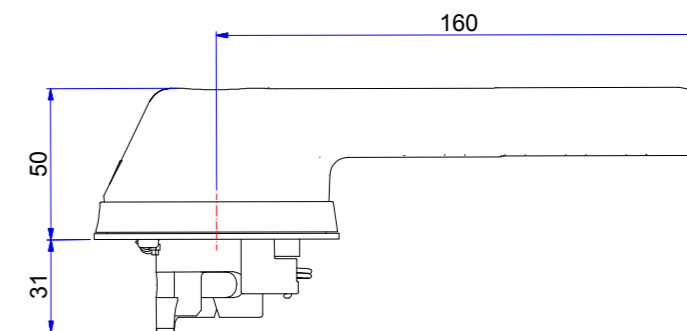

Foratura portella \_Door drilling

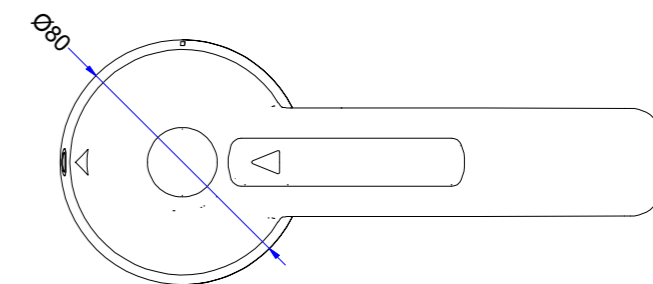
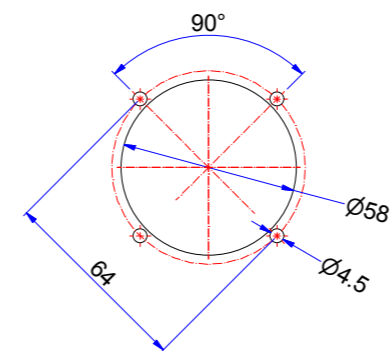

## SERIE\_SERIES VCP

Adatta per montaggio su portella con dispositivo di blocco porta in posizione On Grado di protezione IP 65  
Disponibile anche nella versione per emergenza (rosso/gialla)

\_For door mounting with Door interlocking in "On" position IP 65 degree of protection  
Available also for emergency operation (red\yellow)

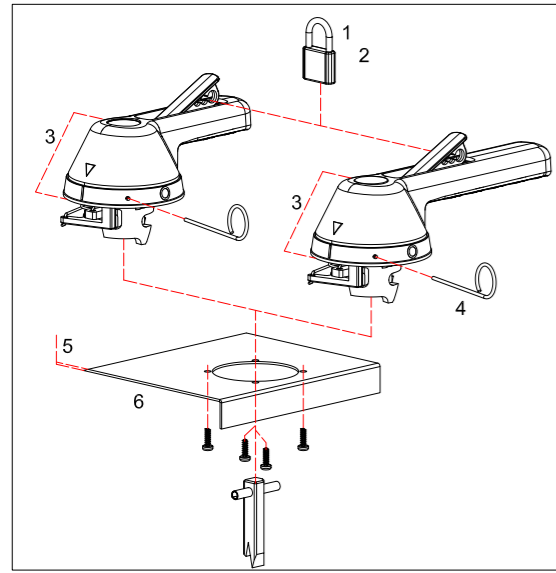

<b>1</b>	Lucchettabile (max 3 lucchetti 1xø8+2xø6) in posizione Off.	Padlockable in "Off" position (with max 3 padlocks of 1xø8+2xø6).
<b>2</b>	Apertura della portella impedita quando la maniglia è lucchettata in posizione di Off.	Door opening is prevented when the handle is padlocked in "Off" position.
<b>3</b>	Ingombro inferiore a 50 mm in profondità per permettere l'utilizzo anche in quadri a doppia portella.	Handle height less than 50 mm for suitability with two-doors type panels.
<b>4</b>	Permette, a mezzo di un apposito attrezzo, fornito con la maniglia, l'esclusione del dispositivo di blocco porta e quindi l'apertura della portella anche a interruttore in posizione di ON. Il dispositivo bloccoporta si ripristina automaticamente al chiudersi della porta.	With the use of the special tool (supplied), the door interlock mechanism can be bypassed maintaining the switch in the "On" position and the door can be opened. The door interlocking mechanism is automatically re-established when door is closed.
<b>5</b>	Può essere montata su portelle di qualsiasi spessore.	Can be mounted on doors of any thickness.
<b>6</b>	Posizione della maniglia fissa quando la portella è aperta.	When the door is open, the position of the handle is fixed

## CONTATTI AUSILIARI IN SCAMBIO 1NA + 1NC PER APERTURA ANTICIPATA

\_auxiliary contacts 1NO + 1NC  
activated before main contacts



18165

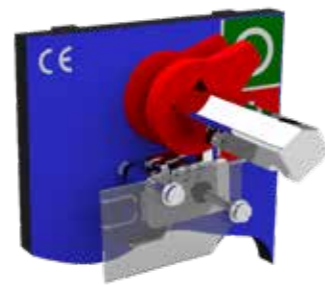

18163

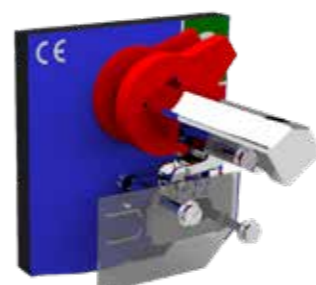

18160

Tipo _type	VC1P	VC2P	VC3P	VC4P	VC5P	VC6P
Codice _code	18165	18165	18163	18160	18163	18163

## CONTATTI AUSILIARI IN SCAMBIO 2NA + 2NC PER APERTURA ANTICIPATA

\_auxiliary contacts 2NO + 2NC  
activated before main contacts

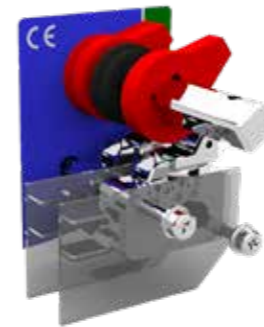

18166

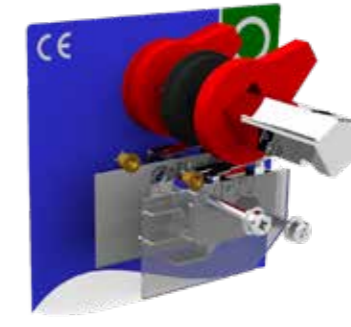

18164

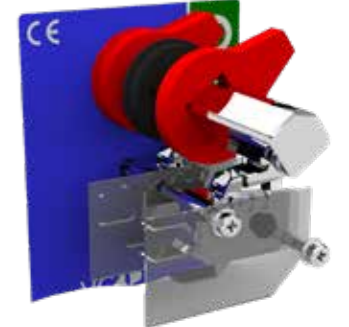

18161

Tipo _type	VC1P	VC2P	VC3P	VC4P	VC5P	VC6P
Codice _code	18166	18166	18164	18161	18164	18164

## CONTATTI AUSILIARI IN SCAMBIO 1NA + 1NC PER APERTURA POSTICIPATA

\_auxiliary contacts 1NO + 1NC  
activated after main contacts

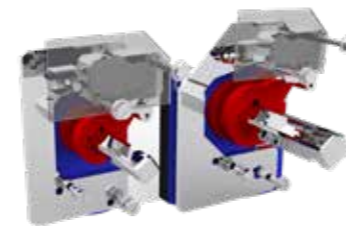

Tipo _type	VC1P	VC2P	VC3P	VC4P	VC5P	VC6P
Codice _code	18120	18120	18127	18127	18127	18127

## CONTATTI AUSILIARI IN SCAMBIO 2NA + 2NC PER APERTURA POSTICIPATA

\_auxiliary contacts 2NO + 2NC  
activated after main contacts

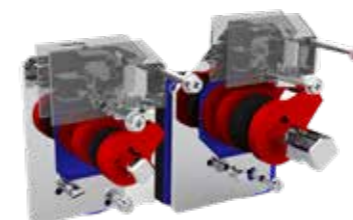

Tipo _type	VC1P	VC2P	VC3P	VC4P	VC5P	VC6P
Codice _code	18123	18123	18128	18128	18128	18128

## SERIE\_SERIES VCP

Contatti ausiliari in scambio  
Apertura anticipata rispetto  
all'apertura dei contatti  
principali dell'interruttore Portata  
nominale 16A  
Portata termica 20A

\_Change over auxiliary contacts  
break before make contacts switches  
Rated current 16A  
Thermal current 20A

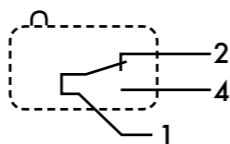
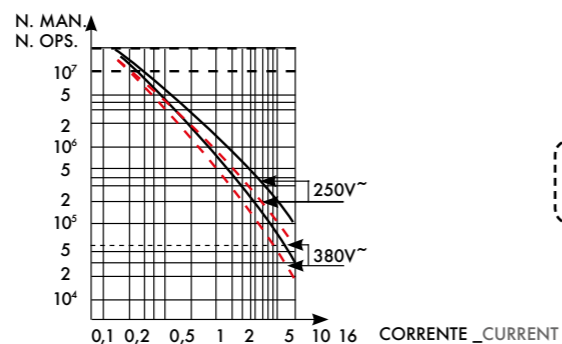

## CONTATTI AUSILIARI IN SCAMBIO 2NA+2NC \_auxiliary contacts 2NO+2NC

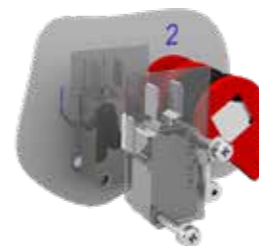

Tipo_type	EO3 - EO4 - EO5	ES3 - ES4 - ES5
Codice_code	18567 (rotella_roll)	

## CONTATTI AUSILIARI IN SCAMBIO 1NA+1NC \_auxiliary contacts 1NO+1NC

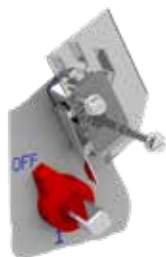

Tipo_type	EO1	EO2	ES1	ES2
Codice_code	18566 (paletta_lever)			

## CALOTTA PROTEZIONE TERMINALI SUPERIORI \_upper terminal cover

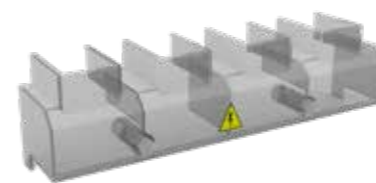

Tipo_type	VC1P	VC2P	VC3P	VC4P	VC5P	VC5P 50 kA max 1600 A
Codice_code	18050	18052	18350	18054	18056	18058

## CONTATTI AUSILIARI IN SCAMBIO 1NA+1NC \_auxiliary contacts 1NO+1NC



Tipo_type	EO3 - EO4 - EO5	ES3 - ES4 - ES5
Codice_code	18560 (rotella_roller)	

## CALOTTA PROTEZIONE TERMINALI INFERIORI \_lower terminal cover

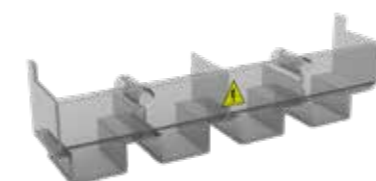

Tipo_type	VC1P	VC2P	VC3P	VC4P	VC5P	VC5P 50 kA max 1600 A
Codice_code	18051	18053	18351	18055	18057	18059

## CONTATTI AUSILIARI IN SCAMBIO 2NA+2NC \_auxiliary contacts 2NO+2NC



Tipo_type	EO1	EO2	ES1	ES2
Codice_code	18568 (paletta_lever)			

## SCHERMO PROTEZIONE CONTATTI PRINCIPALI \_main contacts cover shield

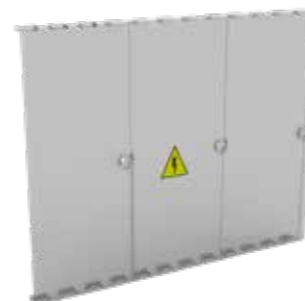

Tipo_type	VC1P	VC2P	VC3P	VC4P	VC5P	VC6P
Codice_code	18060	18061	18360	18062	18063	18063

**SPESSORE RIALZO**  
**\_risers**



Tipo _type	VC1P	VC2P	VC3P	VC4P	VC5P	VC6P
Codice _code	18290	18291	18292	18293	18293	18293
Tipo _type	h/mm		Ø			
VC1	5		15			
VC2	5		18			
VC3	10		17			
VC4-5	15		24			

**NEUTRO SBULLONABILE**  
**\_fuse link**



Tipo _type	VC1P	VC2P	VC3P	VC4P	VC5P	VC6P
Codice _code	18110	18111	18112	18113	18114	18114

**BLOCCO MANOVRA ELETTRICO**  
**\_electric interlock**

Tipo _type	Tensione _voltage	VC2P	VC3P	VC4P	VC5P	VC5P 1600÷2000A	VC5P 2500÷3150A	VC6P 1600÷2000A	VC6P 2500A	VC6P 3150A
Codice _code	24 V dc	18119B	18117B	18116B	18115B	18178B	18179B	18156B	18157B	18158B
	230 V ac	18119B4	18117B4	18116B4	18115B4	18178B4	18179B4	18156B4	18157B4	18158B4

altre tensioni a richiesta \_further versions upon request

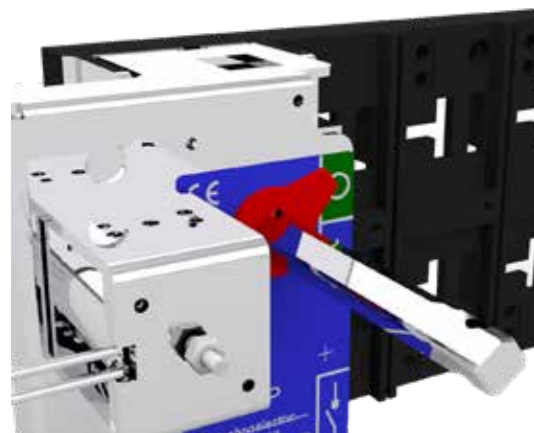

Dispositivo di sicurezza adatto per il montaggio su interruttori di manovra sezionatori VC2-3-4-5-6P. Impedisce la manovra quando l'interruttore è in posizione Off. La monovra da Off a On è consentita solo alimentando la bobina.  
La bobina deve essere alimenta solo per il tempo necessario alla manovra. Disponibili nelle versioni con bobina 24 V dc oppure 220 V ac. A richiesta può essere fornito un dispositivo per blocco sia in posizione On che in posizione Off.

\_Safety device suitable for mounting on switch disconnectors VC2-3-4-5-6P. It prevents the switch to operate when it is in Off position. The operation from Off to On is possible when the coil is energised only. The coil can remain energised just for the time needed for the operation. Available with 24 V dc or 220 V ac coil.  
Device for locking in both positions available under request.

**ATTACCHI A SBARRE PER VC5P 800 ÷ 3150A**  
**\_large bar terminals for VC5P 800 ÷ 3150A**

Tipo _type	VC5P 3 x 800 ÷ 1250A	VC5P 3 x 1600 ÷ 2000A	VC5P 3 x 2500 ÷ 3150A	VC5P 4 x 800 ÷ 2000A	VC5P 4 x 1600 ÷ 2000A	VC5P 4 x 2500 ÷ 3150A
Codice _code	18154	18150	18151	18155	18152	18153

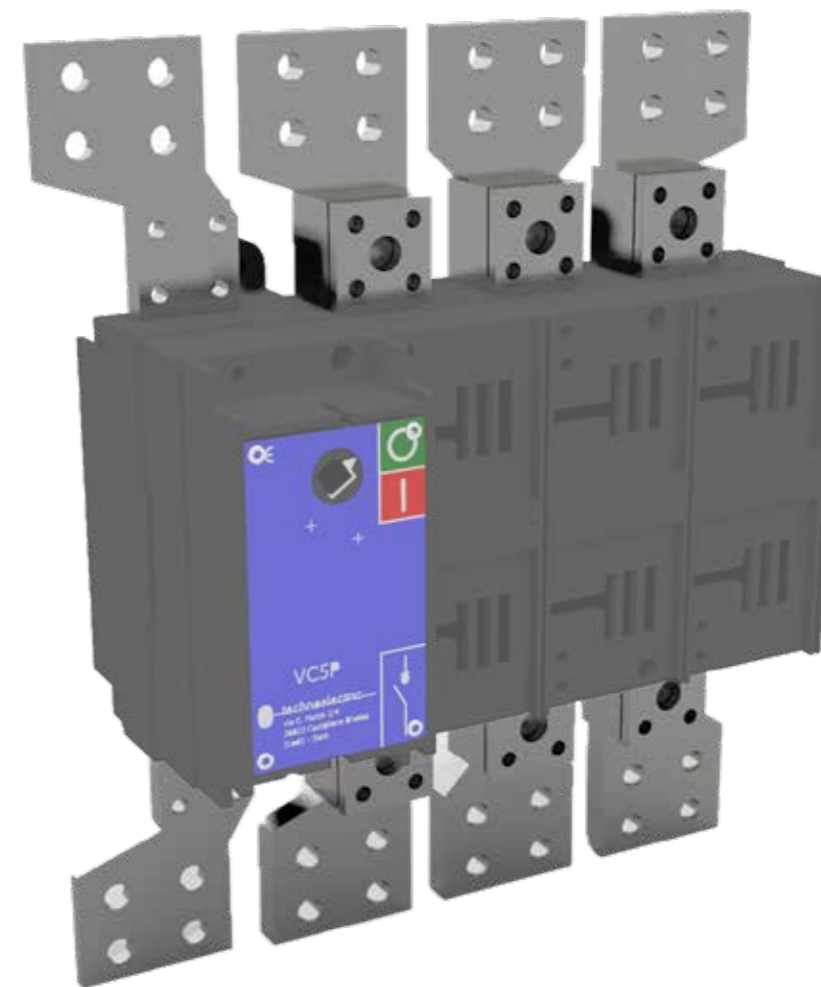

**PIATTO PER TERMINALI SEZIONATORI**  
**\_terminal plate for switches**



Tipo _type	VC5P 4MM	VC5P 6MM
Codice _code	18138	18139

La confezione contiene 1 piatto per terminali  
\_Each box contain a terminal plate





# INTERRUTTORI DI MANOVRA SEZIONATORI CON PORTAFUSIBILI

## SWITCH DISCONNECTORS FUSES

**VCF 32 ÷ 800 A**



## SERIE\_SERIES VCF

### GENERALITÀ

VISUALCOMPACT F è una serie di interruttori di manovra sezionatori con portafusibili che consentono l'apertura e la chiusura di circuiti elettrici in bassa tensione. Sono comunemente impiegati per le seguenti funzioni:

- interruttore generale
- interruttore per motori
- sezionatore
- interruttore di sicurezza

Sono disponibili 5 grandezze per 13 diversi valori di corrente nominale.

### CARATTERISTICHE GENERALI

Tensione di isolamento nominale 1500v c.A. E 1500v c.C.  
Disponibili 3 - 4 poli  
Alto potere di interruzione (AC-22, AC-23, IEC 60947-3)  
Elevata durata meccanica ed elettrica  
Quattro interruzioni per ogni polo  
Contatti autopulenti  
Basi portafusibili isolate su entrambi i lati con interruttore aperto  
Possibilità di montaggio fusibili tipo DIN, BS e NFC  
Posizione della maniglia che costituisce un'indicazione positiva e affidabile della posizione dei contatti  
Visibilità diretta mediante finestrelle, dei contatti fissi e mobili  
Manovra a scatto rapido indipendente  
Polo neutro con contatti ad apertura posticipata e chiusura anticipata rispetto ai contatti di fase  
Disponibile versione con polo neutro passante  
Protezione adeguata per prevenire contatti accidentali  
Involucro in materiali autoestinguenti (classe V0-UL94) a bassa igroscopicità, ad alta resistenza meccanica e alle correnti superficiali  
Adatto per utilizzo in climi tropicali  
Ampia gamma di accessori  
Comando di tipo rotativo frontale a mezzo di: maniglia esterna a doppio isolamento con blocco porta in posizione I, grado di protezione IP65, possibilità di 3  
Blocchi con lucchetto in posizione 0  
Maniglia diretta (a richiesta lucchettabile in posizione 0)

### CONDIZIONI NORMALI DI SERVIZIO, MONTAGGIO E TRASPORTO

Temperatura ambiente di immagazzinamento e trasporto - 25°C + 55°C  
Temperatura ambiente di funzionamento - 20°C + 40°C  
In caso di temperatura ambiente ( $t_a$ ) superiore, applicare la seguente formula di declassamento:

$$I_{the} = k i_{th} \text{ dove } k = 1 - \frac{t_a - 40}{100}$$

Umidità relativa max 95%  
Frequenza nominale 50 - 60 hz  
Altitudine max 2000 m s.l.m.  
Grado di inquinamento 3 secondo IEC 60947-1  
Possono essere montati in qualsiasi posizione, per posizionamento fare riferimento alla istruzioni di montaggio  
Montaggio in custodia: in caso di utilizzo a piena corrente e in mancanza di adeguata ventilazione assicurare un volume pari a circa 5 volte quello dell'apparecchio  
Tipo di servizio (secondo IEC 60947-1): 8 ore; ininterrotto; intermittente 60% classe 30; temporaneo; periodico.  
Per condizioni di impiego diverse consultare il costruttore.

### CONFORMITÀ ALLE NORME

IEC 60947-1|IEC 60947-3|UNI EN 60947-1|UNI EN 60947-3

### CERTIFICATI E OMOLOGAZIONI

KEMA | RINA | ENEL codice 13.32.23 | A2A | CESI | IENGF | EAC

### \_GENERALITIES

VISUALCOMPACT F is a range of fuse switch disconnectors suitable for making and breaking on load and disconnecting low voltage electrical circuits. They are commonly used for the following purposes:

- main switch
- switch for motors
- disconnecter
- safety switch

They are available in 5 sizes and 13 current ratings.

### \_GENERAL CHARACTERISTICS

Rated insulation voltage 1500v AC and 1500v DC  
3 - 4 Poles available  
High breaking capacity (AC-22, AC-23, IEC 60947-3)  
High electrical and mechanical endurance  
Four break contacts  
Self cleaning contacts  
Both fuse terminals are not alive when the switch is in O position  
Suitable for DIN, BS and NFC fuses  
Contact position positively indicated by the handle  
Visibility of fixed and moving contacts by means of windows  
Independent manual operation  
Neutral contact makes earlier and opens later than the phase contacts  
Solid neutral version available  
Suitable protection to prevent accidental touching of live parts  
Casing in self-extinguishing (V0-UL94), low hygroscopic and high mechanical resistance isolating material resistant to damp heat  
Wide range of accessories  
Rotary front operation by means of: external double insulated handle with door-interlock in ON position, IP65 degree of protection. Padlockable with three padlocks in OFF position  
Direct handle (padlockable in OFF position on request)

### \_NORMAL SERVICE, MOUNTING AND TRANSPORT CONDITIONS

Storage and transport ambient temperature - 25°C + 55°C  
Working ambient temperature - 20°C + 40°C  
In case of higher ambient temperature ( $t_a$ ) consider the following derating formula:

$$I_{the} = k i_{th} \text{ where } k = 1 - \frac{t_a - 40}{100}$$

Relative humidity max 95%  
Rated frequency 50 - 60 hz  
Altitude max 2000 m a.s.l.  
Pollution degree 3 according IEC 60947-1  
Can be mounted in any position, for what concerns the positioning, please refer to the installation instructions  
Mounting in enclosure: in case of utilisation at full load and without adequate ventilation, ensure a volume of about 5 times the volume of the switch  
Duty (IEC 60947-1): 8 hours; uninterrupted; intermittent 60% class 30; temporary; periodic.

For different operating conditions, please contact the manufacturer.

### \_CONFORMITY TO STANDARDS

IEC 60947-1|IEC 60947-3|UNI EN 60947-1|UNI EN 60947-3

### \_CERTIFICATES AND APPROVALS

KEMA | RINA | ENEL code 13.32.23 | A2A | CESI | IENGF | EAC



Fuori standard BS  
Albero di comando standard  
lunghezza 200 mm incluso in ogni confezione.

\_Not BS standard  
Standard shaft length 200 mm included in the package.

Sono disponibili interruttori di manovra-sezionatori con portafusibili a 6-8 poli. Per informazioni contattare TECHNOELECTRIC.

\_Available switch disconnectors fuse 6-8 poles version. For information contact TECHNOELECTRIC.

Tipo _type	Corrente nominale _rated current	Tipo di fusibile Fuse type				Senza maniglia _without handle			Maniglia blocco porta _door interlock handle		
		NFC	DIN	BS	POLE POLES	NFC	DIN	BS	NFC	DIN	BS
VC1F	32A	14x51	NH C00	A2	3	11020SM	11040SM	11060SM	11020	11040	11060
				A2 - A3	4	11030SM	11050SM	11070SM	11030	11050	11070
	45A	14x51	NH C00	A2 - A3	3	11021SM	11041SM	11061SM	11021	11041	11061
				A2 - A3	4	11031SM	11051SM	11071SM	11031	11051	11071
	63A	22x58	NH C00	A2 - A3	3	11022SM	11042SM	11062SM	11022	11042	11062
				A2 - A3	4	11032SM	11052SM	11072SM	11032	11052	11072
	80A	22x58	NH C00	ODS	3	11023SM	11043SM	11063SM	11023	11043	11063
				ODS	4	11033SM	11053SM	11073SM	11033	11053	11073
	100A	22x58	NH C00	ODS	3	11024SM	11044SM	11064SM	11024	11044	11064
				ODS	4	11034SM	11054SM	11074SM	11034	11054	11074
VC2F	100A	22x58	NH 00	A4	3	12021SM	12041SM	12060SM	12021	12041	12060
				A4	4	12031SM	12051SM	12070SM	12031	12051	12070
	125A	22x58	NH 00	DEO	3	12022SM	12042SM	12061SM	12022	12042	12061
				DEO	4	12032SM	12052SM	12071SM	12032	12052	12071
			NH 0		3	-	12044SM	-	-	12044	-
					4	-	12054SM	-	-	12054	-
	160A		NH 00	DEO	3	-	12043SM	12062SM	-	12043	12062
				DEO	4	-	12053SM	12072SM	-	12053	12072
			NH 0		3	-	12045SM	-	-	12045	-
					4	-	12055SM	-	-	12055	-
VC3F	200A		NH 1	B1-B2	3	-	13041SM	13061SM	-	13041	13061
				B1-B2	4	-	13051SM	13071SM	-	13051	13071
	250A		NH1	B1-B3	3	-	13042SM	13062SM	-	13042	13062
				B1-B3	4	-	13052SM	13072SM	-	13052	13072
VC4F	315A		NH 2	B1-B3	3	-	14022SM	14042SM	-	14022	14042
				B1-B3	4	-	14032SM	14052SM	-	14032	14052
	400A		NH 2	B1-B4	3	-	14023SM	14043SM	-	14023	14043
				B1-B4	4	-	14033SM	14053SM	-	14033	14053
VC5F	630A		NH 3	C2	3	-	15020SM	15040SM	-	15020	15040
				C2	4	-	15030SM	15050SM	-	15030	15050
	800A		NH 3	C3	3	-	15022SM	15041SM	-	15022	15041
				C3	4	-	15032SM	15051SM	-	15032	15051

**SERIE\_SERIES VCF**

Caratteristiche tecniche _Technical Features	Tipo _Type		VC1F					VC2F		
Corrente nominale _Rated current	In	A	32	45	63	80	100	100	125	160
Tensione nominale d'isolamento _Rated insulation voltage	Ui	V	1500	1500	1500	1500	1500	1500	1500	1500
Tensione nominale impulso _Shock resistance	U imp	kV	8	8	8	8	8	12	12	12
Corrente nominale termica _Thermal current	Ith	A	32	45	63	80	100	100	125	160
Corrente nominale d'impiego _Rated operational current										
AC-21A	400V	A	32	45	63	80	100	100	125	160
	500V	A	32	45	63	80	100	100	125	160
	690V	A	32	45	63	80	100	100	125	160
AC-22A	400V	A	32	45	63	80	80	100	125	160
	500V	A	32	45	63	80	80	100	125	160
	690V	A	32	45	63	80	80	100	125	160
AC-23A	400V	A	32	45	63	80	80	100	125	160
	500V	A	25	35	45	63	63	80	100	125
	690V	A	20	25	32	45	45	63	80	100
DC-21A	48V	A	32	50	63	80	100	100	125	160
	110V	A	32	50	63	80	100	100	125	160
	220V	A	32	50	63	80	100	100	125	160
	400V	A	-	-	-	-	-	100	125	160
	500V	A	-	-	-	-	-	100	125	160
	600V	A	-	-	-	-	-	-	-	-
DC-22A	48V	A	32	50	63	80	80	100	125	160
	110V	A	32	50	63	80	80	100	125	160
	220V	A	32	50	63	80	80	100	125	160
	400V	A	-	-	-	-	-	100	125	160
	500V	A	-	-	-	-	-	100	125	160
	600V	A	-	-	-	-	-	-	-	-
DC-23A	48V	A	32	50	63	80	80	100	125	160
	110V	A	32	50	50	63	80	100	125	160
	220V	A	32	50	50	50	63	100	125	160
	400V	A	-	-	-	-	-	100	125	160
Potenza nominale d'impiego _Rated operational power AC23 - A	400V	kW	17	23	33	42	42	52	65	85
Corrente di corto circuito condizionata da fusibile _Rated fuse short-circuit current										
Tipo fusibile _Backup fuse		A	32	45	63	80	80	100	125	160
Valore efficace _R.M.S. value		kA	50	50	50	50	50	50	50	50
Valore di picco _Peak value		kA	6	9	10	12	12	12	15	15
Potere di chiusura nominale _Rated making capacity	420V cosØ 0,35 (0,45*)	A	320*	450*	630*	800*	800*	1000*	1250	1600
Potere di interruzione nominale _Rated breaking capacity	420V cosØ 0,35 (0,45*)	A	256*	360*	504*	640*	640*	800*	1000	1280
Potere di chiusura e interruzione nominale c.c. _Road making and breaking capacity DC	230V L/R=15	A	80	120	140	180	180	252	320	400
Potenza condensatori _Rated capacitor power at 400V		kVAR	15	20	30	40	45	45	50	70
Durata meccanica _Mechanical endurance		n.	10000	10000	10000	10000	10000	8000	8000	8000
Durata elettrica _Electrical endurance		n.	1500	1500	1500	1500	1500	1000	1000	1000
Potenza dissipata per polo _Power losses for pole*		W	1,2	1,2	1,2	1,2	1,2	4,8	4,8	4,8
Dimensione cavo _Cable section		mmq	10	10	16	25	35	35	50	70
Dimensione barre _Bars dimension		MM	12x2	12x2	12x3	12x3	14x3	16x3	16x4	16x4
Sforzi di manovra _Operating torque		Nm	8	8	8	8	8	12	12	12
			8	8	8	8	8	8	12	12
Peso netto _Net weight		Kg	1	1	1	1	1	1,9	1,9	1,9
			1,1	1,1	1,1	1,1	1,1	2	2	2

Caratteristiche tecniche _Technical Features	Tipo _Type		VC3F		VC4F		VC5F	
Corrente nominale _Rated current	In	A	200	250	315	400	630	800
Tensione nominale d'isolamento _Rated insulation voltage	Ui	V	1500	1500	1500	1500	1500	1500
Tensione nominale impulso _Shock resistance	U imp	kV	12	12	12	12	12	12
Corrente nominale termica _Thermal current	Ith	A	200	250	315	400	630	800
Corrente nominale d'impiego _Rated operational current								
AC-21A	400V	A	200	250	315	400	630	800
	500V	A	200	250	315	400	630	800
	690V	A	200	250	315	400	630	800
AC-22A	400V	A	200	250	315	400	630	800
	500V	A	200	250	315	400	630	800
	690V	A	200	250	315	400	630	800
AC-23A	400V	A	200	250	315	400	630	630
	500V	A	160	200	250	315	500	500
	690V	A	125	160	200	250	400	400
DC-21A	48V	A	200	250	315	400	630	800
	110V	A	200	250	315	400	630	800
	220V	A	200	250	315	400	630	800
	400V	A	200	250	315	400	630	630
	500V	A	200	250	315	400	630	630
	600V	A	-	-	315	400	630	630
DC-22A	48V	A	200	250	315	400	630	800
	110V	A	200	250	315	400	630	800
	220V	A	200	250	315	400	630	800
	400V	A	200	250	315	400	630	630
	500V	A	200	250	315	400	630	630
	600V	A	-	-	315	400	630	630
DC-23A	48V	A	200	250	315	400	630	630
	110V	A	160	200	315	315	500	500
	220V	A	160	160	250	250	400	400
	400V	A	-	-	-	-	-	-
Potenza nominale d'impiego _Rated operational power AC23 - A	400V	kW	105	130	165	210	330	420
Corrente di corto circuito condizionata da fusibile _Rated fuse short-circuit current								
Tipo fusibile _Backup fuse		A	200	250	315	400	630	800
Valore efficace _R.M.S. value		kA	50	50	50	50	50	50
Valore di picco _Peak value		kA	20	25	25	30	40	40
Potere di chiusura nominale _Rated making capacity	420V cosØ 0,35 (0,45*)	A	2000	2500	3150	4000	6300	8000
Potere di interruzione nominale _Rated breaking capacity	420V cosØ 0,35 (0,45*)	A	1600	2000	2520	3200	5040	6400
Potere di chiusura e interruzione nominale c.c. _Road making and breaking capacity DC	230V L/R=15	A	500	640	800	1000	1600	2000
Potenza condensatori _Rated capacitor power at 400V		kVAR	90	110	140	180	300	370
Durata meccanica _Mechanical endurance		n.	7000	7000	7000	7000	4000	4000
Durata elettrica _Electrical endurance		n.	1000	1000	1000	1000	1000	1000
Potenza dissipata per polo _Power losses for pole*		W	12	12	19,2	19,2	30	30
Dimensione cavo _Cable section		mmq	95	120	185	240	2x185	2x240
Dimensione barre _Bars dimension		MM	25x5	25x6	32x6	2x25x5	2x40x5	2x40x6
Sforzi di manovra _Operating torque		Nm	18	18	34	34	45	45
			18	18	34	34	45	45
Peso netto _Net weight		Kg	5	5	7	7	13	13
			5,3	5,3	7,4	7,4	14,5	14,5

VC1F

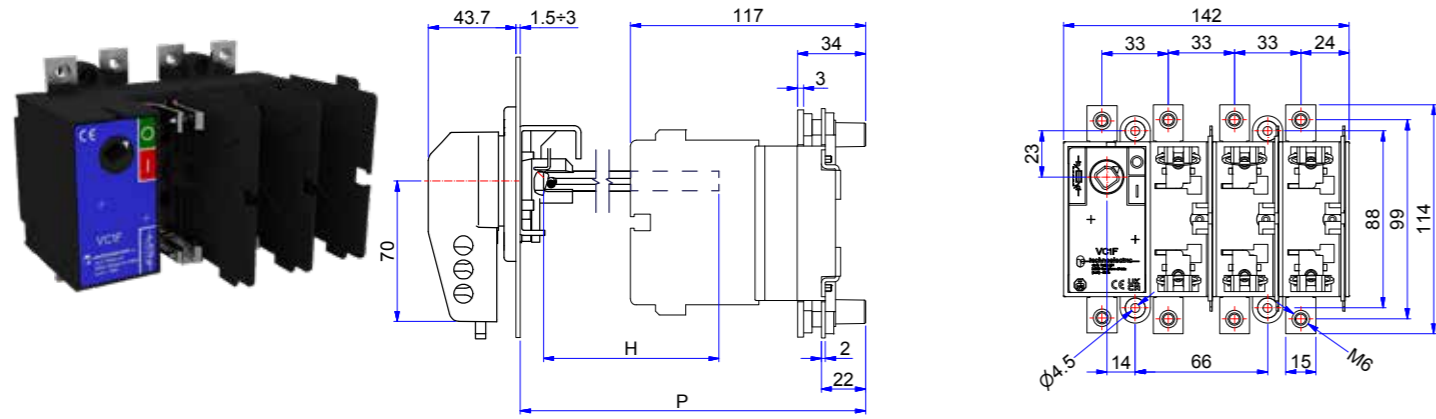

Legenda \_caption

VC1F 32 ÷ 100A

P		C	H
min	max		
115,2	260,5	60,5	P-C

C= costante\_ constant

Foratura portella \_Door drilling

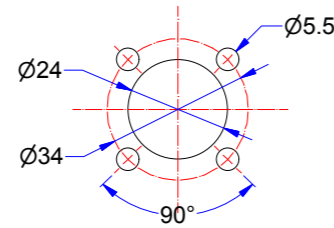

VC3F

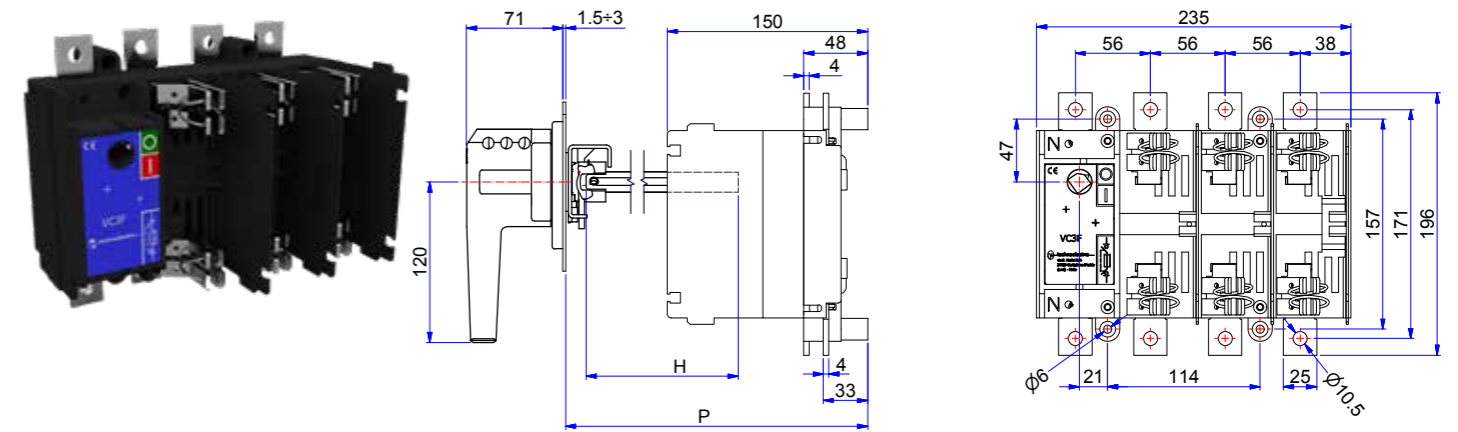

Legenda \_caption

VC3F 200 ÷ 250A

P		C	H
min	max		
189	280,5	71,5	P-C

C= costante\_ constant

Foratura portella \_Door drilling

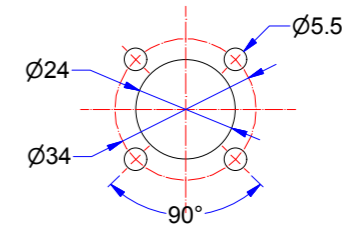

VC2F

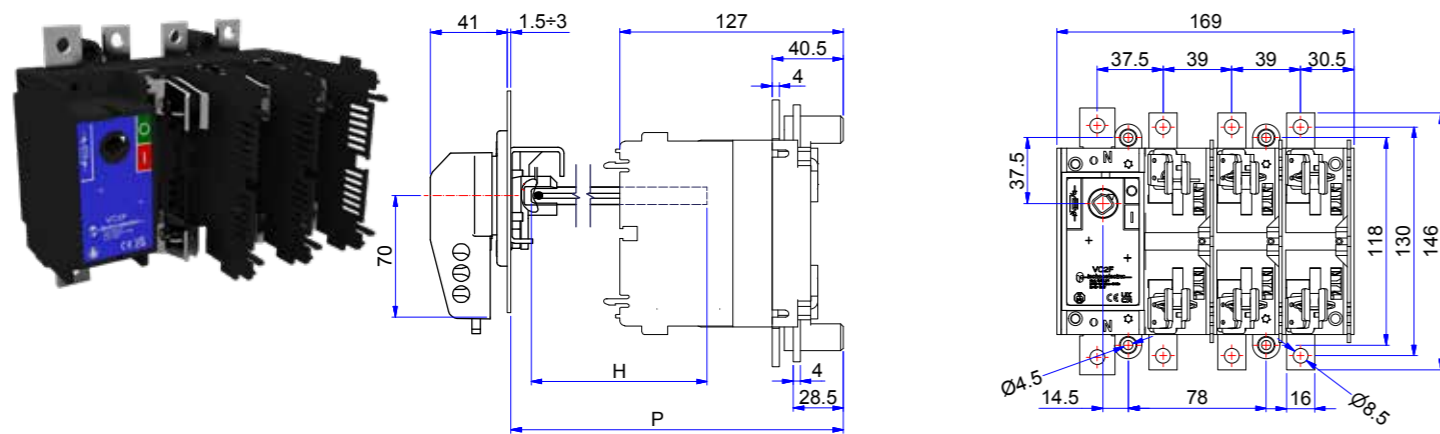

Legenda \_caption

VC2F 100 ÷ 160A

P		C	H
min	max		
165,5	268,5	68,5	P-C

C= costante\_ constant

Foratura portella \_Door drilling

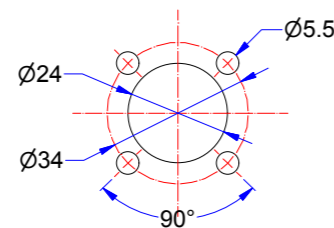

VC4F

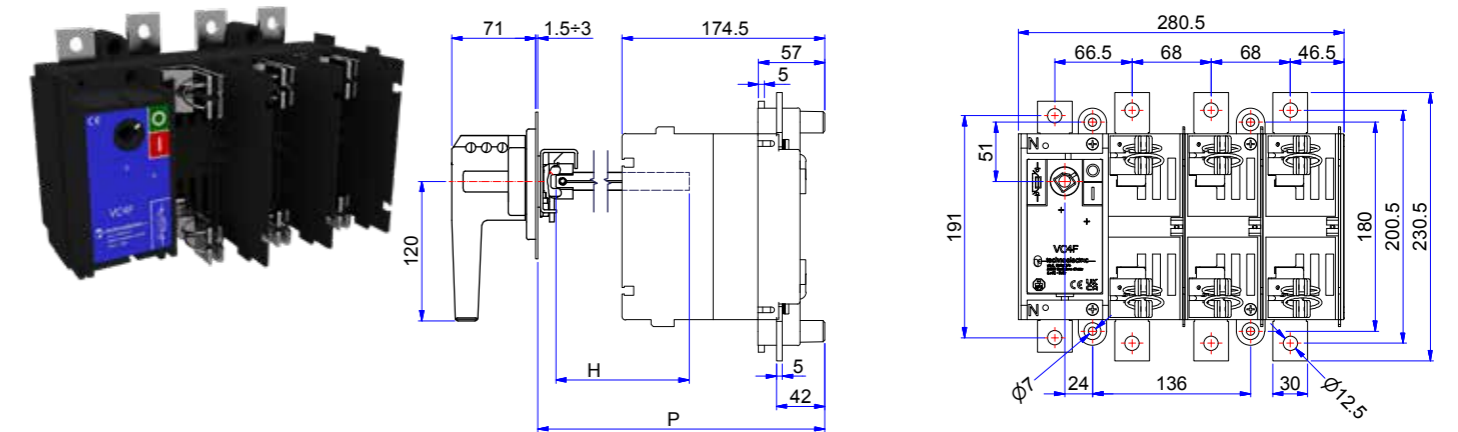

Legenda \_caption

VC4F 315 ÷ 400A

P		C	H
min	max		
215	296	96	P-C

C= costante\_ constant

Foratura portella \_Door drilling

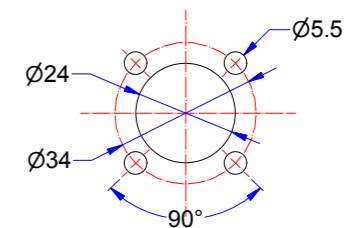



VC5F

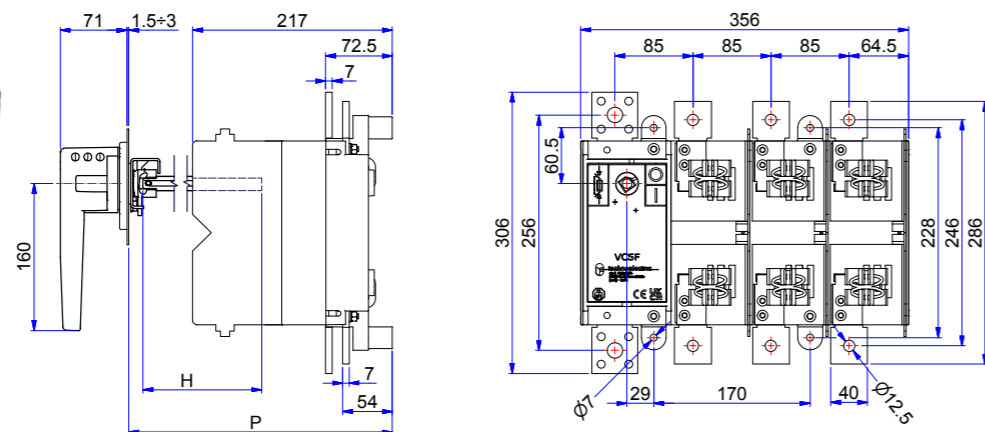

**Legenda \_caption**  
VC5F 630 ÷ 800 A

P		C	H
min	max		
257	320	120	P-C

C= costante\_ constant

Foratura portella \_Door drilling

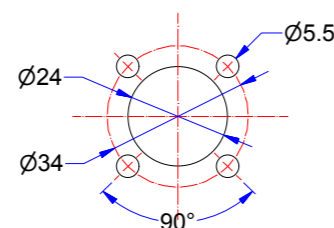

**IMPIEGO E ABBINAMENTO DEI FUSIBILI A COLTELLO "UR DIN 43620" CON SEZIONATORI VISUAL COMPACT F STANDARD**

L'abbinamento tra i sezionatori della serie VCF e i fusibili della serie UR a coltello pieno DIN 43620 consentono l'apertura o la chiusura sotto carico e il sezionamento di sicurezza, nonché la protezione di apparati elettronici di potenza (semiconduttori, raddrizzatori, inverter ecc.). La possibilità d'impiego dei sezionatori standard consente un notevole risparmio economico e di gestione. Le prestazioni corrette si ottengono attenendosi scrupolosamente ai valori e modelli definiti dai nostri test, e riportati nella tabella di abbinamento fusibili UR Coltello DIN 43620 \ INT - SEZ VCF standard.

**USE AND COMBINATION FUSES "UR KNIFE DIN 43620" AND STANDARD VCF SWITCHES**

The combination between the switches VCF serie and fuses UR serie full knife DIN 43620 allow making and breaking operations under load and safety disconnecter and protection of power electronic devices (semiconductors, rectifiers, inverters etc). The possibility of use of Standard switches allows remarkable economic saving and of management. The correct performances are obtained scrupulously following the values and types of our tests, showing in the combination table fuses UR knife DIN 43620\standard switch VCF.

**Tabella di abbinamento dei fusibili UR a coltello pieno DIN 43620 e i sezionatori con porta fusibili standard VCF**

**\_Combination table fuses UR full knife DIN 43620 and standard switch VCF**

Tipo sezionatore _switch type	Corrente nominale A _rated current A	Tipo Fusibile _fuse type UR DIN 43620 I max A	Taglia fusibile _size fuse
VC2F	100	40	NH00
VC2F	125	80/90	NH00 - NH0
VC2F	160	100	NH00 - NH0
VC3F	200	140	NH1
VC3F	250	170	NH1
VC4F	315	260	NH2
VC4F	400	290	NH2
VC5F	630	450	NH3
VC5F	800	500	NH3

# VCF con attacchi laterali \_VCF with side connections



Tipo _type	Corrente nominale _rated current	Tipo di fusibile Fuse type			Attacchi laterali singoli _Single side connections			
		NFC	DIN	BS	NFC	DIN	BS	
125A	22x58	NH 00	A4	3	12022	12042	12061	
				4	12032	12052	12071	
	-	NH 0	-	3	-	12043	-	
				4	-	12053	-	
160A	-	NH 00	A4	3	-	12044	12062	
				4	-	12054	12072	
	-	NH 0	-	3	-	12045	-	
				4	-	12055	-	
VC3F	250A	-	NH1	B1 ÷ B3	3	-	13042	13062
				4	-	13052	13072	
VC4F	400A	-	NH 2	B1 ÷ B4	3	-	14023	14043
				4	-	14033	14053	
VC5F	630A	-	NH 3	C1 ÷ C2	3	-	15020	15040
				4	-	15030	15050	

Altre esecuzioni disponibili su richiesta  
\_Other executions available on request

SERIE\_SERIES VCF

VC2F

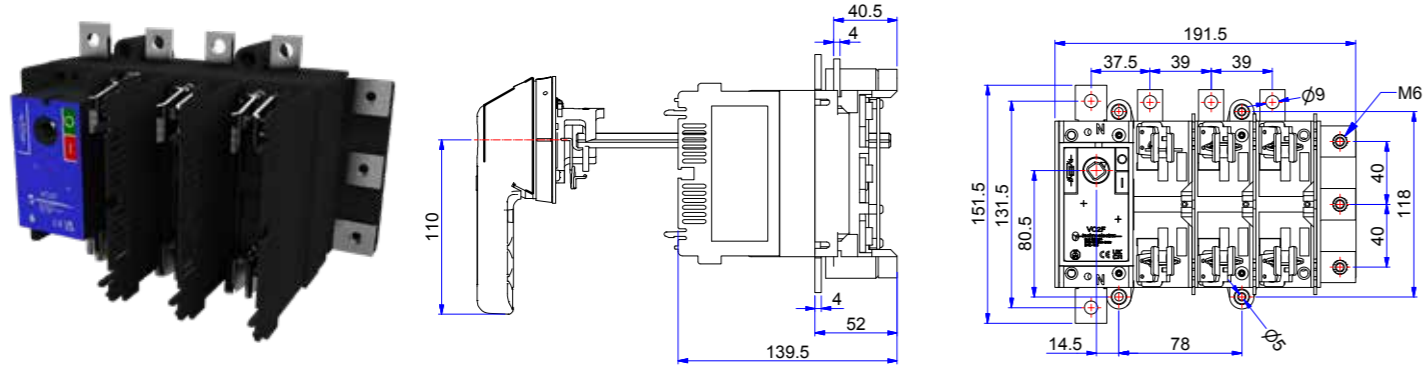

Legenda \_caption

VC2F 125 ÷ 160 A

P		C	H
min	max		
177,5	280,5	68,5	P-C

C= costante\_ constant

Foratura portella \_Door drilling

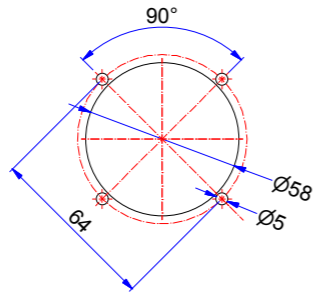

VC4F

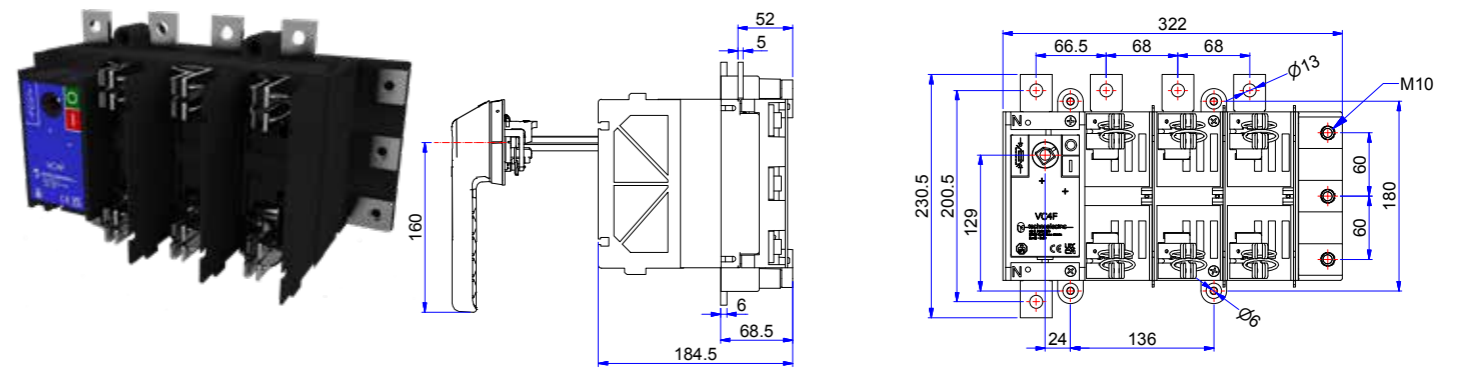

Legenda \_caption

VC4F 315 ÷ 400 A

P		C	H
min	max		
225	306,5	96	P-C

C= costante\_ constant

Foratura portella \_Door drilling

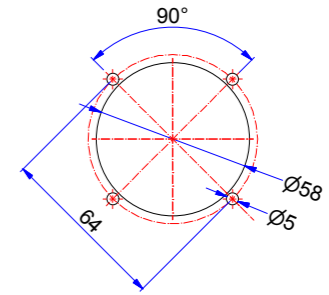

VC3F

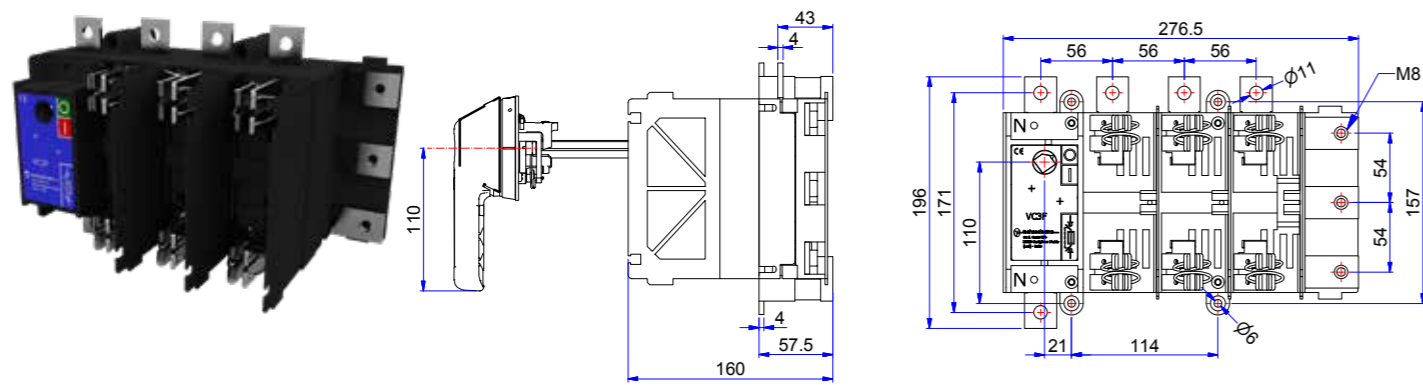

Legenda \_caption

VC3F 200 ÷ 250 A

P		C	H
min	max		
209	300,5	71,5	P-C

C= costante\_ constant

Foratura portella \_Door drilling

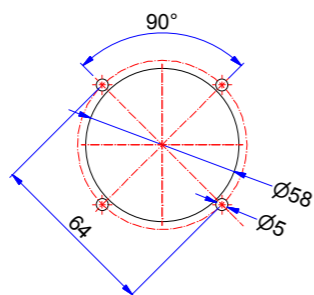

VC5F

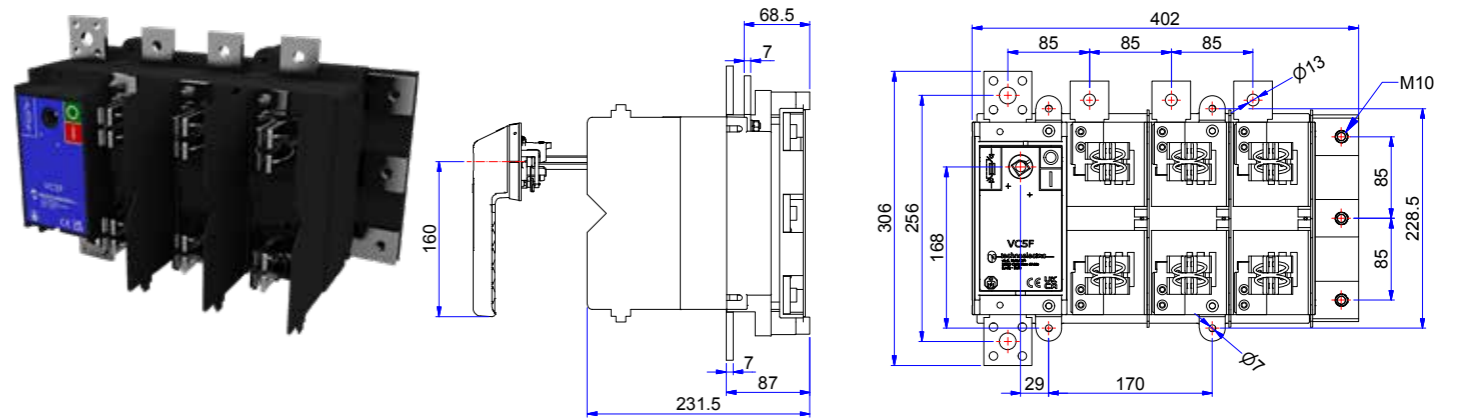

Legenda \_caption

VC5F 630 A

P		C	H
min	max		
317	327		P-C

C= costante\_ constant

Foratura portella \_Door drilling

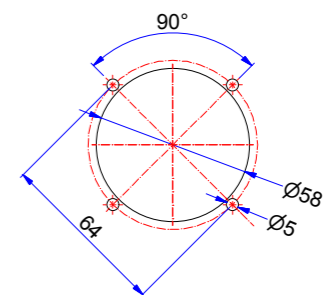

**VISUALCOMPACT Fu | Ultra rapidi**

**GENERALITÀ**

Gli interruttori della serie VISUALCOMPACT Fu sono una serie di interruttori di manovra sezionatori con porta fusibili del tipo T/80, T/110\* e BK50. L'impiego di questa serie consente la manovra in apertura e richiusura sotto carico e il sezionamento di sicurezza. L'abbinamento con gli specifici fusibili, consente la protezione di apparati elettronici di potenza (semi-conduttori, raddrizzatori, inverter ecc.).

**NOTE TECNICHE**

Le tipologie di fusibili da noi indicate, DIN 43653 T/80 e T/110, BK50 rappresentano la migliore associazione tecnica tra il nostro interruttore e il fusibile ultra rapido. Per ulteriori esigenze di abbinamento o di portate maggiori prego consultarci.

\*Fusibili T/110 a richiesta.

**VISUALCOMPACT Fu | Ultra rapid**

**GENERALITIES**

The VISUALCOMPACT Fu series is a range of switch disconnectors fuse with fuse holders of T/80, T/110\* and BK50 type. The use of this series allows making and breaking operations under load and safety disconnection. With suitable fuses, it allows the protection of power electronic devices (semiconductors, rectifiers, inverters etc.).

**TECHNICAL NOTES**

BK50, T/80 and T/110 DIN 43653 types of fuses represent the best technical combination between Visualcompact Fu switches and ultra rapid fuses. For other types of combinations or higher current please contact us.

\*Fuses T/110 on demand.

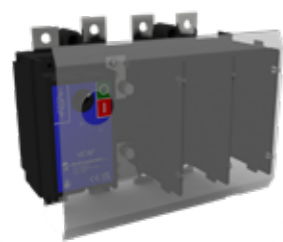

Tipo _type	Corrente nominale _rated current	POLI _POLES	Tipo fusibile _fuse type	Senza maniglia _without handle
			DIN 43653	Codice _codes
<b>VC2Fu</b>	40A	3	T80-00	12041U
		4	T80-00	12051U
	80A	3	T80-00	12042U
		4	T80-00	12052U
90A	3	T80-00	12043U	
	4	T80-00	12053U	
<b>VC3Fu</b>	100A	3	T80-00	12044U
		4	T80-00	12054U
	140A	3	T80-00	13041U
		4	T80-00	13051U
170A	3	T80-00	13042U	
	4	T80-00	13052U	
<b>VC4Fu</b>	260A	3	T80-00	14022U
		4	T80-00	14032U
	290A	3	T80-00	14023U
<b>VC5Fu</b>	450A	3	BK50 - 2	15020U
		4	BK50 - 2	15030U
	500A	3	BK50 - 2	15021U
		4	BK50 - 2	15031U

Tipo _type	Maniglia diretta _direct handle	Maniglia blocco porta _door interlock handle
VC2Fu	18081	18001
VC3Fu	18083	18003
VC4Fu	18083	18003
VC5Fu	18084	18005

Possibilità di esecuzione per EO con fusibili.  
\_Version for EO with fuses available.

**VC2Fu**

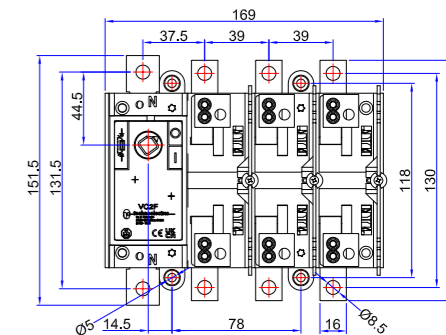
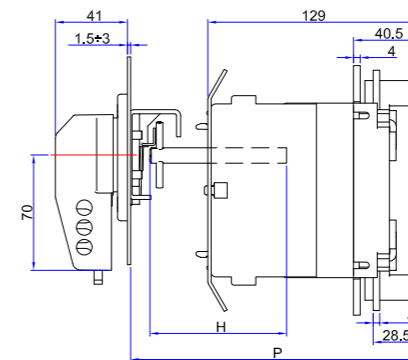

Legenda \_caption

VC2Fu 40 ÷ 100 A

P		C	H
min	max		
177,5	268,5	68,5	P-C

C= costante \_constant

Foratura portella \_Door drilling

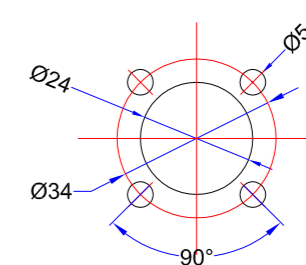

**VC3Fu**

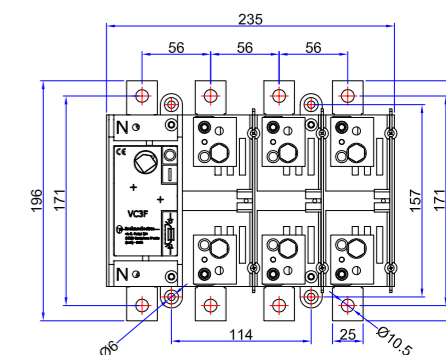
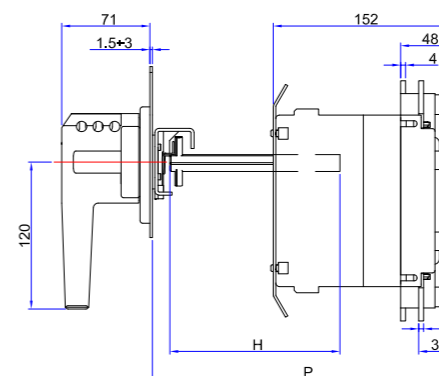
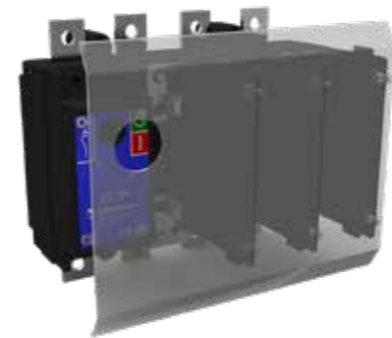

Legenda \_caption

VC3Fu 140 ÷ 170 A

P		C	H
min	max		
187	280,5	71,5	P-C

C= costante \_constant

Foratura portella \_Door drilling

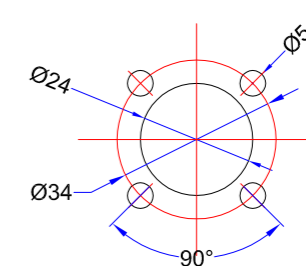

**VC4Fu**

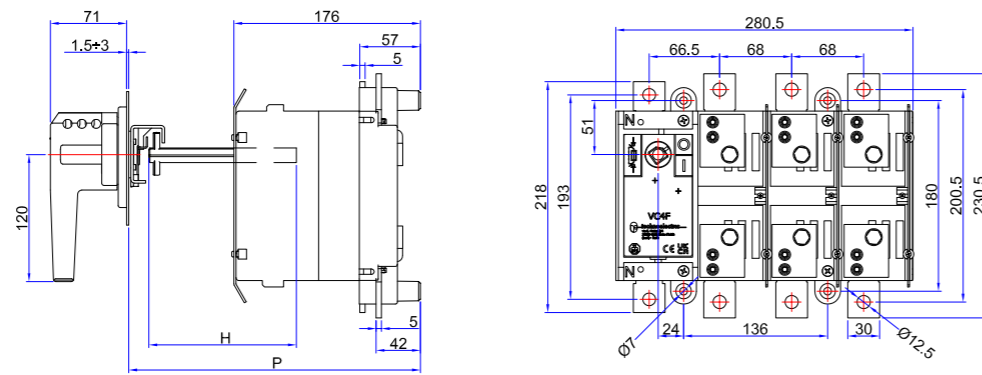

Legenda \_caption

VC4Fu 260 ÷ 290 A

P		C	H
min	max		
215	296	96	P-C

C= costante\_ constant

Foratura portella \_Door drilling

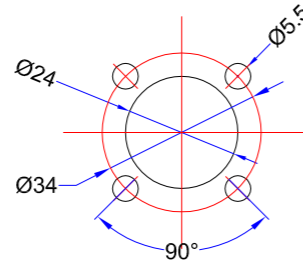

**VC5Fu**

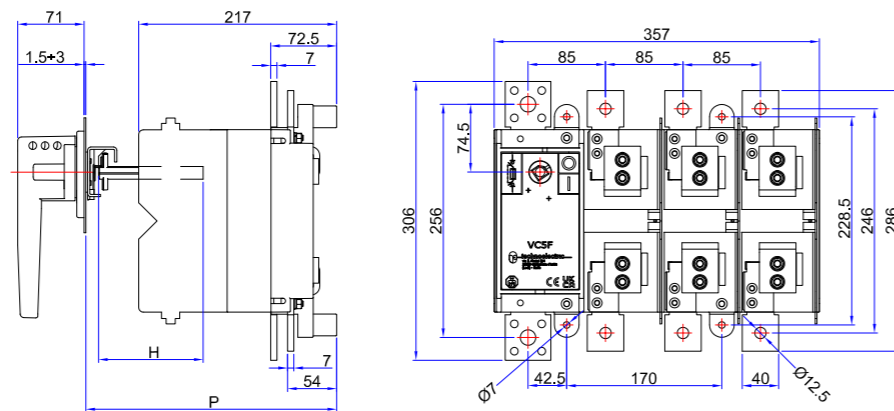
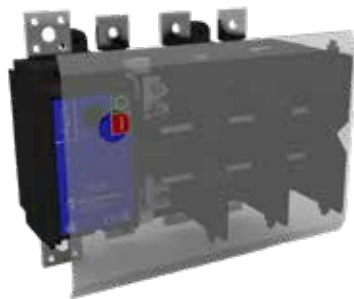

Foratura portella \_Door drilling

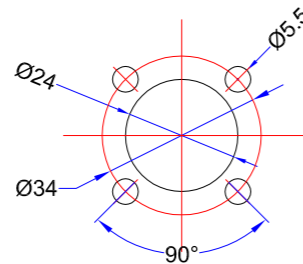

Legenda \_caption

VC5Fu 450 ÷ 500 A

P		C	H
min	max		
257	320	120	P-C

C= costante\_ constant

**FBA visualcompact con dispositivo di apertura**

**FBA visualcompact with tripping device**

**GENERALITÀ**

Gli interruttori della serie VISUALCOMPACT FBA sono 3 - 4 poli con comando manuale, corredati di un comando di apertura locale per mezzo di maniglia a distanza tramite bobina a lancio di corrente alimentata dall'esterno.

**GENERALITIES**

Switch disconnectors VISUALCOMPACT FBA are 3 - 4 poles manually operated and are switches supplied with a remote tripping device by means of a current shot coil.



Tipo _type	Corrente nominale _rated current	POLI _POLES	24 V c.c. \ DC	48 V c.c. \ DC	110 V c.c. \ DC	110 V c.a. \ AC	220 V c.a. \ AC
<b>VC4F BA</b>	250A	3	14021B	14021B1	14021B2	14021B3	14021B4
		4	14031B1	14031B1	14031B2	14031B3	14031B4
	315A	3	14022B	14022B1	14022B2	14022B3	14022B4
		4	14032B	14032B1	14032B2	14032B3	14032B4
	400A	3	14023B	14023B1	14023B2	14023B3	14023B4
		4	14033B	14033B1	14033B2	14033B3	14033B4
<b>VC5F BA</b>	630A DIN	3	15020B	15020B1	15020B2	15020B3	15020B4
		4	15030B	15030B1	15030B2	15030B3	15030B4
	630A BS	3	15040B	15040B1	15040B2	15040B3	15040B4
		4	15050B	15050B1	15050B2	15050B3	15050B4
	800A DIN	3	15022B	15022B1	15022B2	15022B3	15022B4
		4	15032B	15032B1	15032B2	15032B3	15032B4
	800A BS	3	15041B	15041B1	15041B2	15041B3	15041B4
		4	15051B	15051B1	15051B2	15051B3	15051B4

Versione per fusibile BS a richiesta  
\_BS version available on request

I codici sopracitati non comprendono la maniglia di manovra e la prolunga albero di comando  
\_the below codes do not include door interlock handle and extension shaft



VC4F BA

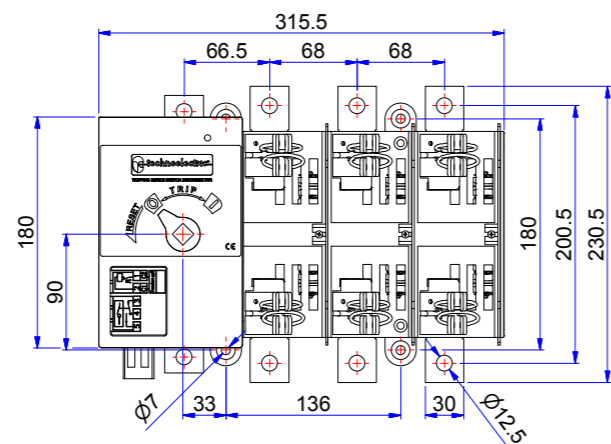

Foratura portella \_Door drilling

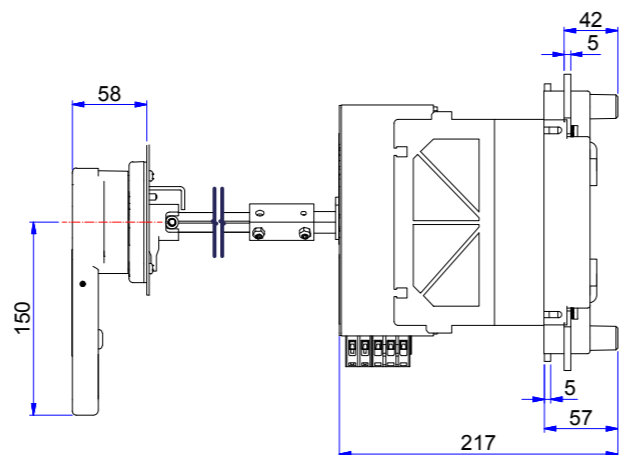
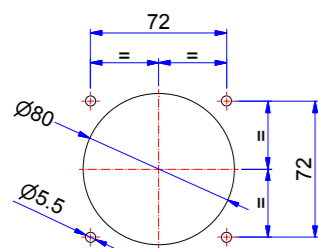

SCHEMA MORSETTIERA BA  
\_terminal board diagram BA

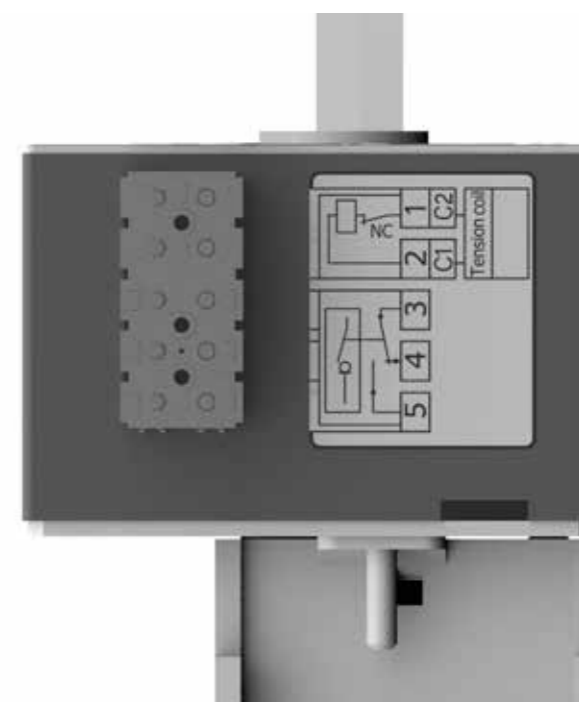

VC5F BA

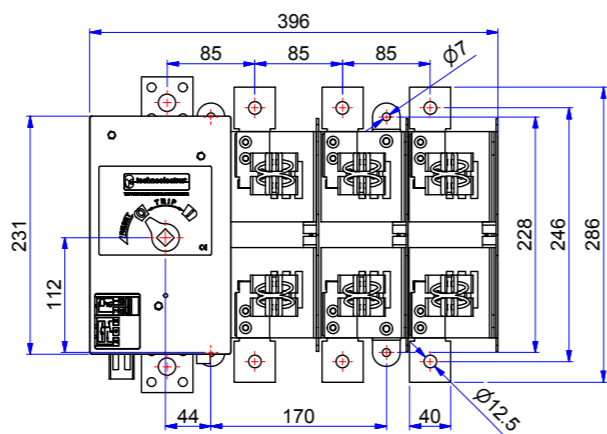

Foratura portella \_Door drilling

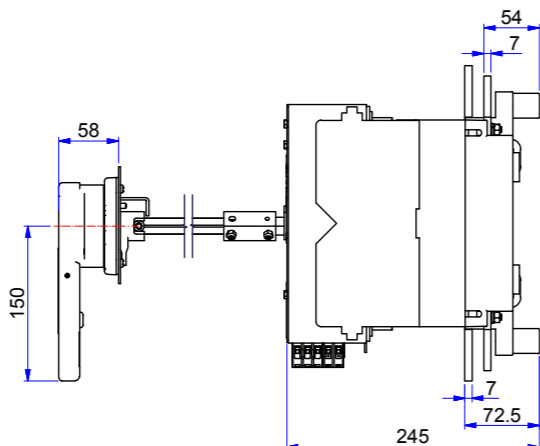
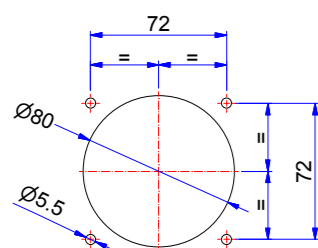

## SERIE\_SERIES VCF

### VISUALCOMPACT VCF - MS

#### Interruttori di manovra a comando motorizzato

#### GENERALITÀ

La nuova serie VISUALCOMPACT F MS consta di interruttori-sezionatori motorizzati a 3 - 4 poli con porta fusibili. Assicura, attraverso un comando a distanza, manovre di apertura e chiusura sotto carico in sistemi e impianti di bassa tensione.

#### CARATTERISTICHE GENERALI

Le caratteristiche tecniche degli interruttori di manovra sezionatori impiegati nei VISUALCOMPACT F MS sono rispondenti a quanto riportato nei capitoli riguardanti la serie VISUALCOMPACT F.

- Manovra manuale d'emergenza (0-1 e 1-0) con maniglia a corredo
- Blocco meccanico di sicurezza lucchettabile, in posizione 0 interdice la manovra elettrica e manuale
- Visualizzazione meccanica e luminosa (led) della pos.0,1
- Segnalazione esterna della posizione tramite contatto AUX (vedi morsettiera)
- Tempo di manovra (0-1 o 1-0) 1,5 sec
- Alimentazione aux. 12/24 VCC 110/220/380 VCA
- Temperatura ambiente di funzionamento - 20°C + 40°C

#### CONFORMITÀ ALLE NORME

IEC 60947-1 IEC 60947-3 | UNI EN 60947-1 | UNI EN 60947-3  
VDE 0660 Teil 107 | EAC



Schema morsettiera MS  
\_MS terminal block diagram

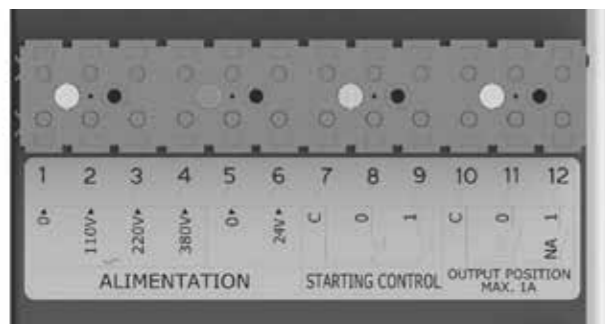

### \_VISUALCOMPACT VCF - MS Motorized load break switches

#### GENERALITIES

The new series VISUALCOMPACT F MS are 3 - 4 poles load break switches and fuse load break switches. They allow making and breaking operations of low voltage system under load by control.

#### \_GENERAL CHARACTERISTICS

The technical characteristics of the load break switches used in the VISUALCOMPACT F MS are correspondent to as shown in the chapter of VISUALCOMPACT F series.

- Emergency manual operation (0-1 and 1-0) by means of equipped handle
- Emergency padlockable mechanical block of electrical and manual operation in 0 position
- Mechanical and illuminated indication (led) of position 0,1
- External input of position segnalization by auxiliary contacts (see terminal board diagram)
- 0-1 or 1-0 operating time 1,5 sec.
- Supply voltages 12/24V DC, 110/220/380V AC
- Working ambient temperature from - 20°C + 40°C

#### \_CERTIFICATES AND APPROVALS

IEC 60947-1 IEC 60947-3 | UNI EN 60947-1 | UNI EN 60947-3  
VDE 0660 Teil 107 | EAC

Tipo _type	Corrente nominale _rated current	POLI _POLES	Codice _code
<b>VC2F MS</b>	100A	3	12041MS
		4	12051MS
	125A	3	12042MS
		4	12052MS
<b>VC3F MS</b>	160A	3	12043MS
		4	12053MS
	200A	3	13041MS
		4	13051MS
<b>VC4F MS</b>	250A	3	13042MS
		4	13052MS
	315A	3	14022MS
		4	14032MS
<b>VC5F MS</b>	400A	3	14023MS
		4	14033MS
	630A	3	15020MS
		4	15030MS
800A	3	15041MS	
	4	15051MS	

### VC2F MS

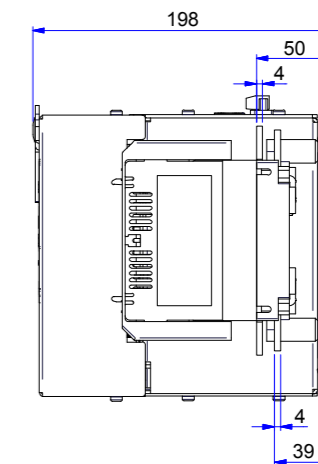
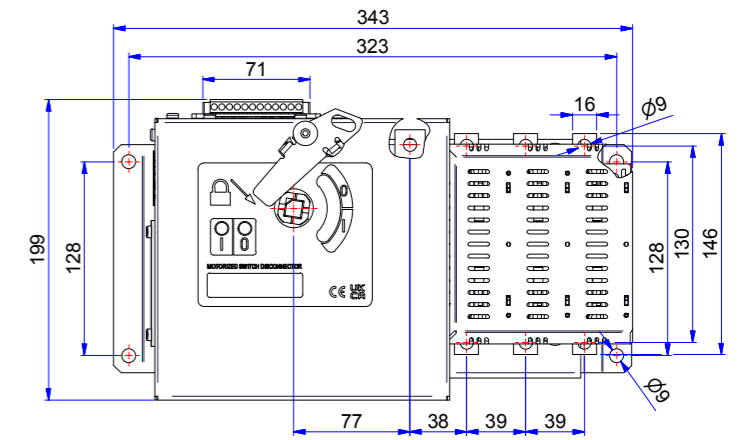

### VC3F MS

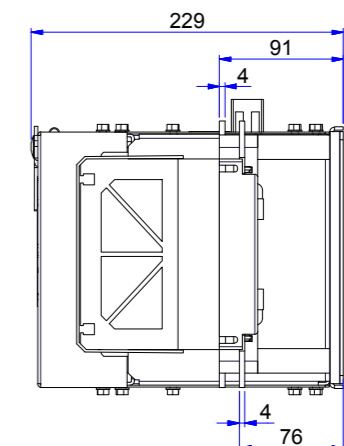
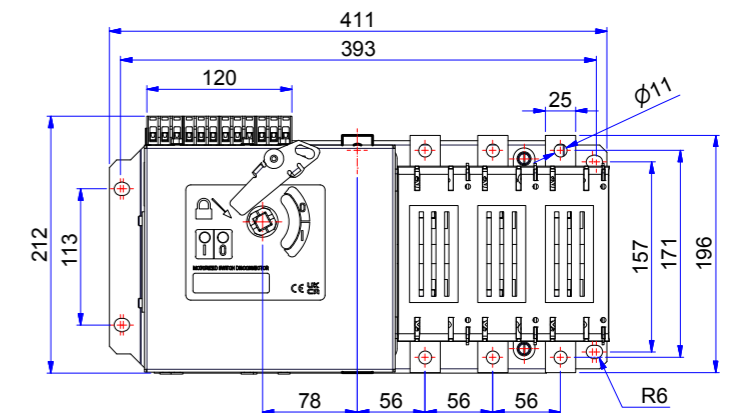

**VC4F MS**

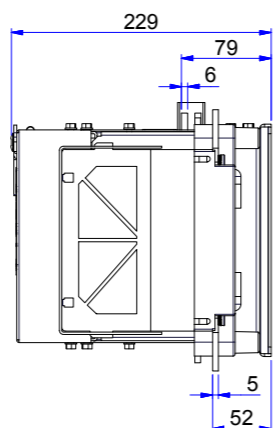
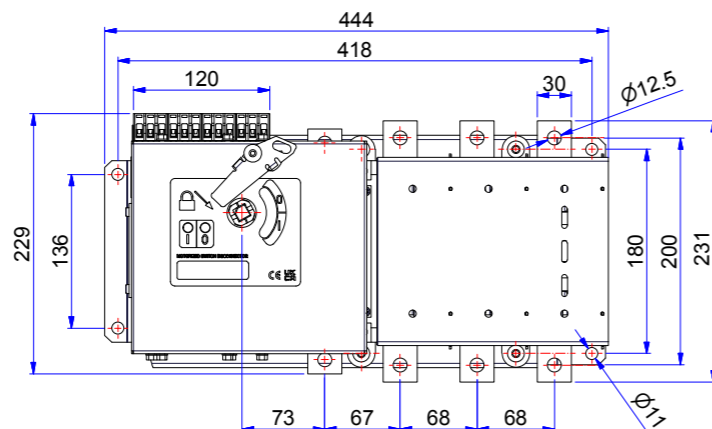

**VC5F MS**

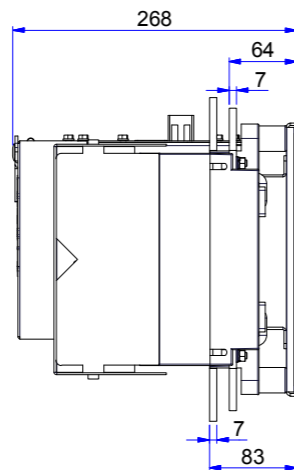
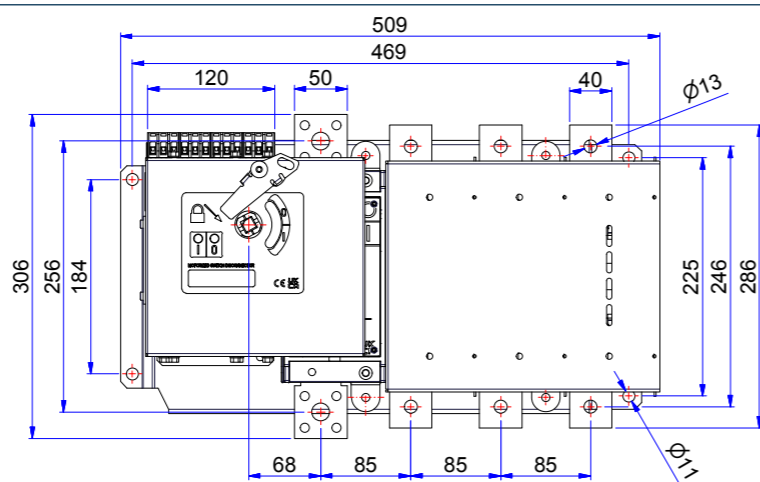

**EOF**



Tipo _type	Corrente nominale _rated current	Tipo fusibile _fuse type DIN	POLI _POLES	Con maniglia blocco _with door interlock handle	Senza maniglia _without handle
				CODICE _CODES	CODICE _CODES
<b>EO1F</b>	32 A	NH 00	6	110406	110406SM
			8	110506	110506SM
	45A	NH 00	6	110416	110416SM
			8	110516	110516SM
	63A	NH 00	6	110426	110426SM
			8	110526	110526SM
	80A	NH 00	6	110436	110436SM
			8	110536	110536SM
	100A	NH 00	6	110446	110446SM
			8	110546	110546SM
	100A	NH 00	6	120416	120416SM
			8	120516	120516SM
125A	NH 00	6	120426	120426SM	
		8	120526	120526SM	
<b>EO2F</b>	160A	NH 00	6	120436	120436SM
			8	120536	120536SM
125A	NH 0	6	120446	120446SM	
		8	120546	120546SM	
160A	NH 0	6	120456	120456SM	
		8	120556	120556SM	
<b>EO3F</b>	200A	NH 1	6	130416	130416SM
			8	130516	130516SM
	250A	NH 1	6	130426	130426SM
			8	130526	130526SM
<b>EO4F</b>	315A	NH 2	6	140226	140226SM
			8	140326	140326SM
	400A	NH 2	6	140236	140236SM
			8	140336	140336SM
<b>EO5F</b>	630A	NH 3	6	150206	150206SM
			8	150306	150306SM
	800A	NH 3	6	150226	150226SM
			8	150326	150326SM

EO1F

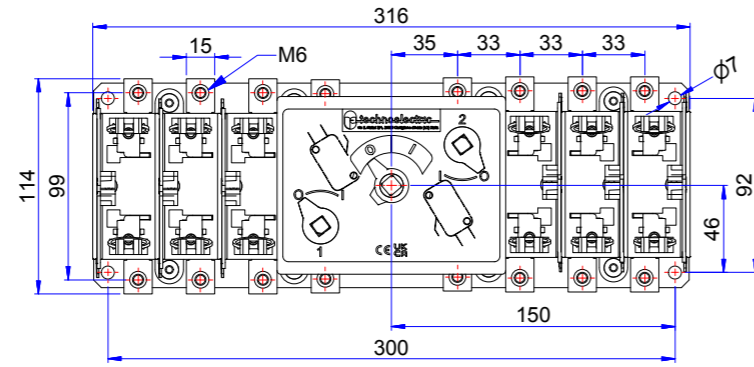

Foratura portella \_Door drilling

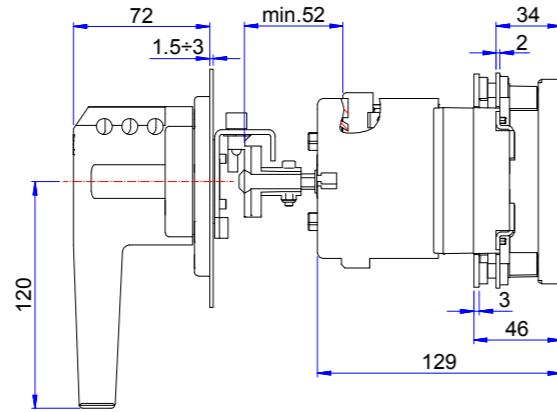
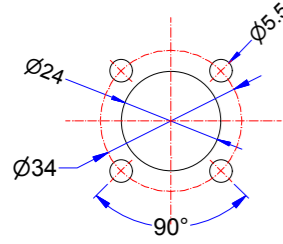

EO3F

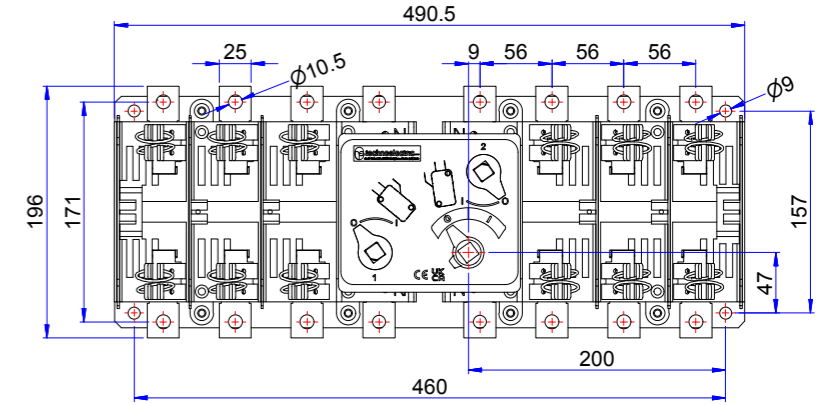

Foratura portella \_Door drilling

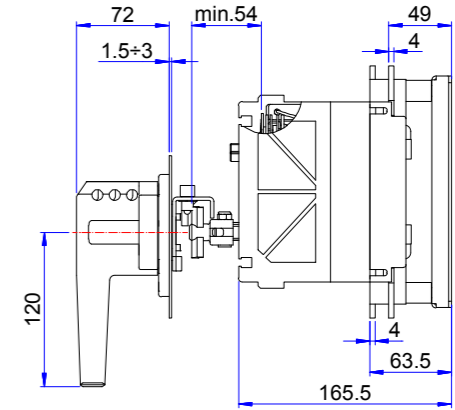
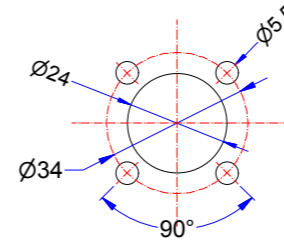

EO2F

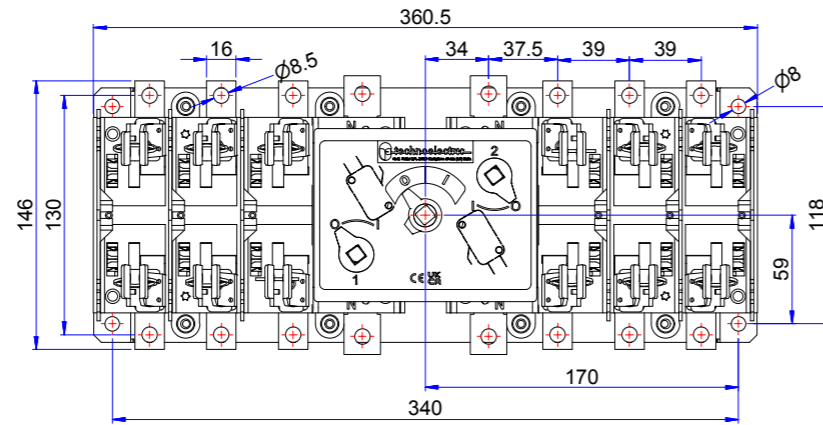

Foratura portella \_Door drilling

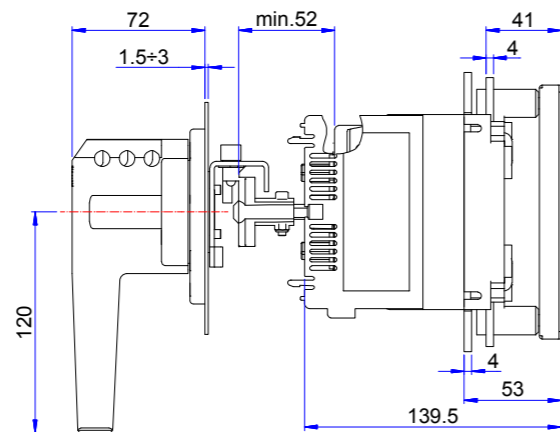
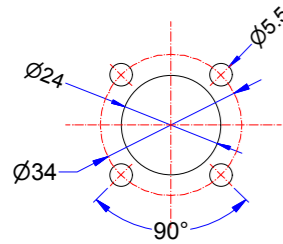

EO4F

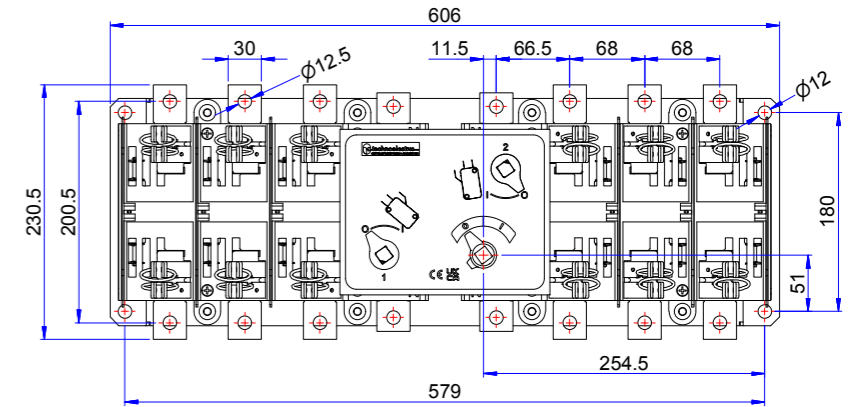

Foratura portella \_Door drilling

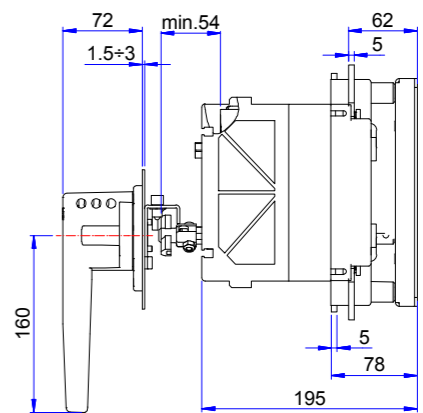
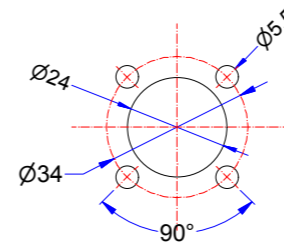



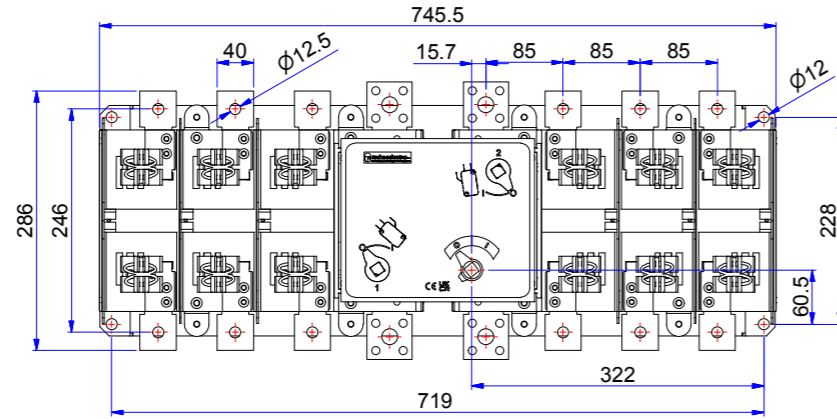

Foratura portella \_Door drilling

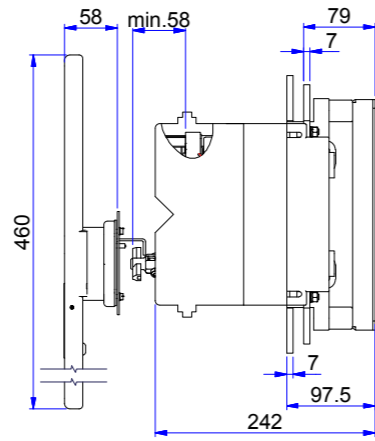
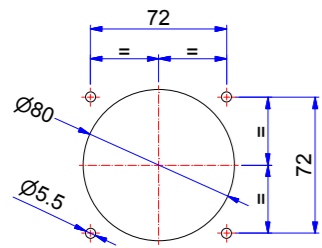

**MANIGLIA BLOCCO PORTA NERA**  
\_black door interlock handle

Tipo_type	Poli_poles	VC1F	VC2F	VC3F	VC4F	VC5F
Codice_code	3   4	18001	18001	18003	18003	18005   18007
Codice_code	6   8	18003	18003	18005	18005	18830   18844

**18001**

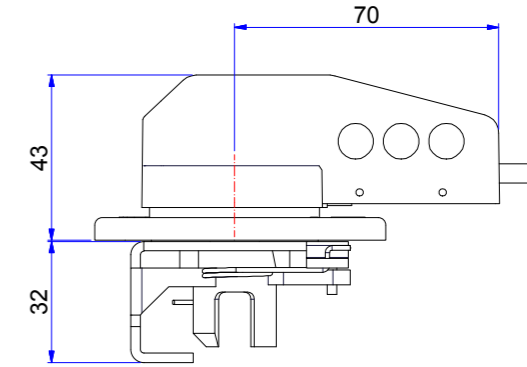

Foratura portella \_Door drilling

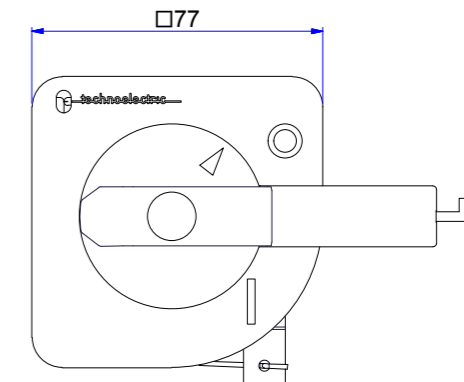
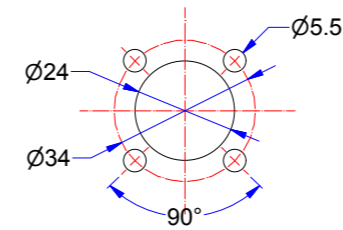

**18003**

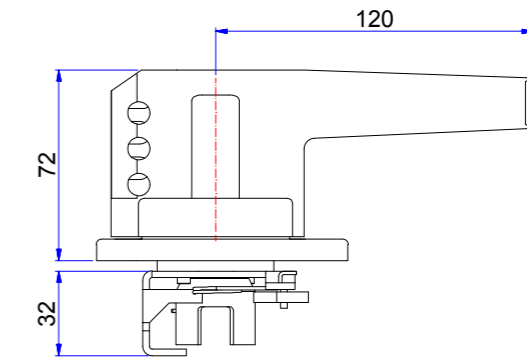

Foratura portella \_Door drilling

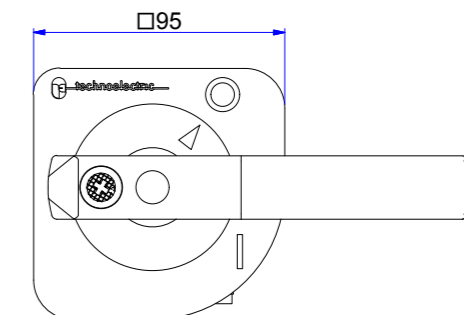
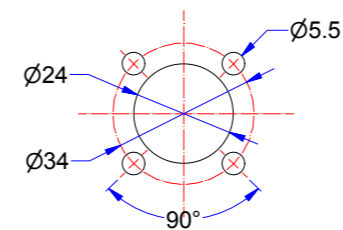

18005

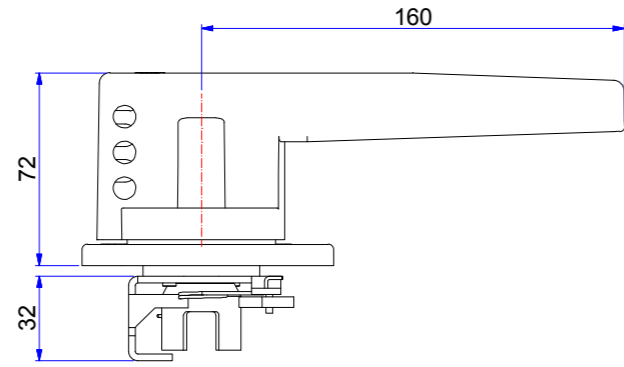

Foratura portella \_Door drilling

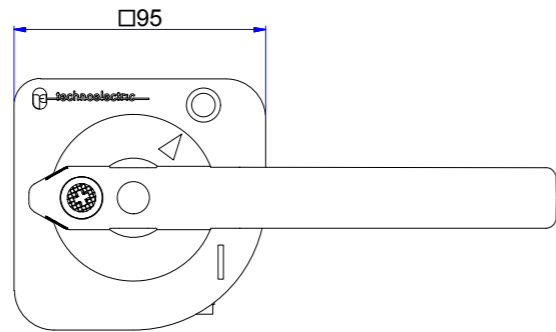
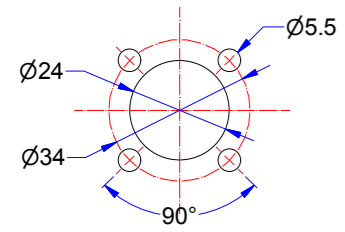

18830

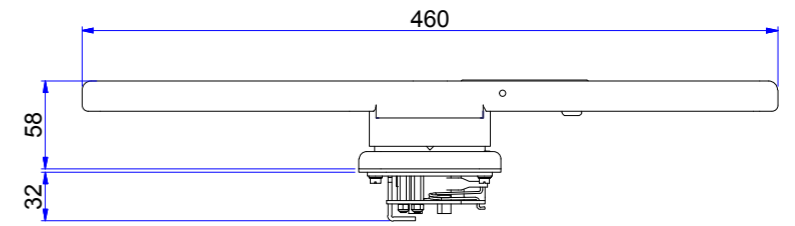

Foratura portella \_Door drilling

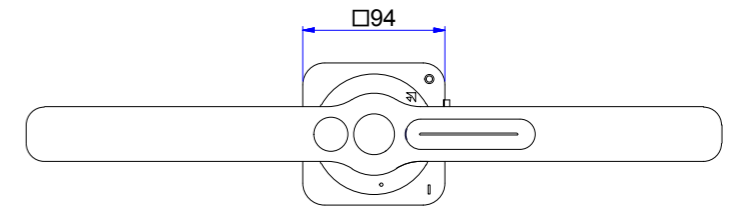
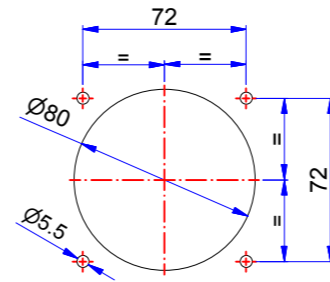

18007

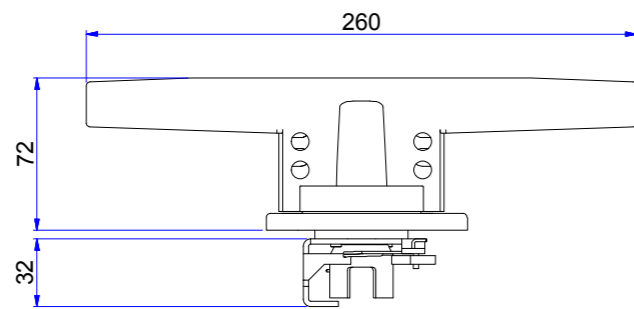

Foratura portella \_Door drilling

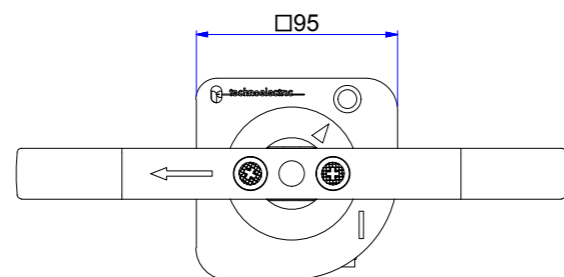
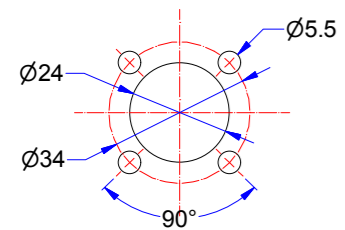

18844

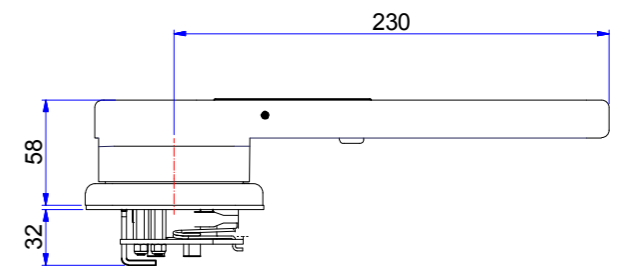

Foratura portella \_Door drilling

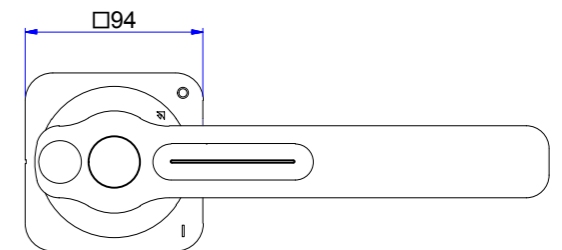
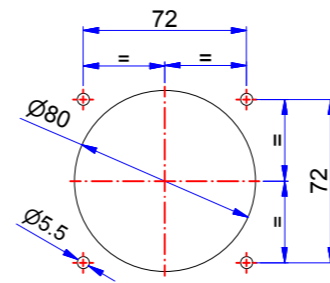

**MANIGLIA BLOCCO PORTA D'EMERGENZA**

**\_red\yellow door interlock handle**

Tipo_type	Poli_poles	VC1F	VC2F	VC3F	VC4F	VC5F
Codice_code	3   4	18002	18002	18004	18004	18006   18008
Codice_code	6   8	18004	1804	18006	18006	18831   18847

**18002**

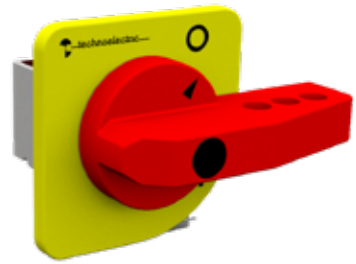

Foratura portella \_Door drilling

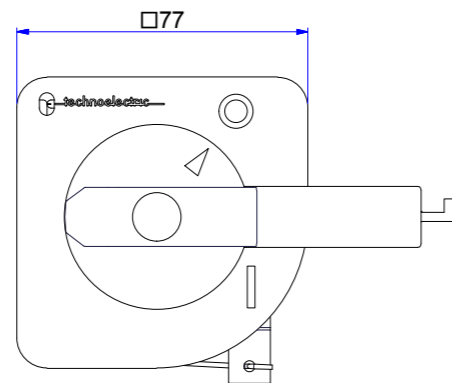
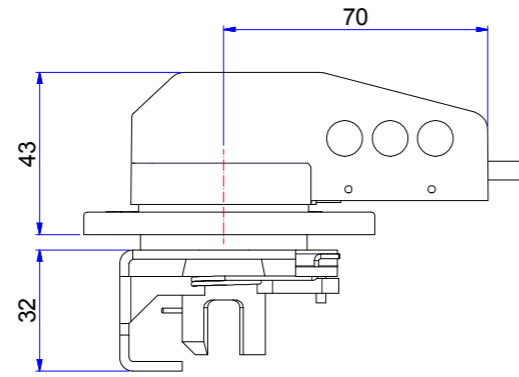
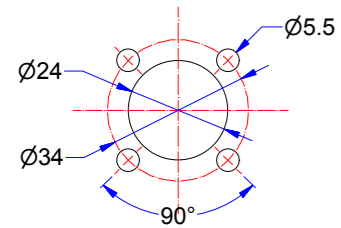

**18006**

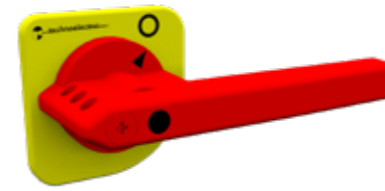

Foratura portella \_Door drilling

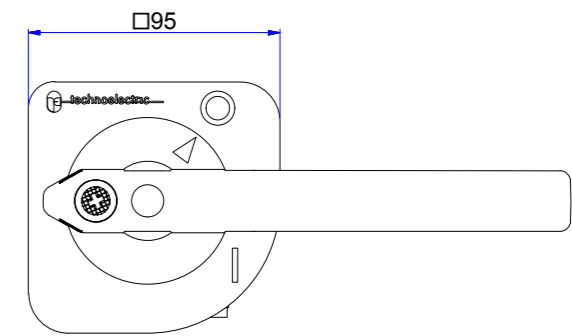
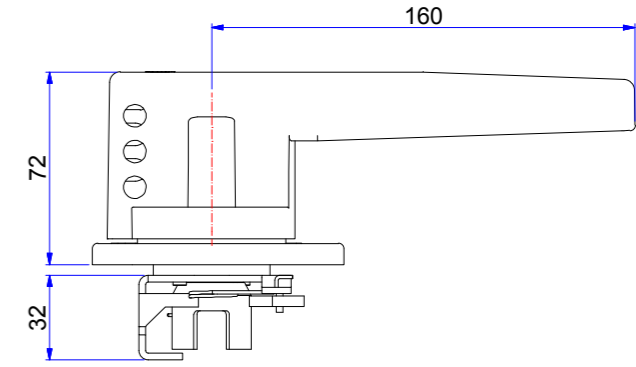
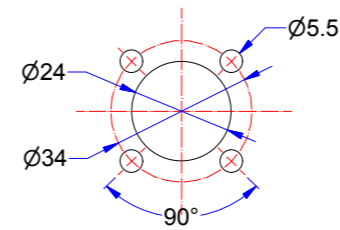

**18004**



Foratura portella \_Door drilling

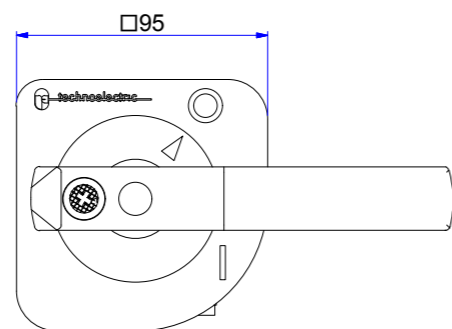
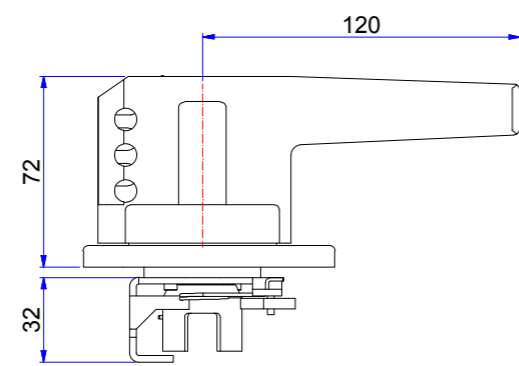
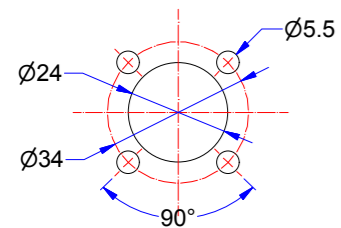

**18008**



Foratura portella \_Door drilling

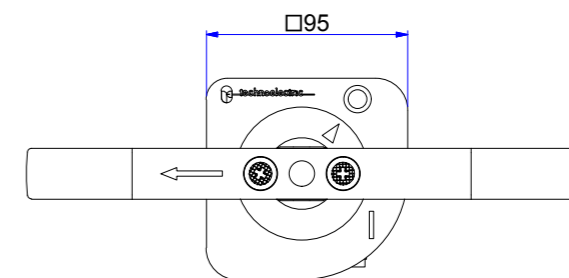
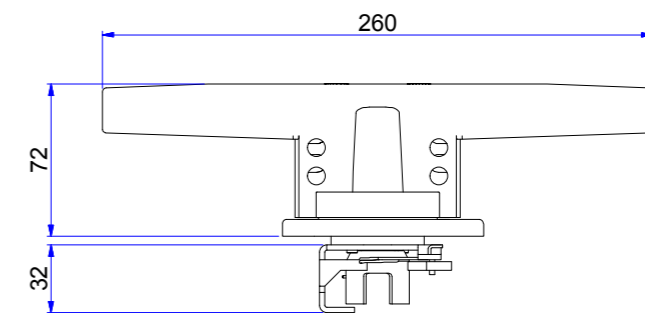
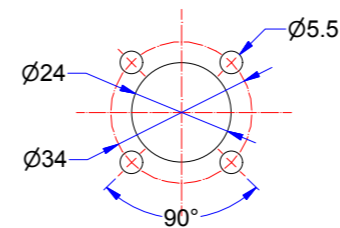

18831

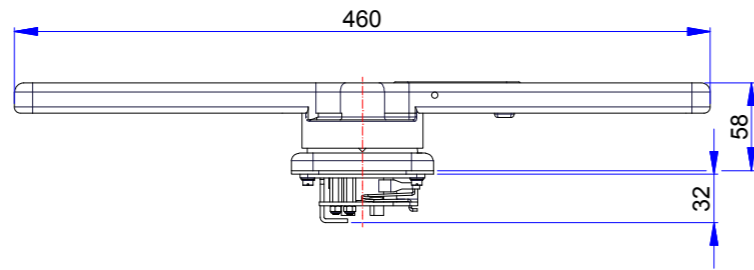

Foratura portella \_Door drilling

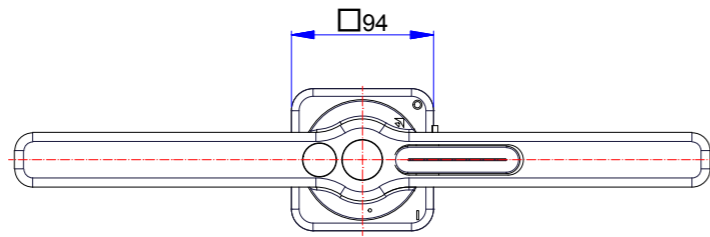
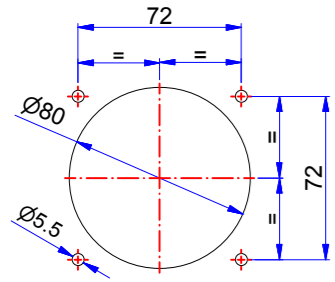

**ALBERO COMANDO**  
\_shaft



200 mm

Tipo _type	VC1F	VC2F	VC3F	VC4F	VC5F
Codice _code	18201	18201	18207	18207	18207

300 mm

TiFo _tyFe	VC1F	VC2F	VC3F	VC4F	VC5F
Codice _code	18202	18202	18208	18208	18208

400 mm

Tipo _type	VC1F	VC2F	VC3F	VC4F	VC5F
Codice _code	18203	18203	18209	18209	18209

18847

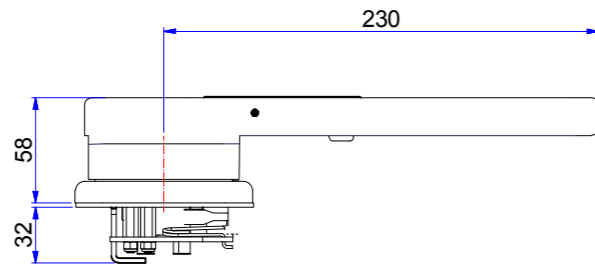

Foratura portella \_Door drilling

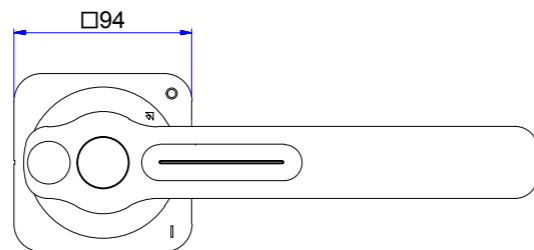
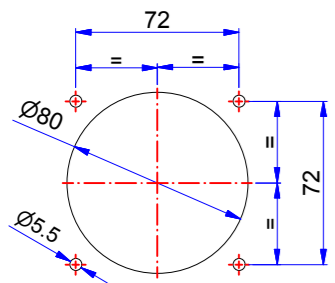

**PROLUNGA ALBERO**  
\_extension shaft



100 mm

Tipo _type	EOF 1 2	EOF 3 4 5 VCF BA 4 5
Codice _code	18030	18032

200 mm

TiFo _tyFe	EOF 1 2	EOF 3 4 5 VCF BA 4 5
Codice _code	18033	18035

300 mm

Tipo _type	EOF 1 2	EOF 3 4 5 VCF BA 4 5
Codice _code	18036	18038



SERIE\_SERIES VCF  
**MANIGLIA DIRETTA**  
 \_direct handle

Tipo_type	EO1F	EO2F	EO3F	EO4F	EO5F
Codice _code	18594	18595	18597	18598	18599

Fornita completa di due schermi protezione fusibili. Versione lucchettabile fornibile a richiesta  
 \_With two fuses cover. Padlockable version on request

**18594**

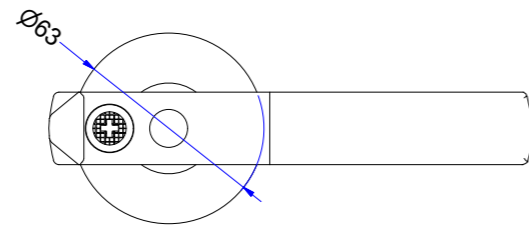
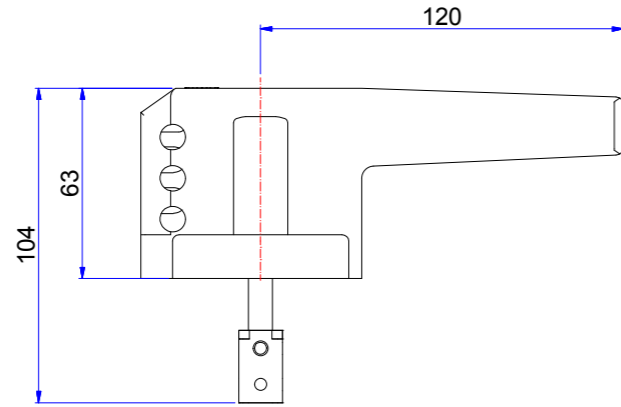

**18597**

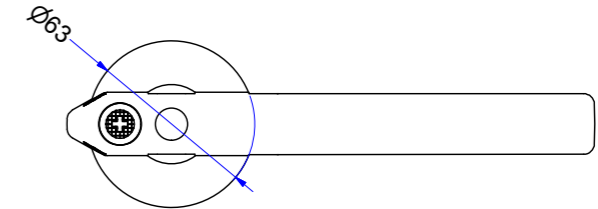
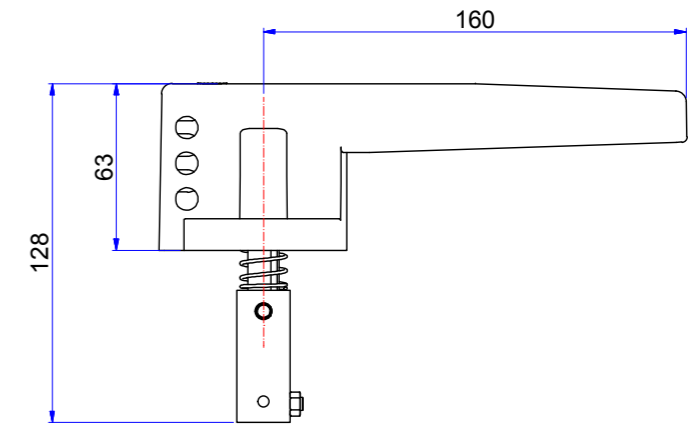

**18595**

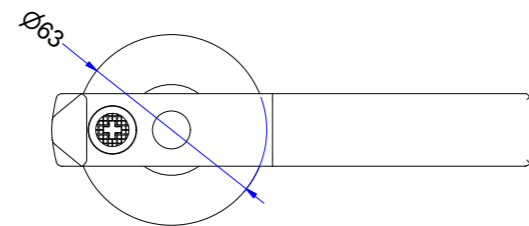
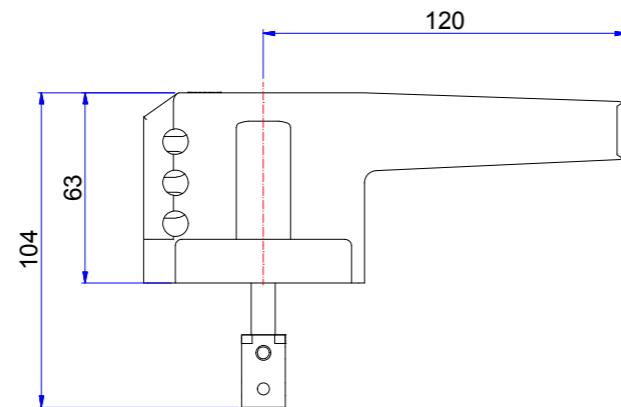

**18598**

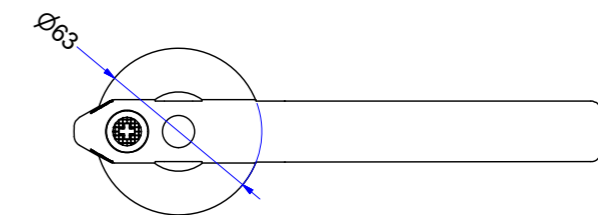
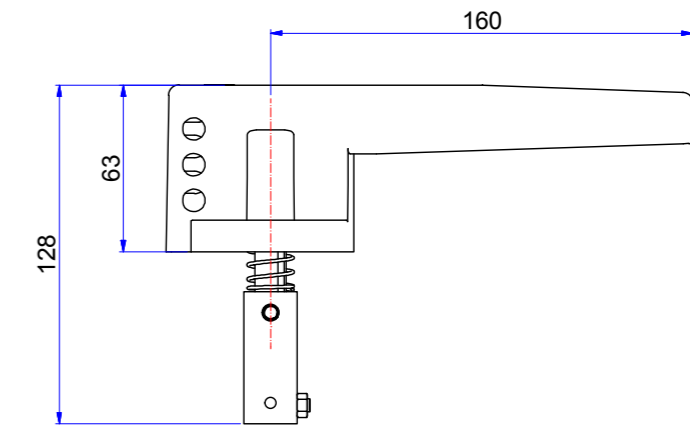

18599

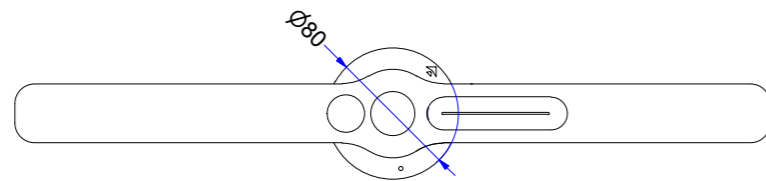
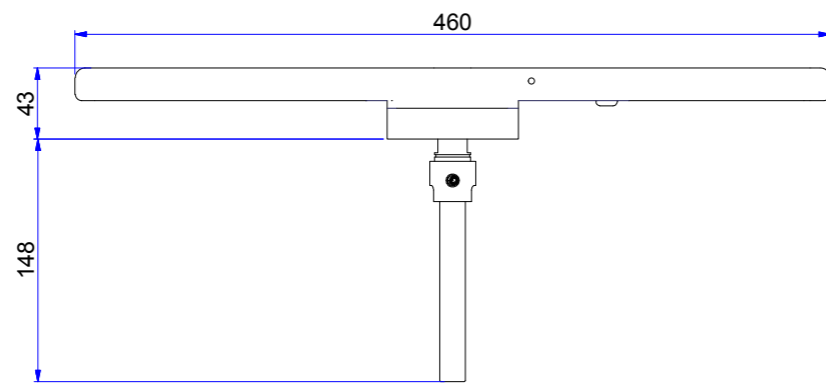
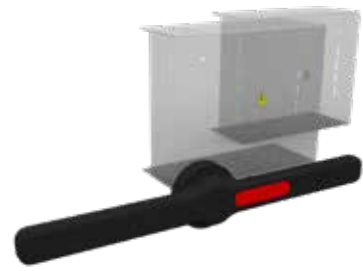

**BLOCCO LUCCHETTO PER MANIGLIA DIRETTA**  
\_padlock for direct handle

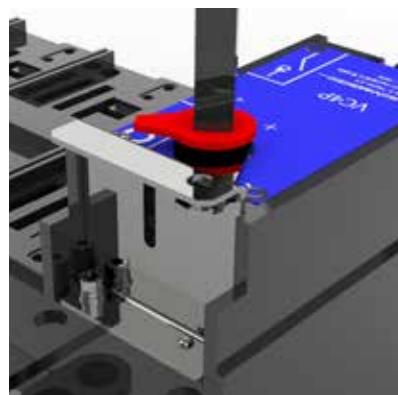

Tipo_type	VC1F	VC2F	VC3F	VC4F	VC5F
Codice_code	18240	18241	18242	18243	18244

**MANIGLIA BLOCCO PORTA CON BLOCCO CHIAVE**  
\_door interlock handle with key lock

Tipo_type	VC1F	VC2F	VC3F	VC4F	VC5F
Codice_code	18100	18100	18100	18100	18102   18104

18100



Foratura portella \_Door drilling

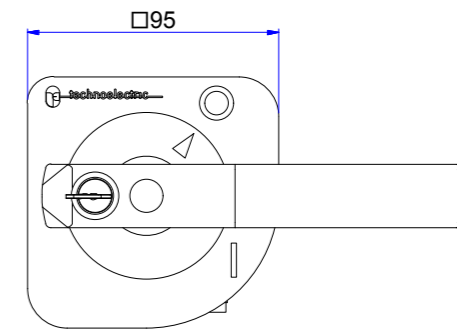
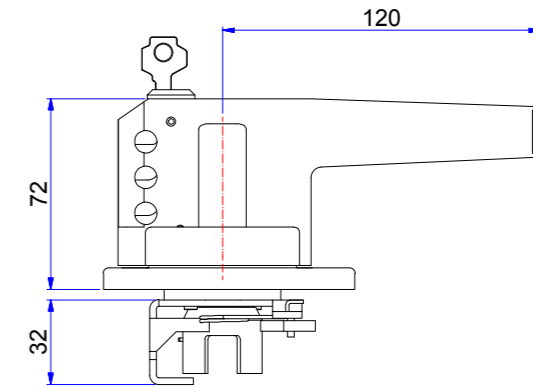
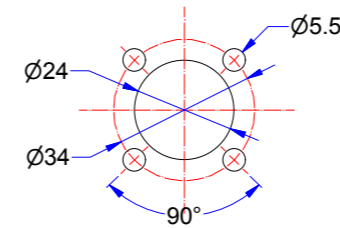

18102



Foratura portella \_Door drilling

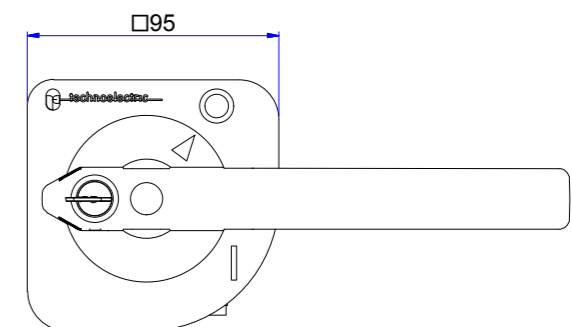
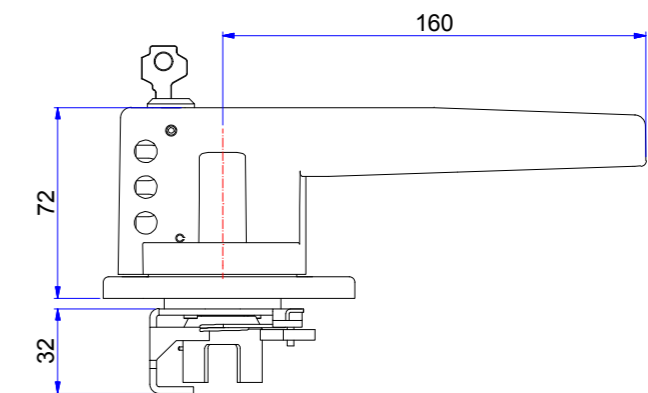
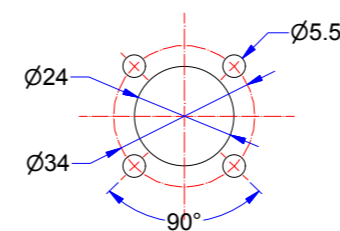

18104

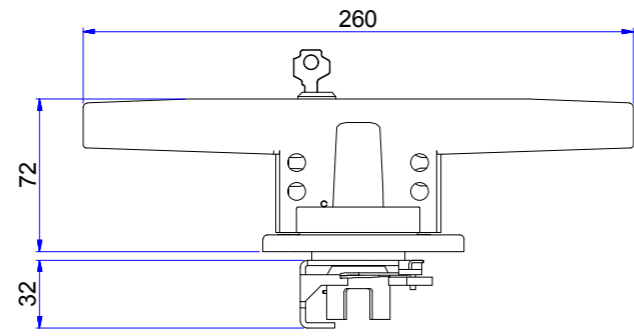

Foratura portella \_Door drilling

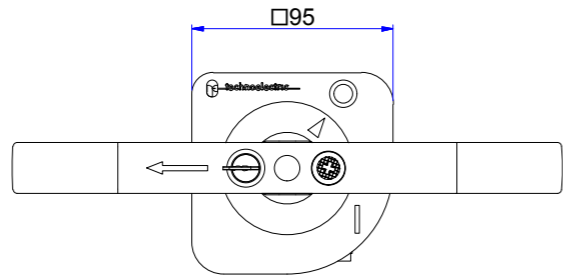
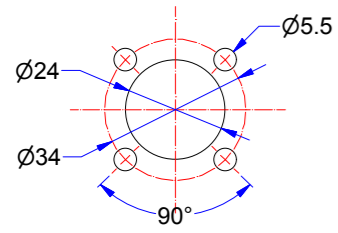

**MANIGLIA BLOCCO PORTA NERA  
CON DISPOSITIVO DI SBLOCCO CON ATTREZZO SPECIALE**  
**\_black door interlock handle with defeater mechanism (special tool)**

Tipo_type	VC1F	VC2F	VC3F	VC4F	VC5F
Codice_code	18220	18220	18222	18222	18224   18832 18226   18850

18220

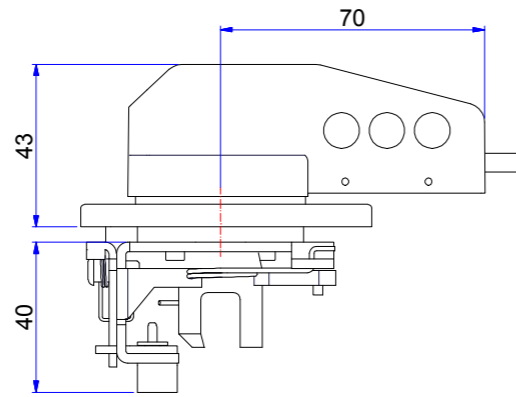

Foratura portella \_Door drilling

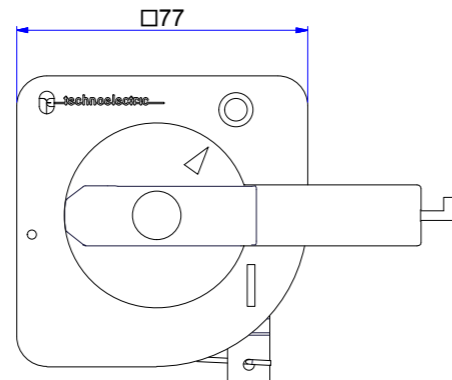
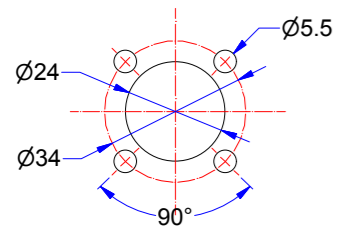

18222

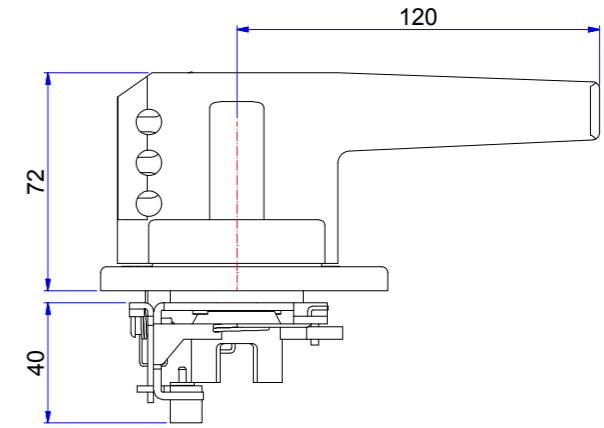

Foratura portella \_Door drilling

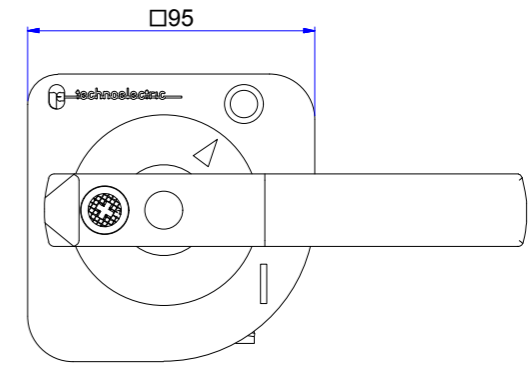
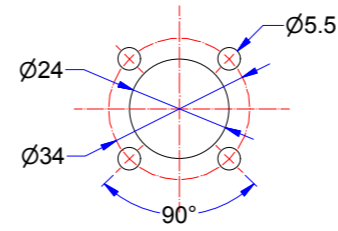

18224

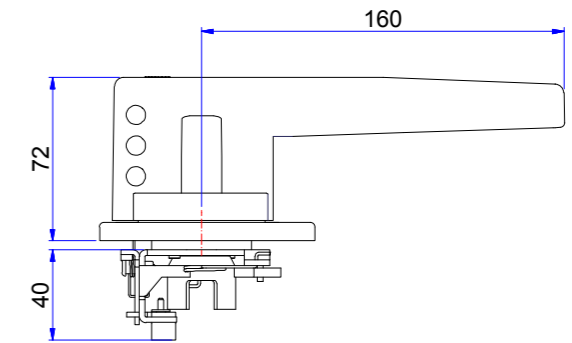

Foratura portella \_Door drilling

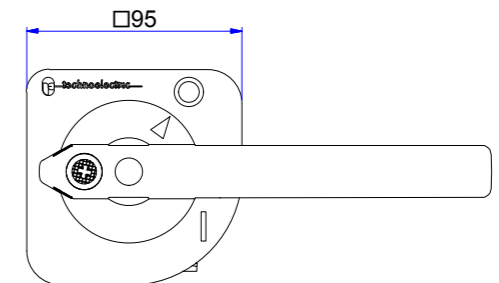
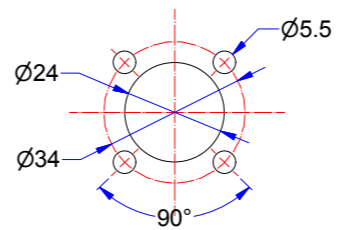

18832

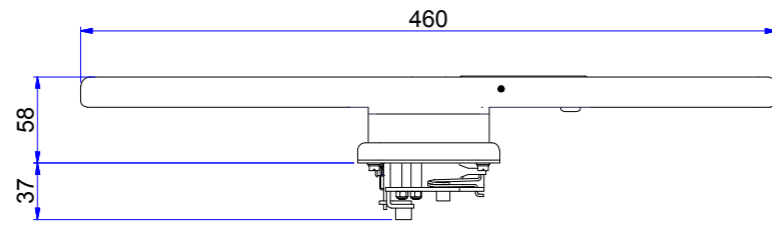

Foratura portella \_Door drilling

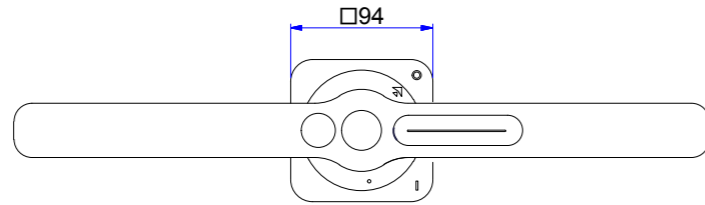
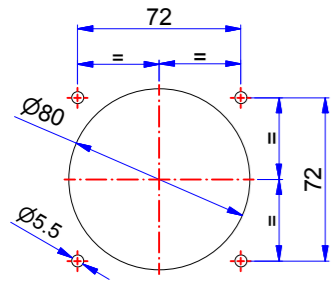

18850

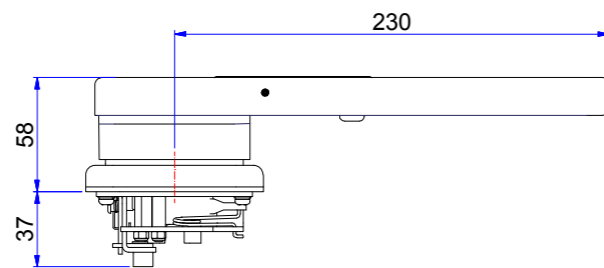

Foratura portella \_Door drilling

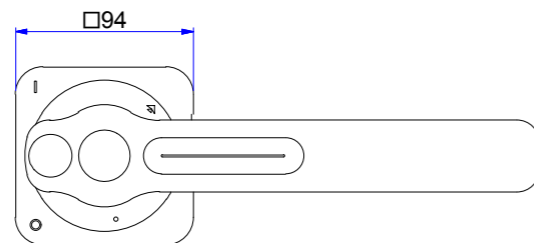
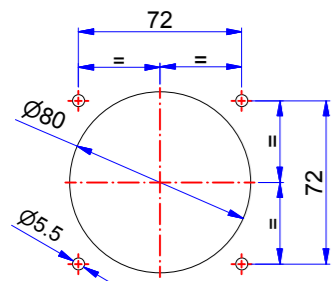

**MANIGLIA BLOCCO PORTA DI EMERGENZA  
CON DISPOSITIVO DI SBLOCCO CON ATTREZZO SPECIALE**  
**\_red/ yellow door interlock handle with defeater mechanism (special tool)**

Tipo_type	VC1F	VC2F	VC3F	VC4F	VC5F
Codice_code	18221	18221	18223	18223	18225

18221



Foratura portella \_Door drilling

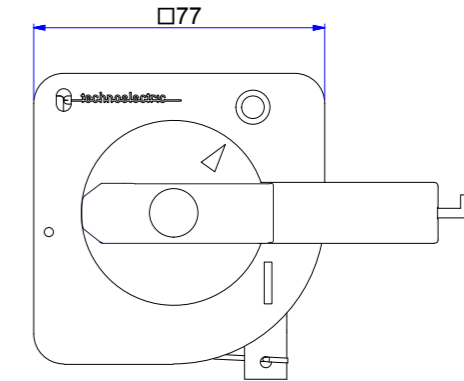
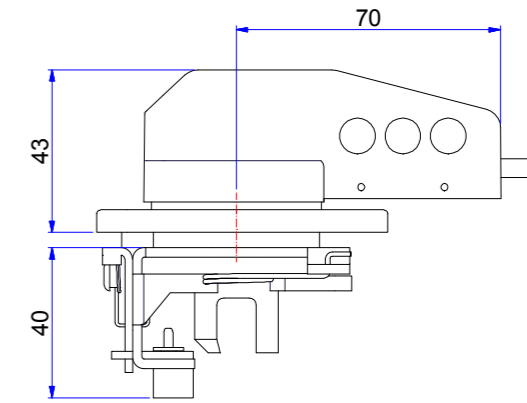
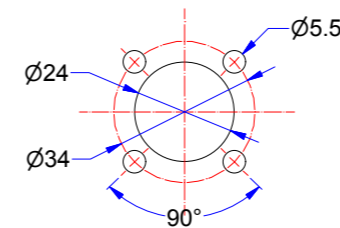

18223



Foratura portella \_Door drilling

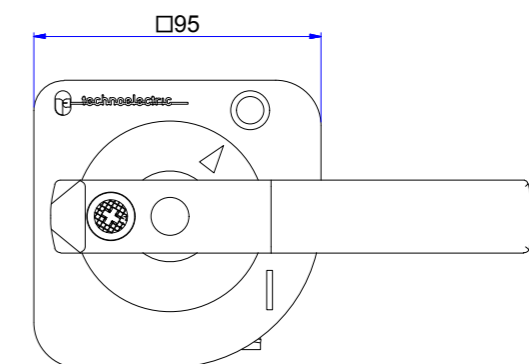
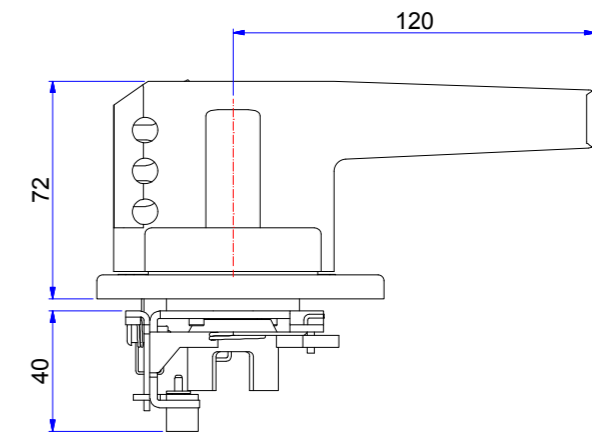
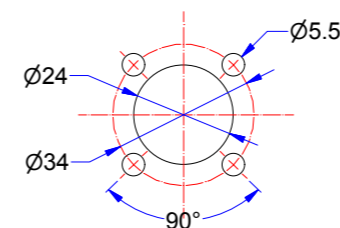



18225

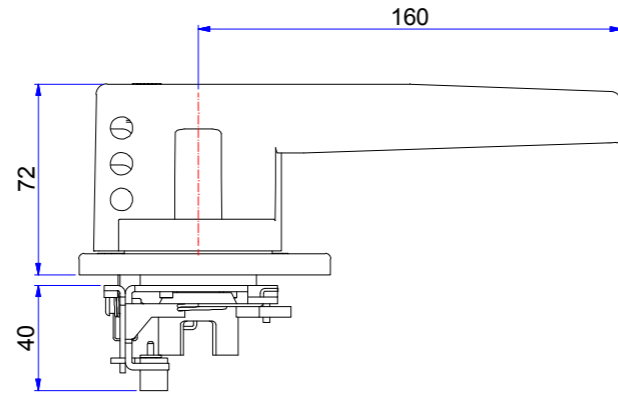

Foratura portella \_Door drilling

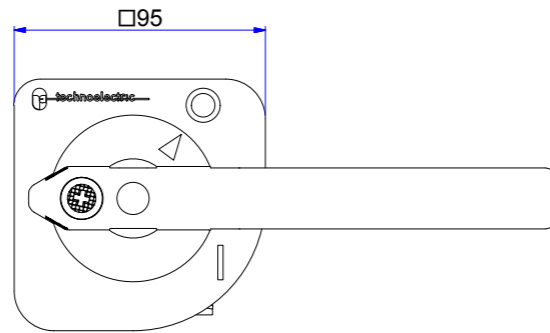
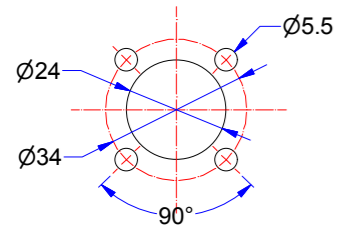

**MANIGLIA BLOCCO PORTA\EMERGENZA  
CON DOPPIA FUNZIONE DI SICUREZZA**  
\_black/emergency door interlock handle with defeater mechanism

Tipo_type	VC1F	VC2F	VC3F	VC4F	VC5F
Codice_code	18234 18235	18234 18235	18234 18235	18236 18237	18236 18237

18234

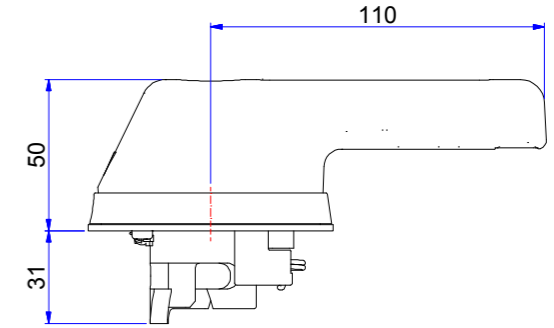

Foratura portella \_Door drilling

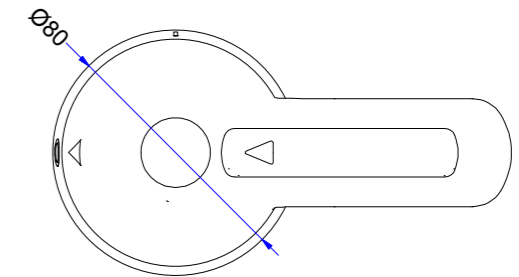
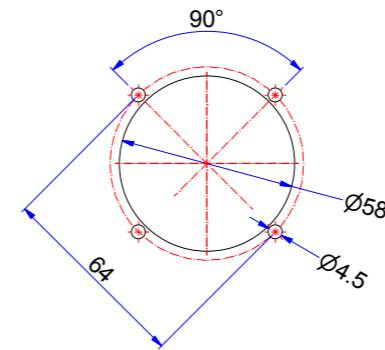

18236

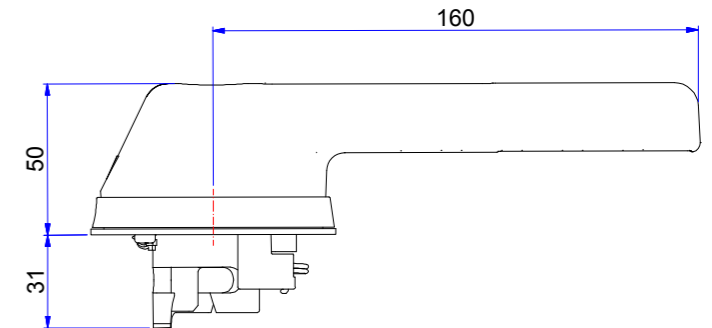

Foratura portella \_Door drilling

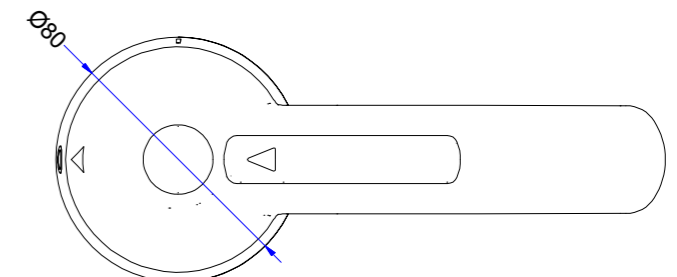
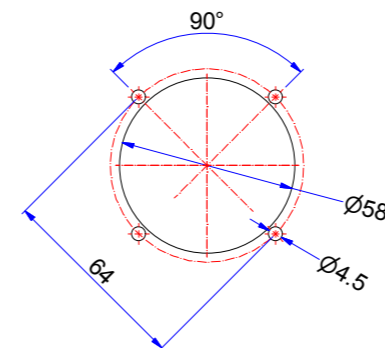

18235

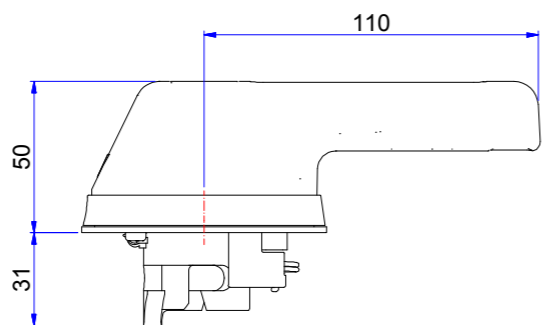

Foratura portella \_Door drilling

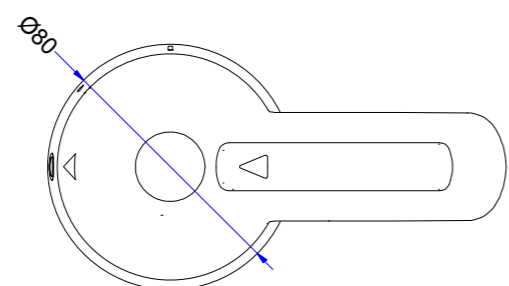
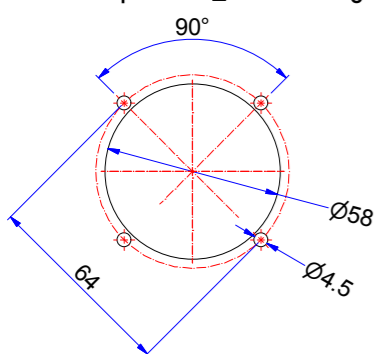

18837

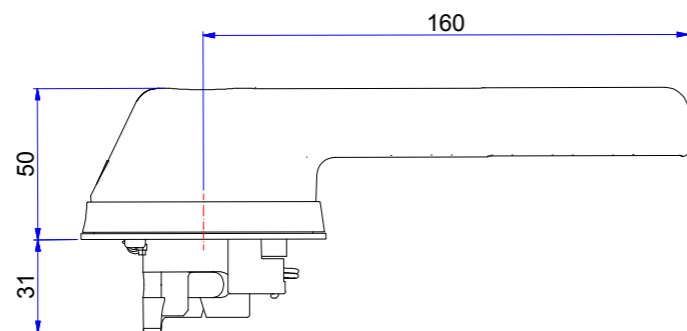

Foratura portella \_Door drilling

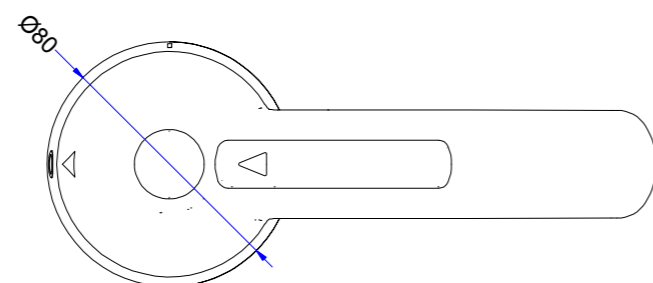
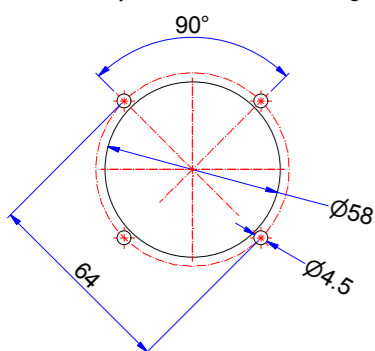

Adatta per montaggio su portella con dispositivo di blocco porta in posizione On Grado di protezione IP 65  
Disponibile anche nella versione per emergenza (rosso\gialla)

\_For door mounting with Door interlocking in "On" position IP 65 degree of protection  
Available also for emergency operation (red\yellow)

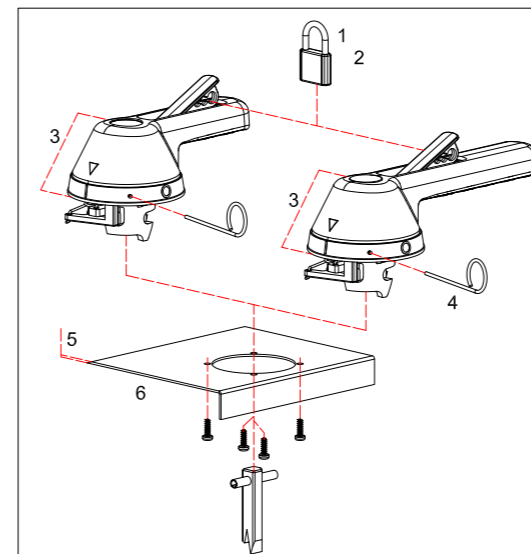

Foratura portella \_Door drilling

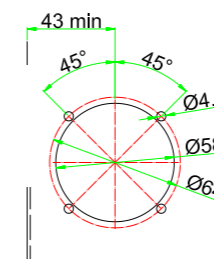

<b>1</b>	Lucchettabile (max 3 lucchetti 1xø8+2xø6) in posizione Off.	Padlockable in "Off" position (with max 3 padlocks of 1xø8+2xø6).
<b>2</b>	Apertura della portella impedita quando la maniglia è lucchettata in posizione di Off.	Door opening is prevented when the handle is padlocked in "Off" position.
<b>3</b>	Ingombro inferiore a 50 mm in profondità per permettere l'utilizzo anche in quadri a doppia portella.	Handle height less than 50 mm for suitability with two-doors type panels.
<b>4</b>	Permette, a mezzo di un apposito attrezzo, fornito con la maniglia, l'esclusione del dispositivo di blocco porta e quindi l'apertura della portella anche a interruttore in posizione di ON. Il dispositivo bloccoporta si ripristina automaticamente al chiudersi della porta.	With the use of the special tool (supplied), the door interlock mechanism can be bypassed maintaining the switch in the "On" position and the door can be opened. The door interlocking mechanism is automatically re-established when door is closed.
<b>5</b>	Può essere montata su portelle di qualsiasi spessore.	Can be mounted on doors of any thickness.
<b>6</b>	Posizione della maniglia fissa quando la portella é aperta.	When the door is open, the position of the handle is fixed

**CONTATTI AUSILIARI IN SCAMBIO 1NA + 1NC  
PER APERTURA ANTICIPATA**

\_auxiliary contacts 1NO + 1NC  
activated before main contacts



18165



18163

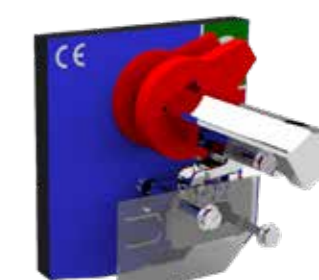

18160

Tipo _type	VC1F	VC2F	VC3F	VC4F	VC5F
Codice _code	18165	18165	18163	18160	18163

**CONTATTI AUSILIARI IN SCAMBIO 2NA + 2NC  
PER APERTURA ANTICIPATA**

**\_auxiliary contacts 2NO + 2NC  
activated before main contacts**

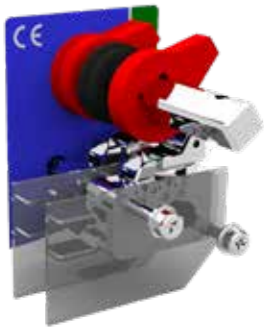

18166

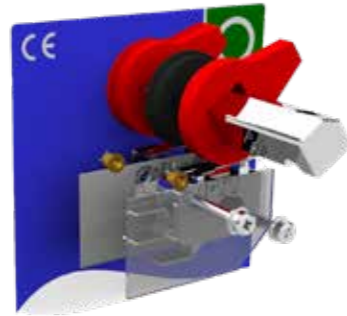

18164

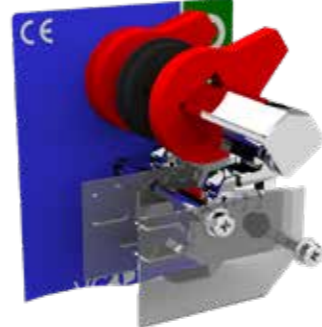

18161

Tipo_type	VC1F	VC2F	VC3F	VC4F	VC5F
Codice_code	18166	18166	18164	18161	18164

**CONTATTI AUSILIARI IN SCAMBIO 1NA + 1NC  
PER APERTURA POSTICIPATA**

**\_auxiliary contacts 1NO + 1NC  
activated after main contacts**

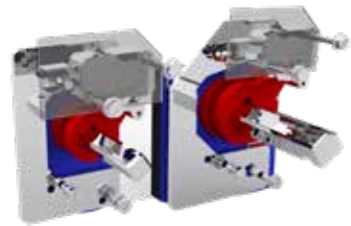

Tipo_type	VC1F	VC2F	VC3F	VC4F	VC5F
Codice_code	18120	18120	18127	18127	18127

**CONTATTI AUSILIARI IN SCAMBIO 2NA + 2NC  
PER APERTURA POSTICIPATA**

**\_auxiliary contacts 2NO + 2NC  
activated after main contacts**

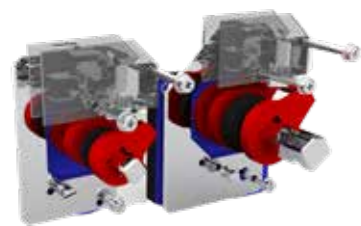

Tipo_type	VC1F	VC2F	VC3F	VC4F	VC5F
Codice_code	18123	18123	18128	18128	18128

Contatti ausiliari in scambio  
Apertura anticipata rispetto  
all'apertura dei contatti  
principali dell'interruttore Portata  
nominale 16A  
Portata termica 20A

\_Change over auxiliary contacts  
break before make contacts switches  
Rated current 16A  
Thermal current 20A

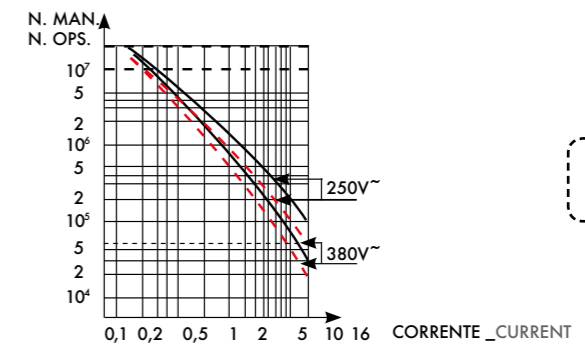

**CONTATTI AUSILIARI IN SCAMBIO 1NA+1NC  
\_auxiliary contacts 1NO+1NC**

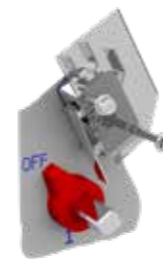

Tipo_type	EO1F	EO2F
Codice_code	18566 (plettta_lever)	

**CONTATTI AUSILIARI IN SCAMBIO 1NA+1NC  
\_auxiliary contacts 1NO+1NC**



Tipo_type	EO3F - EO4F - EO5F
Codice_code	18560 (rotella_roller)

**CONTATTI AUSILIARI IN SCAMBIO 2NA+2NC  
\_auxiliary contacts 2NO+2NC**



Tipo_type	EO1F	EO2F
Codice_code	18568	

**CONTATTI AUSILIARI IN SCAMBIO 2NA+2NC**  
**\_auxiliary contacts 2NO+2NC**

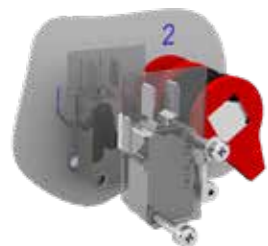

Tipo_type	EO3F - EO4F - EO5F
Codice_code	18567

**CALOTTA PROTEZIONE TERMINALI SUPERIORI**  
**\_upper terminal cover**

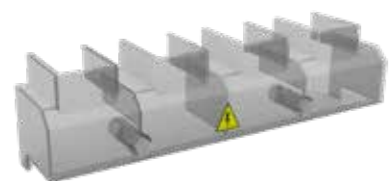

Tipo_type	VC1F	VC2F	VC3F	VC4F	VC5F
Codice_code	18050	18052	18350	18054	18056

**CALOTTA PROTEZIONE TERMINALI INFERIORI**  
**\_lower terminal cover**



Tipo_type	VC1F	VC2F	VC3F	VC4F	VC5F
Codice_code	18051	18053	18351	18055	18057

**SCHERMO PROTEZIONE FUSIBILI**  
**\_fuse cover**



Tipo_type	VC1F	VC2F	VC3F	VC4F	VC5F
Codice_code	18180	18181	18380	18183	18184

**SPESSORE RIALZO**  
**\_risers**



Tipo_type	VC1F	VC2F	VC3F	VC4F	VC5F
Codice_code	18290	18291	18292	18293	18293

Tipo_type	h/mm	Ø
VC1	5	15
VC2	5	18
VC3	10	17
VC4-5	15	24

**BLOCCO MANOVRA ELETTRICO**  
**\_electric interlock**

Tipo_type	Tensione_voltage	VC2F	VC3F	VC4F	VC5F
Codice_code	24 V dc	18119B	18117B	18116B	18115B
	230 V ac	18119B4	18117B4	18116B4	18115B4

altre tensioni a richiesta \_further versions upon request

Dispositivo di sicurezza adatto per il montaggio su interruttori di manovra sezionatori VC2-3-4-5F. Impedisce la manovra quando l'interruttore è in posizione Off. La manovra da Off a On è consentita solo alimentando la bobina. La bobina deve essere alimentata solo per il tempo necessario alla manovra. Disponibili nelle versioni con bobina 24 V dc oppure 220 V ac. A richiesta può essere fornito un dispositivo per blocco sia in posizione On che in posizione Off.

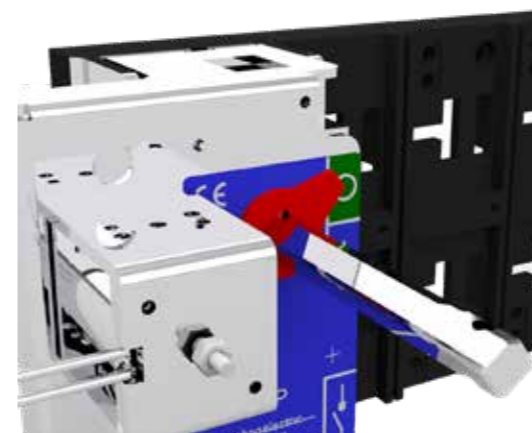

\_Safety device suitable for mounting on switch disconnectors VC2-3-4-5F. It prevents the switch to operate when it is in Off position. The operation from Off to On is possible when the coil is energised only. The coil can remain energised just for the time needed for the operation. Available with 24 V dc or 220 V ac coil. Device for locking in both positions available under request.





# INTERRUTTORI DI MANOVRA SEZIONATORI

SWITCHES DISCONNECTORS

TSM 25 ÷ 80A - TSP 80 ÷ 1250A





## SERIE\_TECHNOSOLAR

### GENERALITÀ

Gli interruttori-sezionatori della serie Technosolar nascono per applicazioni sulle energie rinnovabili

### IMPIEGO

Gli apparecchi sono abitualmente impiegati nelle seguenti funzioni:

Scaricatori  
Inverter  
Quadri di stringa  
Colonnine di Ricarica  
O in qualsiasi applicazione con corrente continua.

### CARATTERISTICHE GENERALI

Ottimo potere d'interruzione (DC21B)  
Tensione nominale di isolamento 1.500 VDC  
Tensione di Esercizio fino a 1.000 VDC  
Doppia interruzione per ogni polo  
Elevata durata meccanica ed elettrica  
Adatto per l'utilizzo in climi tropicali  
Grado di protezione ip20 (accessori inclusi)

### GAMMA

TSM, interruttori-sezionatori da guida DIN  
TSP, interruttori- sezionatori da fondo quadro  
TSP-MS, interruttori sezionatori motorizzati  
TSP-BA, interruttori - sezionatori con bobina di sgancio

### COMANDO

Comando di tipo rotativo frontale a mezzo di: maniglia esterna a doppio isolamento con blocco porta in posizione I, grado di protezione IP65, possibilità di 3 blocchi con lucchetto in posizione 0  
Maniglia diretta (a richiesta lucchettabile in posizione di 0

### CONDIZIONI NORMALI DI SERVIZIO, MONTAGGIO E TRASPORTO

Temperatura ambiente di immagazzinamento e trasporto - 25°C + 55°C  
Temperatura ambiente di funzionamento - 20°C + 40°C  
in caso di temperatura ambiente (ta) superiore, applicare la seguente formula di declassamento:

$$I_{The} = k I_{Th} \text{ dove } k = 1 - \frac{t - 40}{100}$$

Umidità relativa max 95%  
Frequenza nominale 50 - 60 Hz  
Altitudine max 2000 m s.l.m.  
Grado di inquinamento 3 secondo IEC 60947-1  
Possono essere montati in qualsiasi posizione.  
Montaggio in custodia: in caso di utilizzo a piena corrente e in mancanza di adeguata ventilazione assicurare un volume pari a circa 5 volte quello dell'apparecchio  
Tipo di servizio (secondo IEC 60947-1): 8 ore; ininterrotto; intermittente 60% classe 30; temporaneo; periodico.

Per condizioni di impiego diverse consultare il costruttore.

### CONFORMITÀ ALLE NORME

IEC 60947-1 | IEC 60947-3 | UNI EN 60947-1 | UNI EN 60947-3

### CERTIFICATI E OMOLOGAZIONI

INTEK | RINA

### \_GENERALITIES

The switch disconnectors of the Technosolar series are designed for applications on renewable energy or where there is the need of a use in DC.

### \_USE

The devices are usually used in the following applications:  
Unloaders  
Inverter  
String combiner box  
Charging Columns  
Or in any other DC application.

### \_GENERAL CHARACTERISTICS

Excellent breaking capacity (DC21B)  
Rated insulation voltage 1,500 VDC  
Operating voltage up to 1.000 VDC  
Double interruption for each pole  
High mechanical and electrical durability  
Suitable for use in tropical climates  
Degree of protection ip20 (accessories included)

### \_RANGE

TSM, DIN rail switch-disconnectors  
TSP, plate mounted switch-disconnectors  
TSP-MS, Motorized switch disconnectors  
TSP-BA, switches - disconnectors with release coil

### \_OPERATING MECHANISM

Black (standard execution) or emergency direct handle padlockable in 0 position. Handle with door interlock handle, black or emergency handle padlockable with up to three padlocks in 0 position.  
IP 65 degree of protection.  
Direct handle (padlockable in 0 position on request)

### \_STANDARD SERVICE, MOUNTING AND TRANSPORT CONDITIONS

Storage and transport ambient temperature - 25°C + 55°C  
Working ambient temperature - 20°C + 40°C  
In case of higher ambient temperature (ta) consider the following derating formula:

$$I_{the} = k I_{th} \text{ dove } k = 1 - \frac{t - 40}{100}$$

Relative humidity max 95%  
Rated frequency 50 - 60 Hz  
Altitude max 2000 m a.s.l.  
Pollution degree 3 according IEC 60947-1  
Can be mounted in any position, for what concerns the positioning, please refer to the installation instructions  
Mounting in enclosure: in case of utilisation at full load and without adequate ventilation, ensure a volume of about 5 times the volume of the switch  
Duty (IEC 60947-1): 8 hours; uninterrupted; intermittent 60% class 30; temporary; periodic.

For different operating conditions, please contact the manufacturer.

### \_CONFORMITY TO STANDARDS

IEC 60947-1 | IEC 60947-3 | UNI EN 60947-1 | UNI EN 60947-3

### \_CERTIFICATES AND APPROVALS

INTEK | RINA





**SERIE\_TECHNOSOLAR**

Codice ordinazione _Reference code	<b>TS013M</b>	<b>TS014M</b>	<b>TS015M</b>	<b>TS016M</b>	<b>TS028M</b>	<b>TS038M</b>	
Tensione nominale d'isolamento _Rated insulation voltage	1500	1500	1500	1500	1500	1500	
Corrente nominale termica Ith (A a 40° C) _Rated thermal current Ith (A a 40° C)	25A	30A	35A	40A	60A	80A	
Tensione nominale impulso Uimp (kV) _Impulse withstand voltage Uimp (kV)	8	8	8	8	8	8	
Tensione nominale d'impiego in DC-20 _Rated operational voltage ui in DC-20	1500	1500	1500	1500	1500	1500	
Corrente nominale In (A) in DC21-B _Rated operational current In (A) in DC21-B	400Vdc	25	30	35	40	60	80
	500Vdc	25	30	35	40	45	65
	600Vdc	15	20	25	40	40	60
	750Vdc	10	15	20	25	30	40
	800Vdc	10	15	20	25	30	40
	1000Vdc	-	-	-	-	-	-
N° di poli in serie _N° of poles in series	3	4	5	6	8	8	
Corrente breve durata per 1 sec a 400V (kA) _Short-circuit withstand current 1 sec. a 400V (kA)	1,1	1,1	1,1	1,1	1,5	3	
Massima dimensione cavo Cu (mm²) _Max cable section Cu (mm²)	16	16	16	16	35	70	
Massima torsione terminali (NM) _Max terminal torque (NM)	2	2	2	2	2	6	
Sforzo di manovra (nm) _Operating torque (nm)	1,6	1,6	1,6	1,6	1,6	2,6	
Durata meccanica (N° manovre) _Mechanical endurance (N° of operations)	50.000	50.000	50.000	50.000	30.000	30.000	
Comando diretto (per uso in centralino) _Direct operation (for use on modular panels)	Si _Yes	Si _Yes	Si _Yes	Si _Yes	Si _Yes	No	
Peso netto _Net weight	0,13	0,16	0,19	0,30	0,65	1,05	

Codice ordinazione _Reference code	<b>TS043P</b>	<b>TS046P</b>	<b>TS056P</b>	<b>TS063P</b>	<b>TS073P</b>	<b>TS083P</b>	<b>TS093P</b>	<b>TS103P</b>	
Tensione nominale d'isola- mento _Rated insulation voltage	1500	1500	1500	1500	1500	1500	1500	1500	
Corrente nominale termica Ith (A a 40° C) _Rated thermal current Ith (A a 40° C)	80A	100A	250A	400A	800A	800A	1000A	1250A	
Tensione nominale impulso Uimp (kV) _Impulse withstand voltage Uimp (kV)	8	8	12	12	12	12	12	12	
Tensione nominale d'impie- go in DC-20 _Rated operational voltage ui in DC-20	1500	1500	1500	1500	1500	1500	1500	1500	
Corrente nominale In (A) in DC21-B _Rated operational current In (A) in DC21-B	400Vdc	80	100	250	400	800	800	1000	1250
	500Vdc	60	100	160	400	630	800	1000	1250
	600Vdc	30	80	125	300	400	800	1000	1250
	750Vdc	30	80	125	300	350	800	1000	1250
	800Vdc	30	80	125	300	350	800	1000	1250
	1000Vdc	-	-	-	-	-	800	1000	1250
N° di poli in serie _N° of poles in series	3	6	6	3	3	3	3	3	
Corrente breve durata per 1 sec a 400V (kA) _Short-circuit withstand cur- rent 1 sec. a 400V (kA)	5	5	8	12	26,5	35	50	50	
Massima dimensione cavo Cu (mm²) _Max cable section Cu (mm²)	50+70	50+70	70+120	185+300	300+480	2x240 2x50x5	2x50x6	2x50x8	
Massima torsione terminali (NM) _Max terminal torque (NM)	-	-	-	-	-	-	-	-	
Sforzo di manovra (nm) _Operating torque (nm)	16	16	24	18	34	45	70	70	
Durata meccanica (N° manovre) _Mechanical endurance (N° of operations)	10.000	10.000	10.000	8.000	8.000	5.000	5.000	5.000	
Comando diretto (per uso in centralino) _Direct operation (for use on modular panels)	No	No	No	No	No	No	No	No	
Peso netto _Net weight	0,9	2,2	3,4	3,5	5,5	11	11	11	

**TS013M**

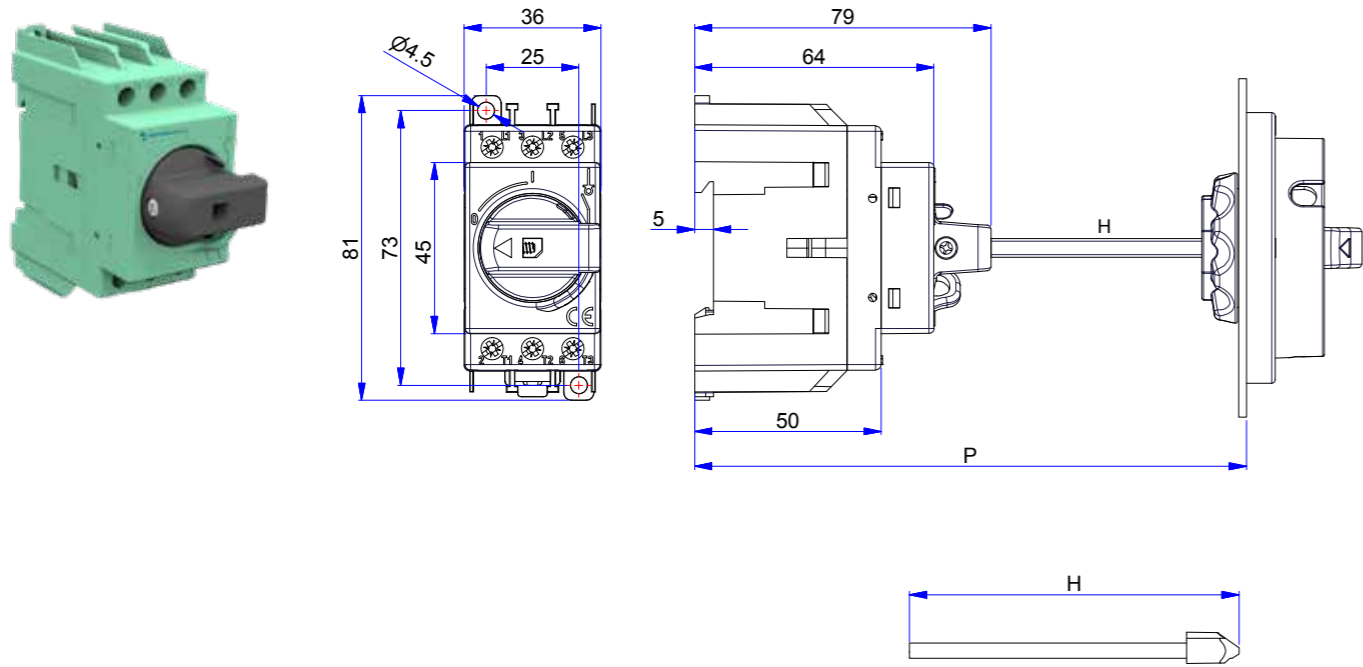

**TS015M**

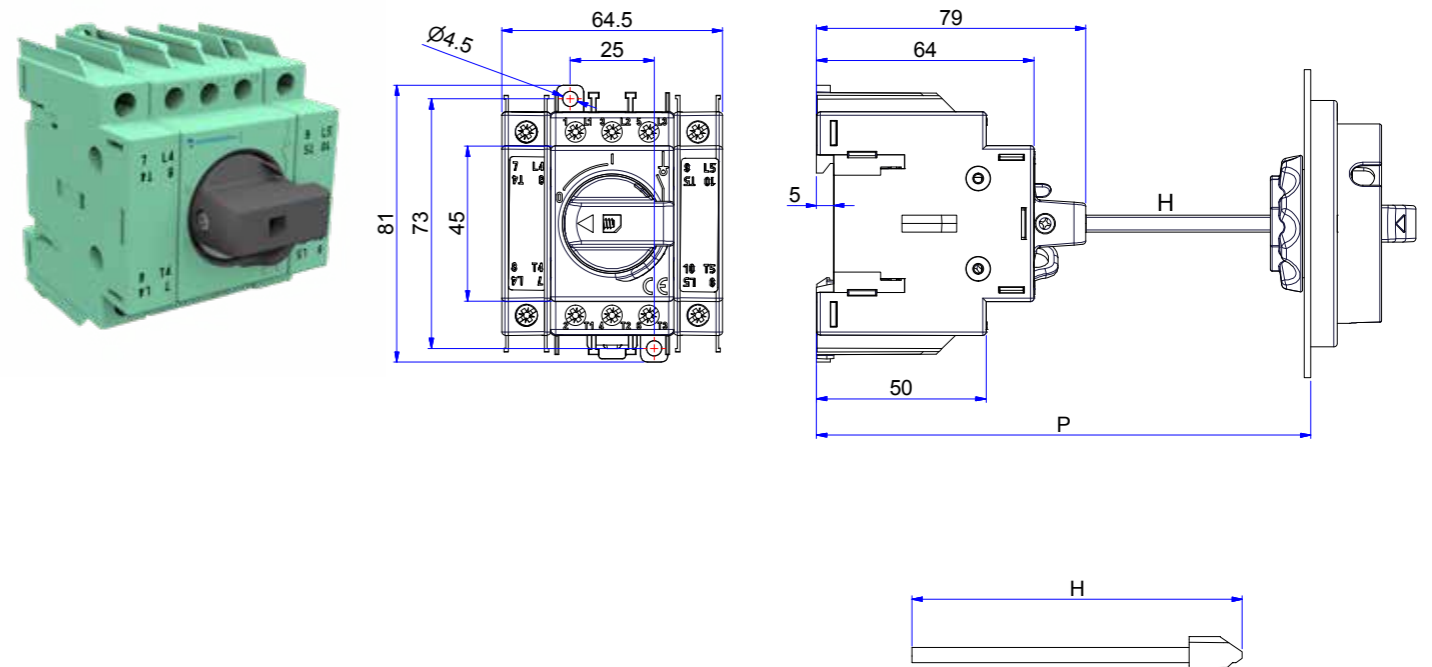

**TS014M**

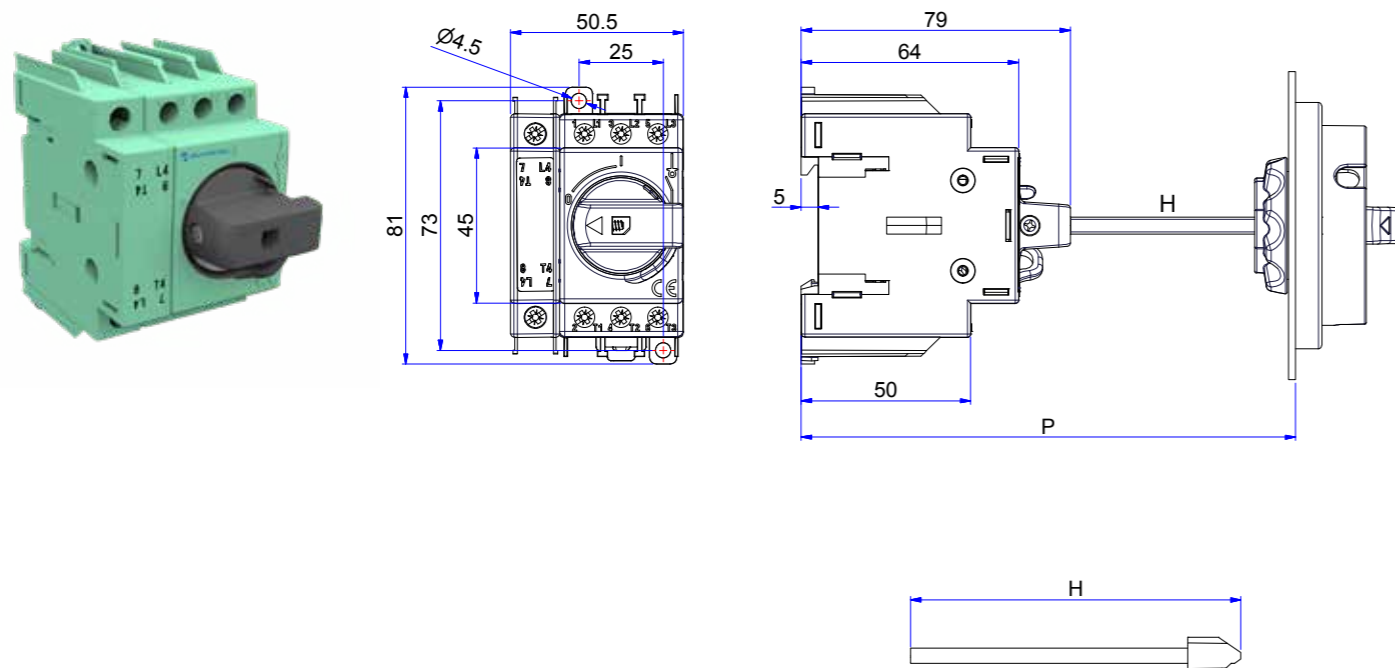

**TS016M**

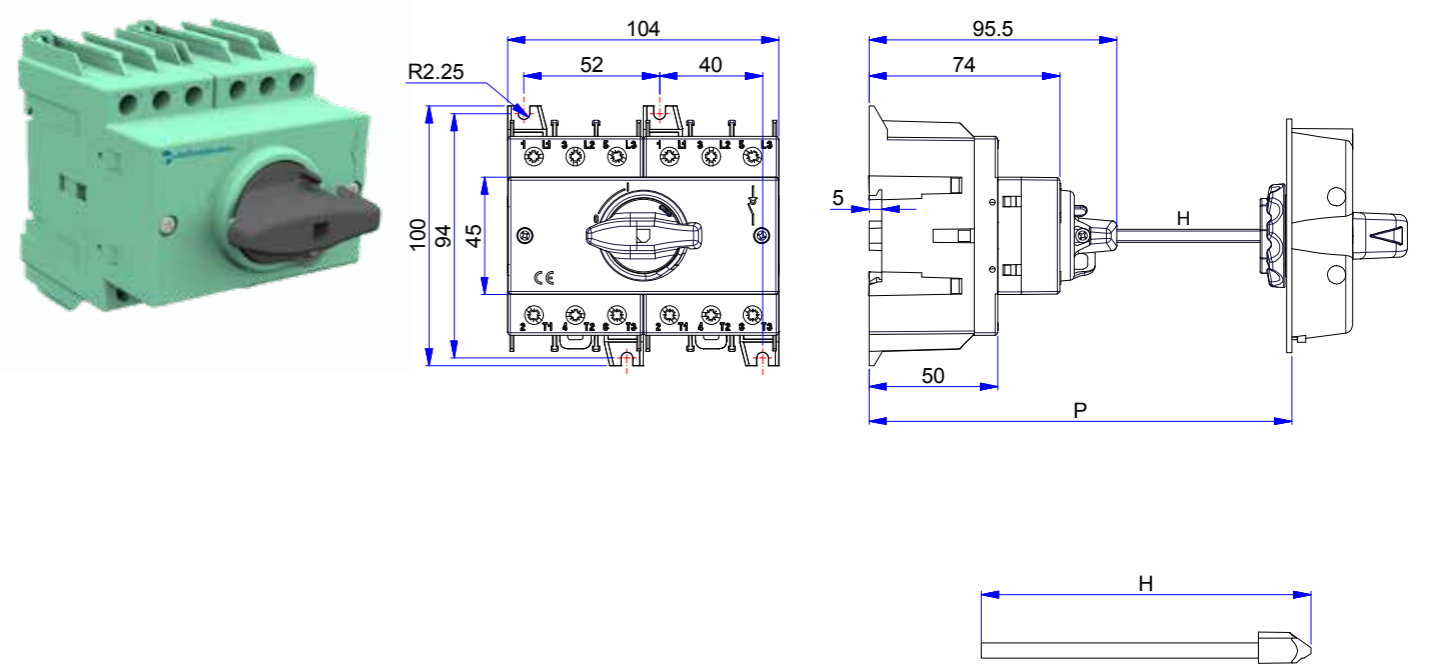



**TS028M**

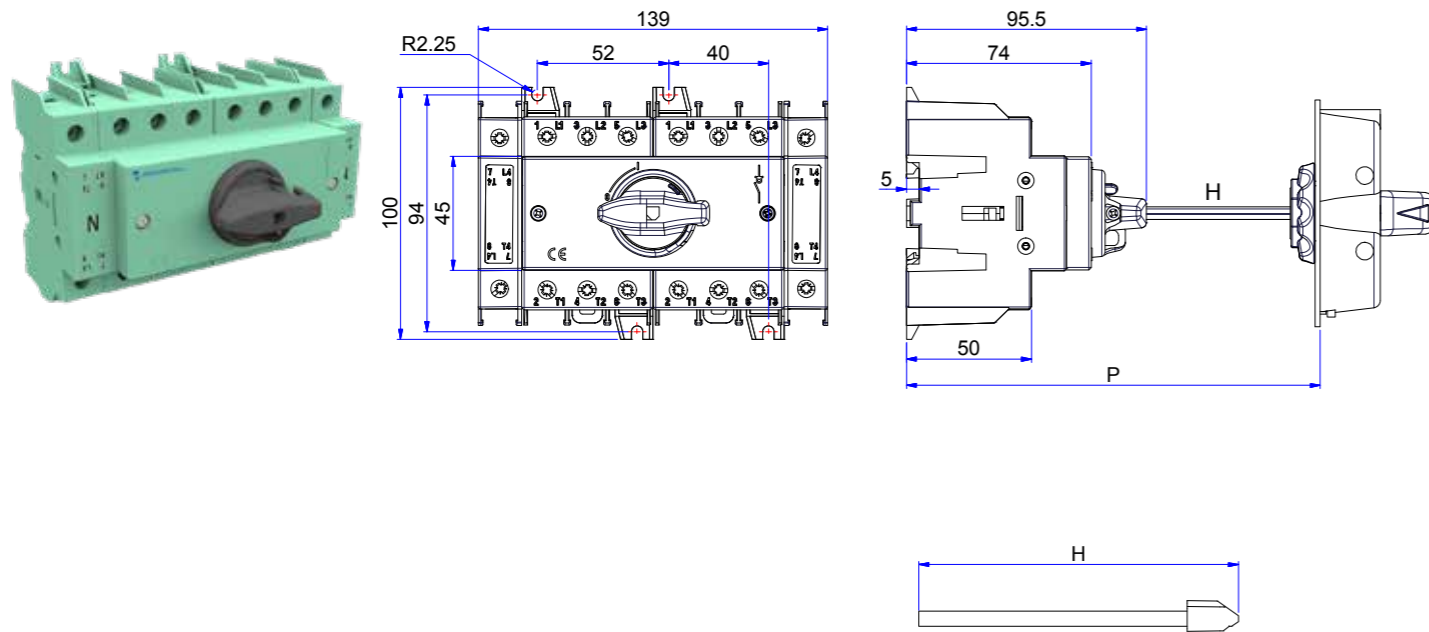

**TS043P**

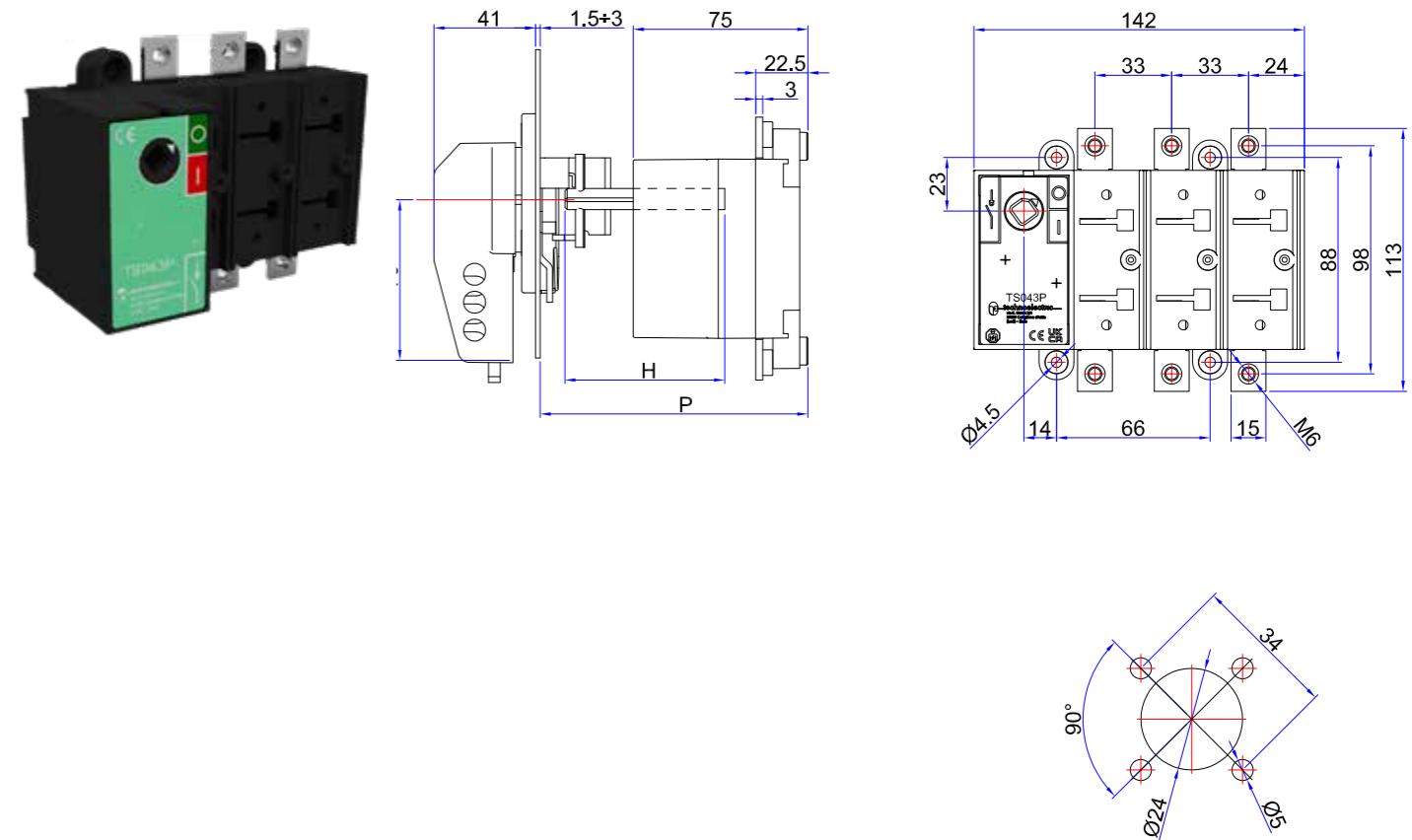

**TS038M**

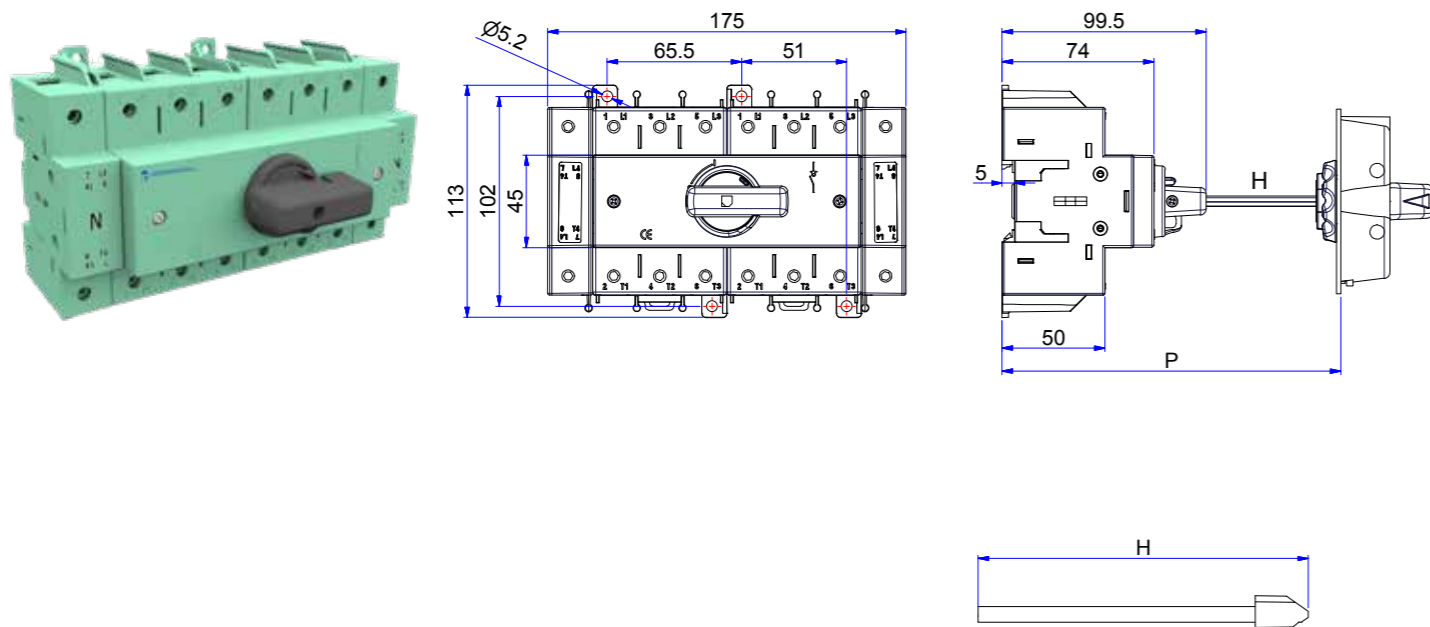

**TS046P**

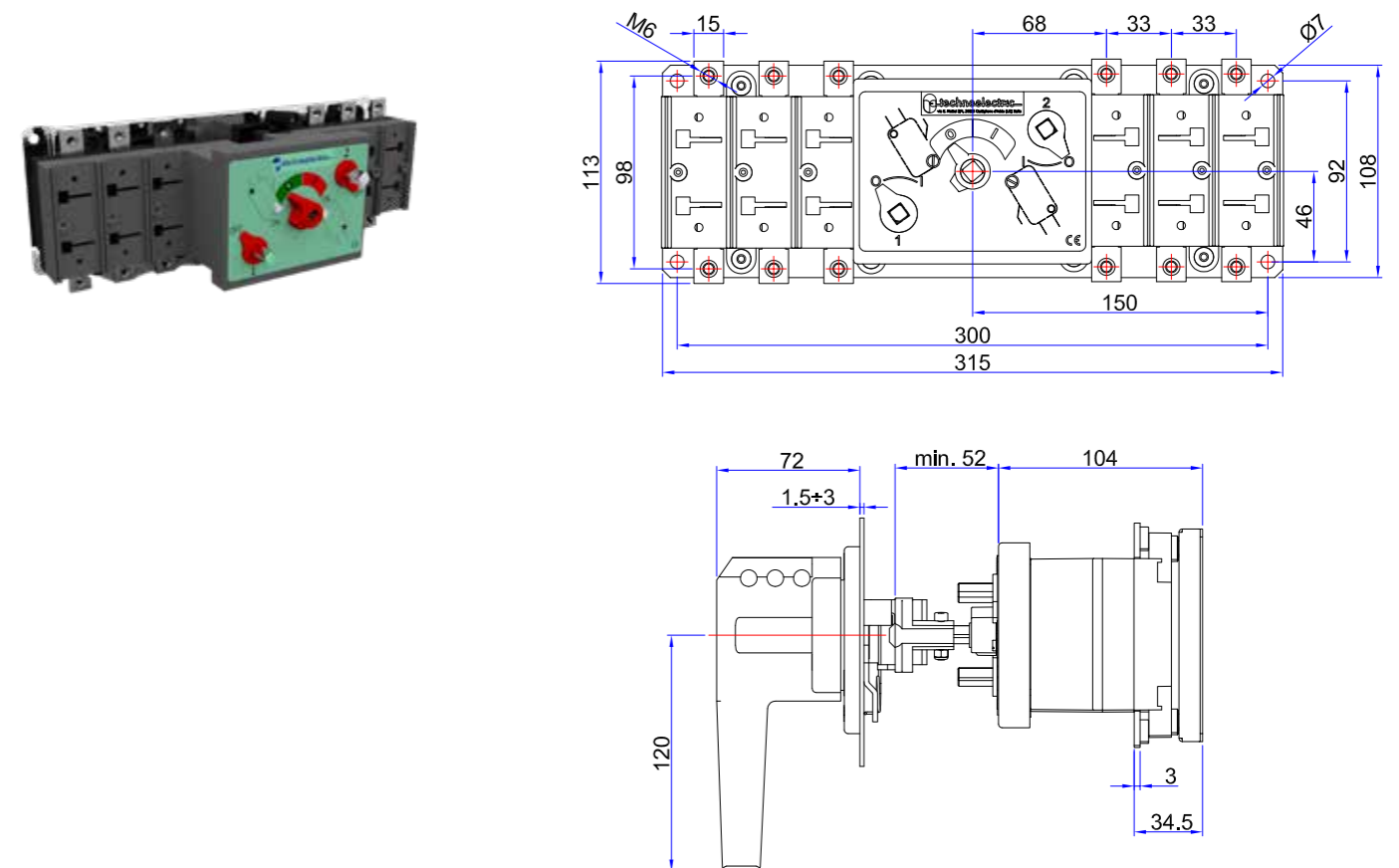

**TS056P**

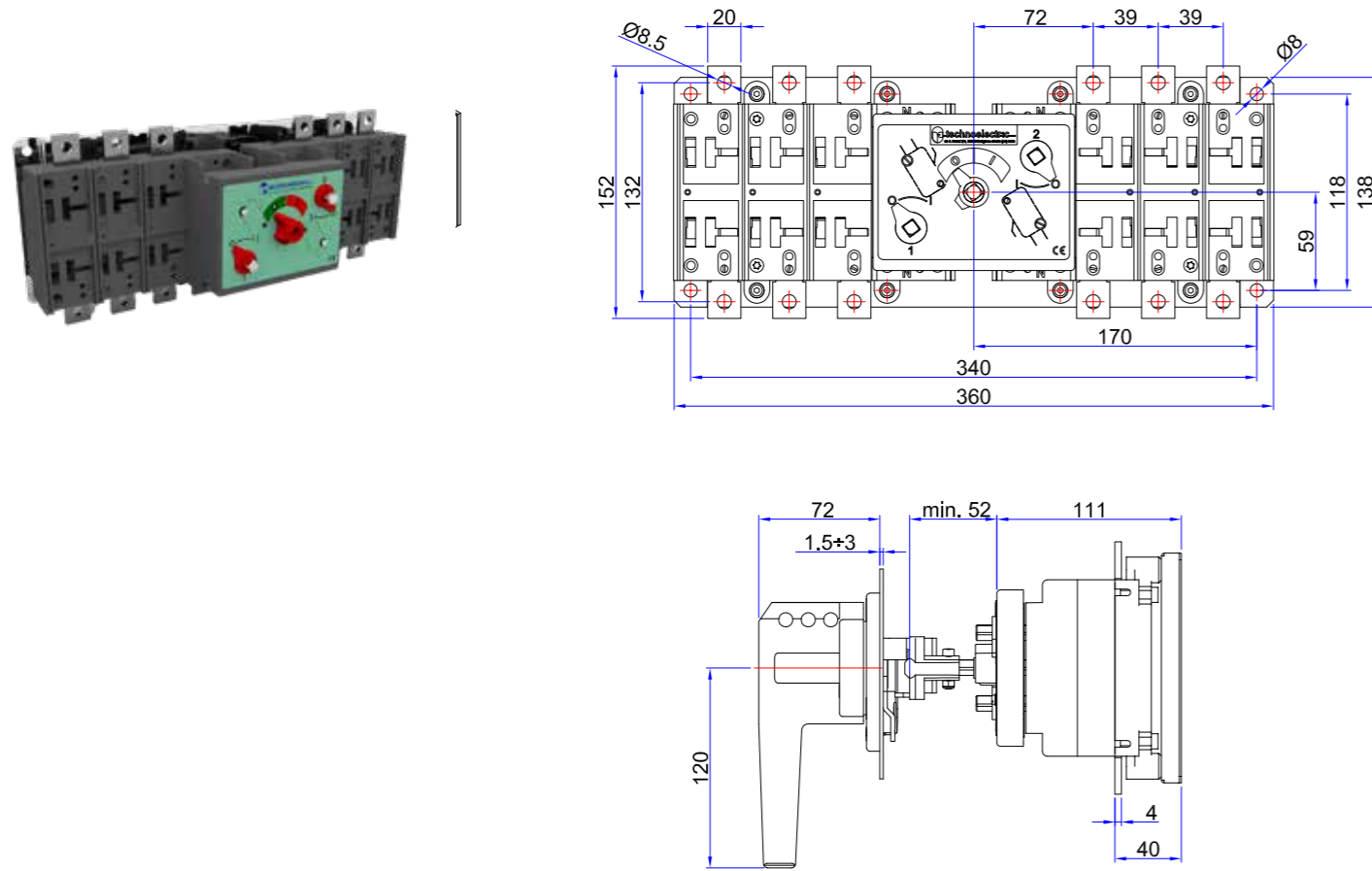

**TS073P**

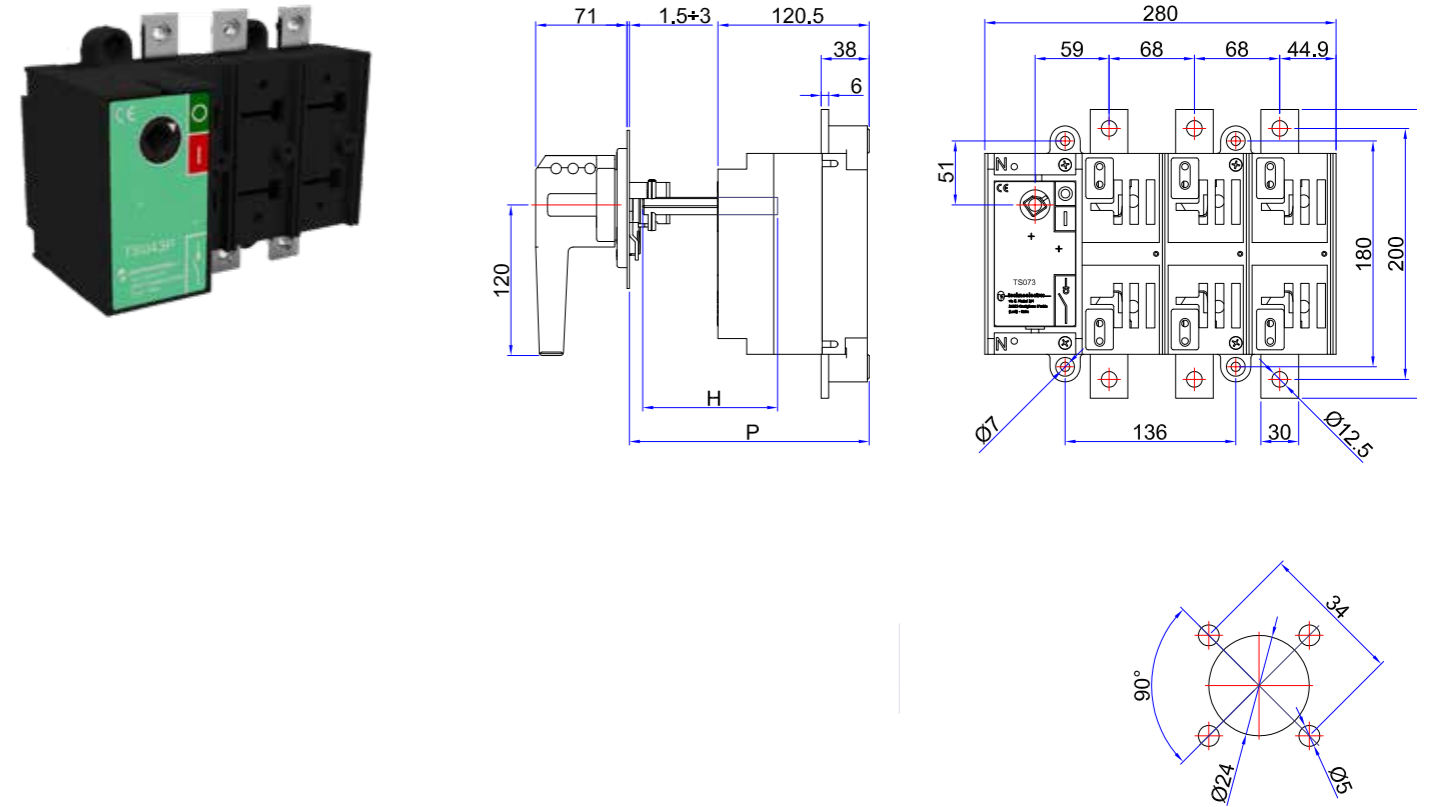

**TS063P**

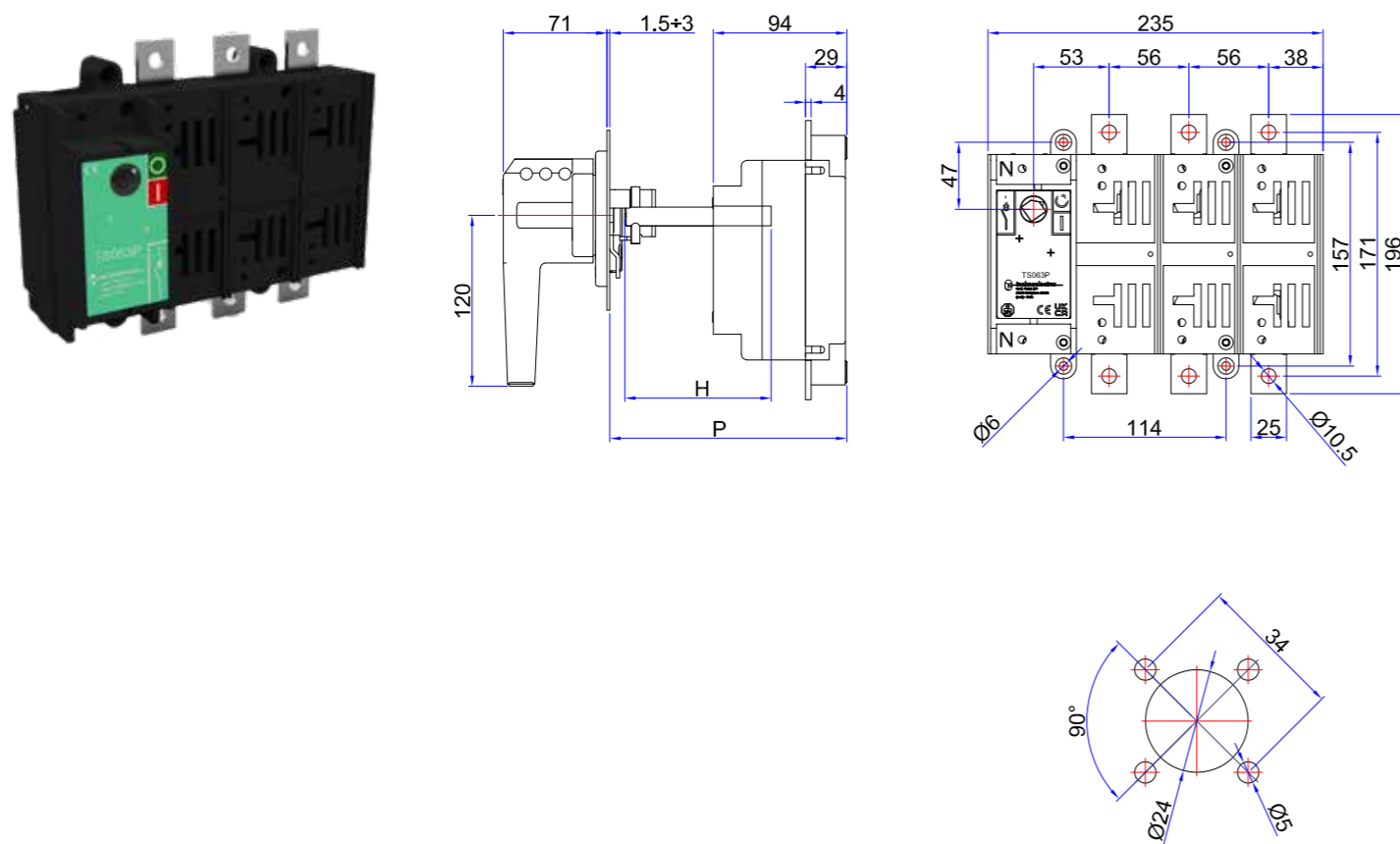

**TS083P - TS093P - TS103P**

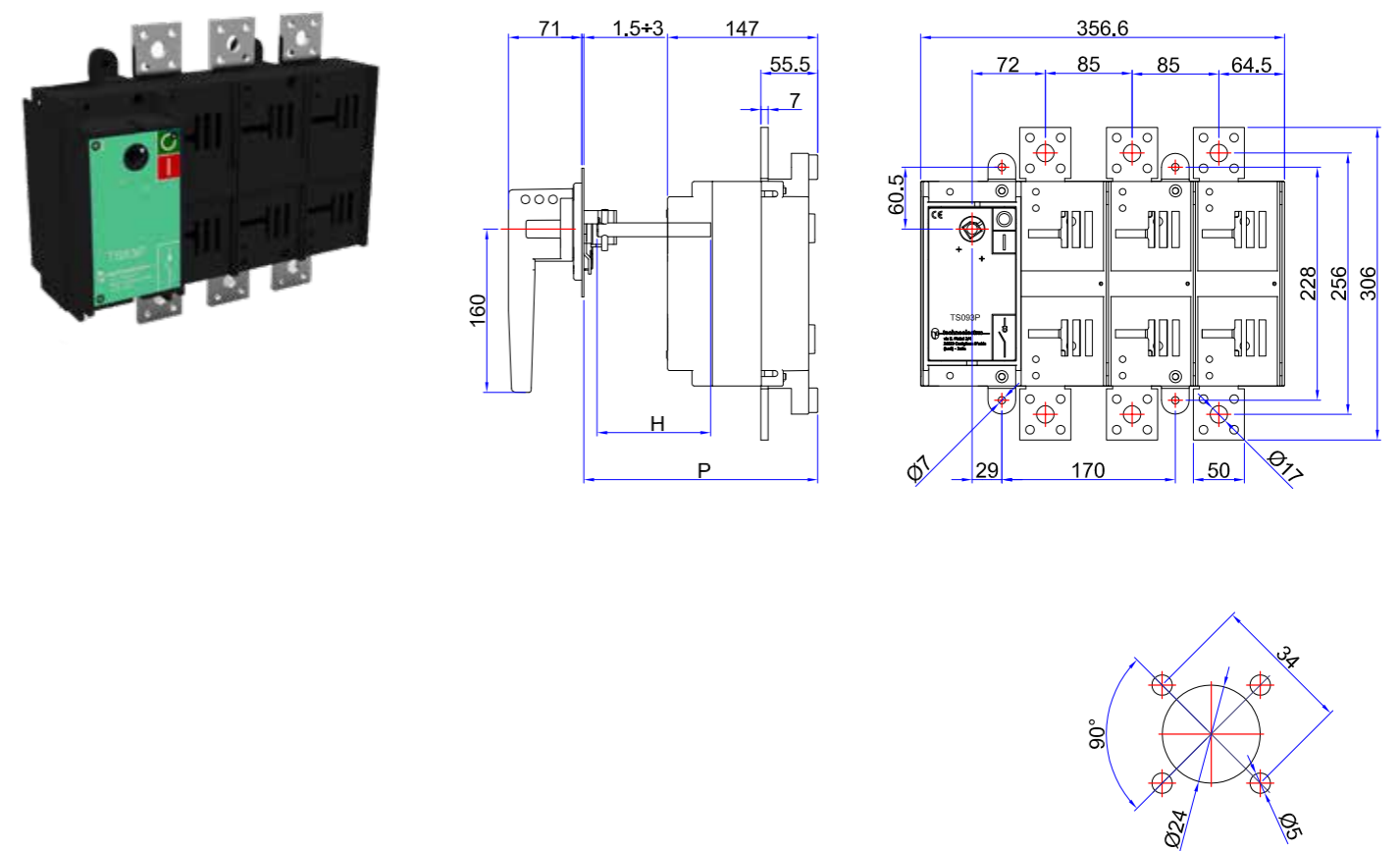

**SERIE\_TECHNOSOLAR**

Codice ordinazione _Reference code	TSP-MS					
	TS063PMS	TS073PMS	TS083PMS	TS093PMS	TS103PMS	
Tensione nominale d'isolamento _Rated insulation voltage	1500	1500	1500	1500	1500	
Corrente nominale termica Ith (A a 40° C) _Rated thermal current Ith (A a 40° C)	400A	800A	800A	1000A	1250A	
Tensione nominale impulso Uimp (kV) _Impulse withstand voltage Uimp (kV)	12	12	12	12	12	
Tensione nominale d'impiego in DC-20 _Rated operational voltage ui in DC-20	1500	1500	1500	1500	1500	
Corrente nominale In (A) in DC21 _Rated operational current In (A) in DC21						
	400Vdc	400	800	800	1000	1250
	500Vdc	400	630	800	1000	1250
	600Vdc	300	400	800	1000	1250
	750Vdc	300	350	800	1000	1250
	800Vdc	300	350	800	1000	1250
	1000Vdc	-	-	800	1000	1250
N° di poli in serie _N° of poles in series	3	3	3	3	3	
Corrente breve durata per 1 sec a 400V (kA) _Short-circuit withstand current 1 sec. a 400V (kA)	12	26,5	35	50	50	
Massima dimensione cavo Cu (mm²) _Max cable section Cu (mm²)	185+300	300+480	2x240 2x50x5	2x50x6	2x50x8	
Sforzo di manovra (nm) _Operating torque (nm)	18	34	45	70	70	
Durata meccanica (N° manovre) _Mechanical endurance (N° of operations)	8.000	8.000	7.000	4.000	4.000	
Comando diretto (per uso in centralino) _Direct operation (for use on modular panels)	No	No	No	No	No	
Peso netto _Net weight	12,5	15	18,5	19	19	

Codice ordinazione _Reference code	24 V cc/DC	TSP-BA			
		TS073PB	TS083PB	TS093PB	TS103PB
V aux bobina _V aux coil	48 V cc/DC	<b>TS073PB1</b>	<b>TS083PB1</b>	<b>TS093PB1</b>	<b>TS103PB1</b>
	110 V cc/DC	<b>TS073PB2</b>	<b>TS083PB2</b>	<b>TS093PB2</b>	<b>TS103PB2</b>
	110 V ac/AC	<b>TS073PB3</b>	<b>TS083PB3</b>	<b>TS093PB3</b>	<b>TS103PB3</b>
	220 V ac/AC	<b>TS073PB4</b>	<b>TS083PB4</b>	<b>TS093PB4</b>	<b>TS103PB4</b>
Tensione nominale d'isolamento _Rated insulation voltage	1500	1500	1500	1500	
Corrente nominale termica Ith (A a 40° C) _Rated thermal current Ith (A a 40° C)	800A	800A	1000A	1250A	
Tensione nominale impulso Uimp (kV) _Impulse withstand voltage Uimp (kV)	12	12	12	12	
Tensione nominale d'impiego in DC-20 _Rated operational voltage ui in DC-20	1500	1500	1500	1500	
Corrente nominale In (A) in DC21 _Rated operational current In (A) in DC21					
	400Vdc	800	800	1000	1250
	500Vdc	630	800	1000	1250
	600Vdc	400	800	1000	1250
	750Vdc	350	800	1000	1250
	800Vdc	350	800	1000	1250
	1000Vdc	-	800	1000	1250
N° di poli in serie _N° of poles in series	3	3	3	3	
Corrente breve durata per 1 sec a 400V (kA) _Short-circuit withstand current 1 sec. a 400V (kA)	26,5	35	50	50	
Massima dimensione cavo Cu (mm²) _Max cable section Cu (mm²)	300+480	2x240 2x50x5	2x50x6	2x50x8	
Sforzo di manovra (nm) _Operating torque (nm)	34	45	70	70	
Durata meccanica (N° manovre) _Mechanical endurance (N° of operations)	8.000	7.000	4.000	4.000	
Comando diretto (per uso in centralino) _Direct operation (for use on modular panels)	No	No	No	No	
Peso netto _Net weight	8,2	13	13,5	13,5	

**TS063PMS**

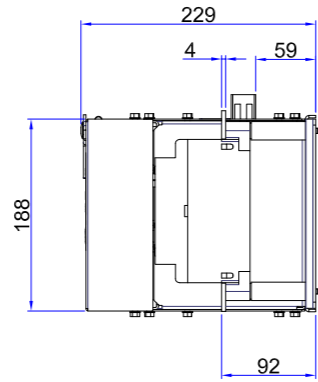
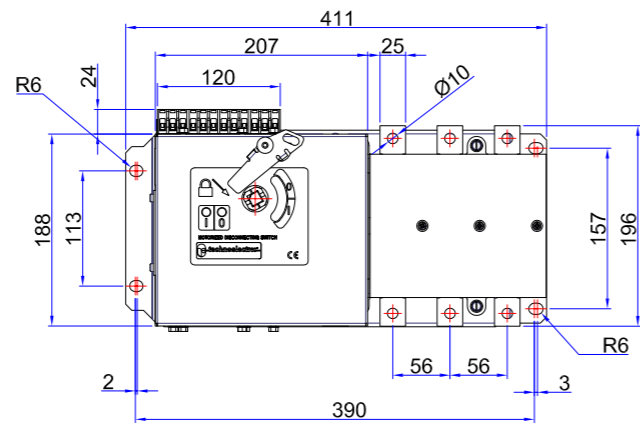

**TS083PMS - TS093PMS - TS103PMS**

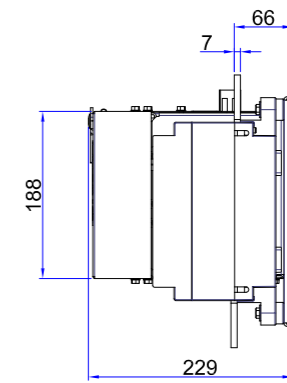
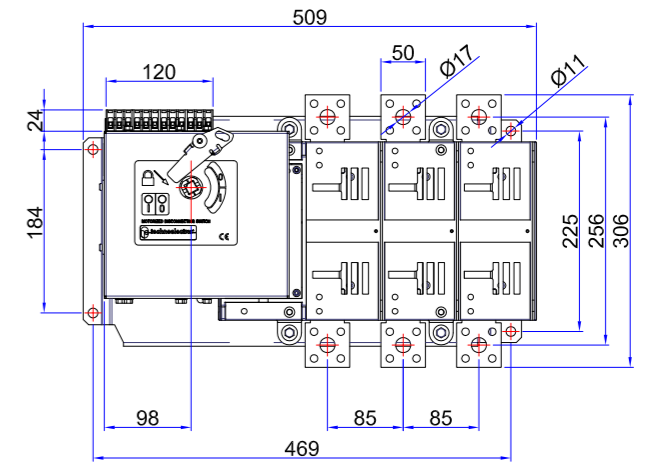

**TS073PMS**

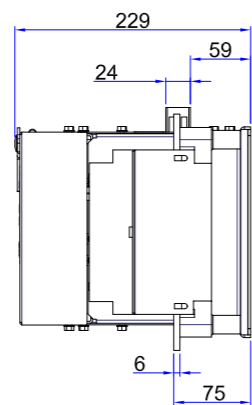
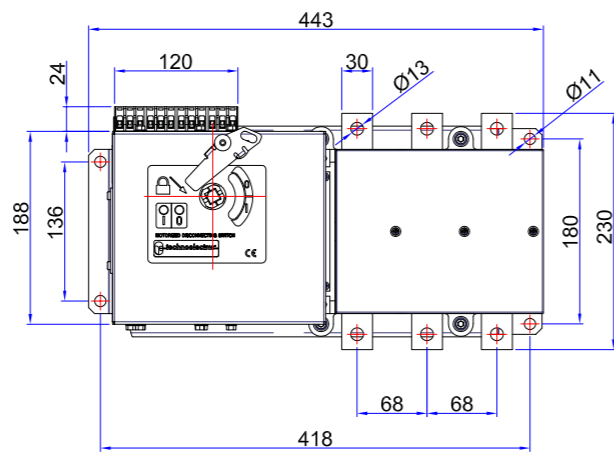

**TS073PB**

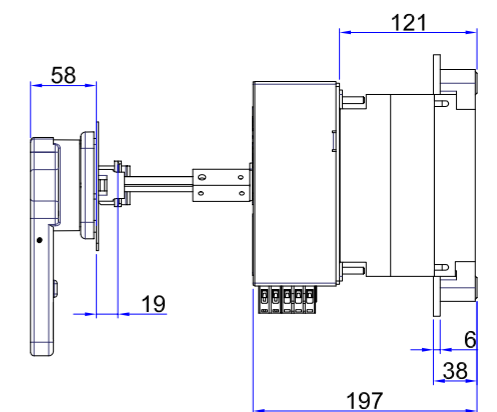
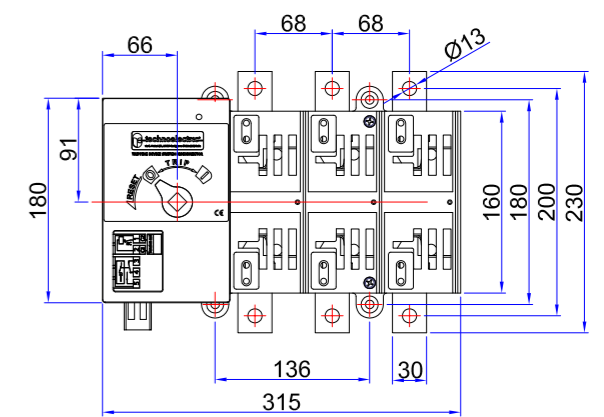



TS083PB

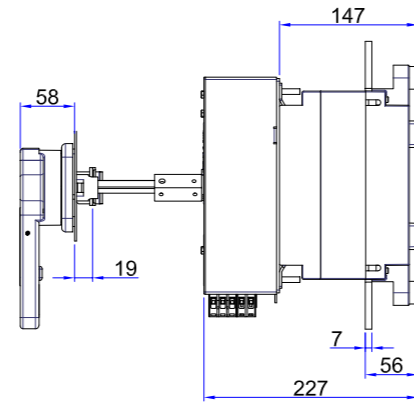
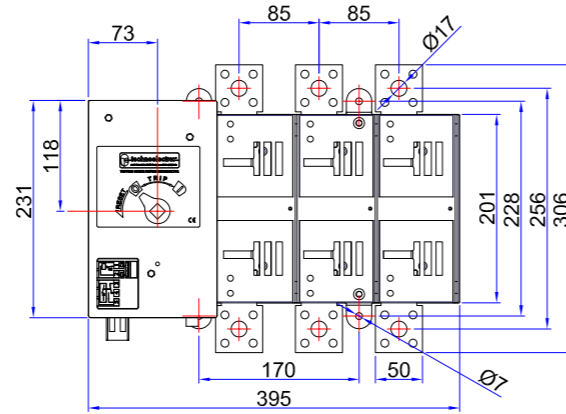

ACCESSORI TSM \_tsm accessories  
MANIGLIE BLOCCO PORTA \_Door interlock handles



19460

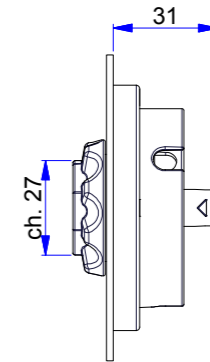
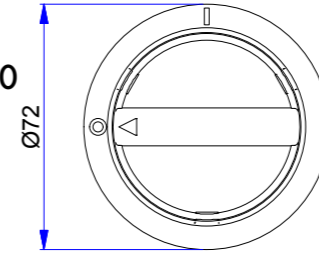

Foratura portella \_Door drilling

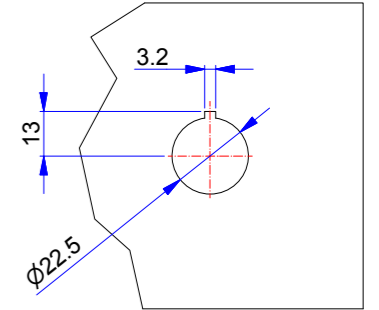

MANIGLIA CON SBLOCCO PORTA  
\_handle with defeater mechanism



19466

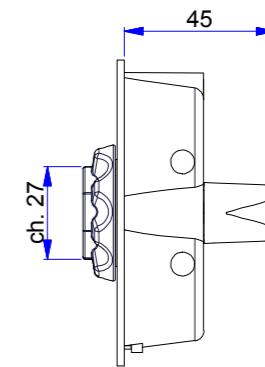
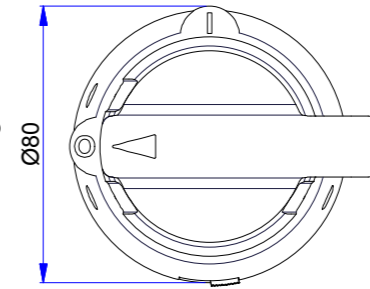

Foratura portella \_Door drilling

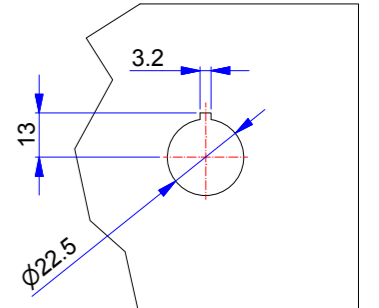

ALBERI DI COMANDO CON PUNTALE  
\_shaft for external operation with tip



Tipo _type	TSM alluminio _aluminium			TSM acciaio _steel		
Poli _poles	3 - 4 - 5			3 - 4 - 5   6 - 8		
mm	100	200	300	100	200	300
Codice_ code	19535-100P	19535-200P	19535-300P	19534-100P	19534-200P	19534-300P

## SERIE\_TECHNOSOLAR

montaggio poli aggiuntivi  
\_additional poles assembly

montaggio contatti ausiliari  
\_auxiliary contacts assembly

montaggio poli aggiuntivi + contatti ausiliari  
\_additional poles + auxiliary contacts assembly

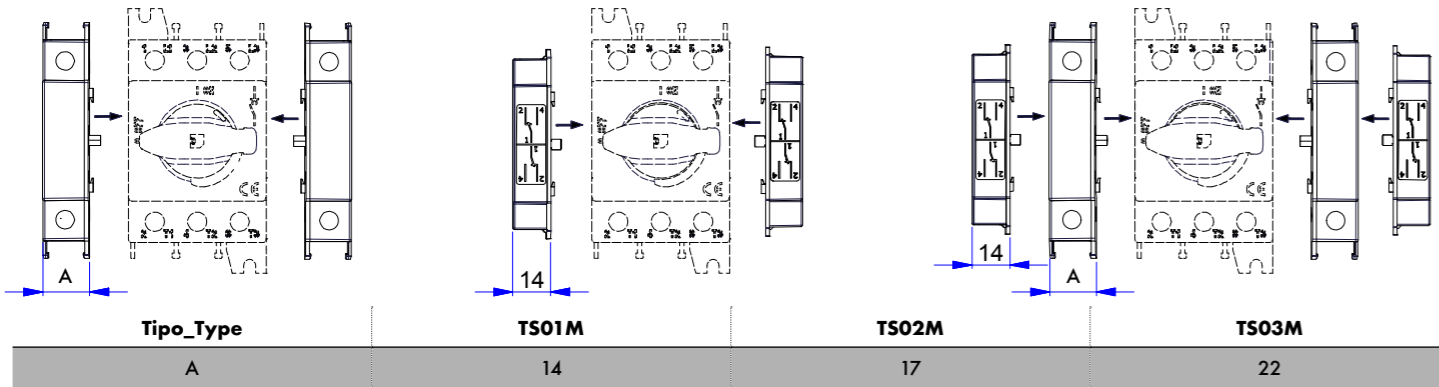

Per il montaggio dei contatti ausiliari addossati al 4° polo, ordinare la confezione viti cod 11190311  
\_For the installation of the auxiliary contacts on the 4th pole, please order the screws set with code 11190311

Contatti ausiliari in scambio  
Apertura anticipata rispetto  
all'apertura dei contatti  
principali dell'interruttore Portata  
nominale 16A  
Portata termica 20A

\_Change over auxiliary contacts  
break before make contacts switches  
Rated current 16A  
Thermal current 20A

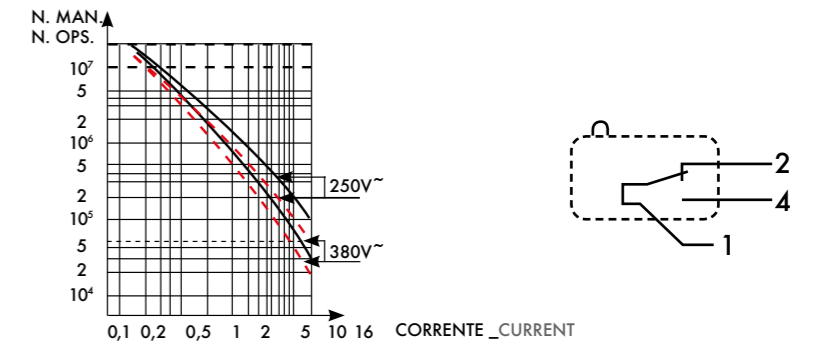

### CONTATTI AUSILIARI IN SCAMBIO 1NA + 1NC \_Change over auxiliary contacts 1NO + 1NC



Tipo_Type	TS01M	TS02M	TS03M
Codice_code	19442	19443	19444

### MORSETTO DI TERRA \_Earthing neutral



Tipo_Type	TS01M	TS02M	TS03M
Codice_code	19322	19422	19452

### KIT COPRI TERMINALI 4° POLO \_4th pole terminals cover kit



### KIT COPRI TERMINALI 3 POLI \_3 poles terminals cover kit

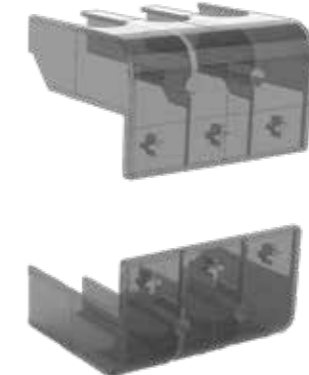

### MORSETTO ADATTATORE 200A PER CAVI DA 95MM<sup>2</sup> \_Terminal adapter for 95 mm<sup>2</sup> cables



Il codice include 3 pezzi \_3 pcs in each code

Codice\_code :19565

Number of pole	Max. Cross section	Nominal current	Nominal voltage
1	120	200-190	690

### NEUTRO PASSANTE \_Solid neutral



Tipo_Type	TS01M	TS02M	TS03M
Codice_code	19321	19420	19451

### 4° POLO CONTEMPORANEO \_Contemporary 4th pole



Tipo_Type	TS01M	TS02M	TS03M
Codice_code	19442	19443	19444

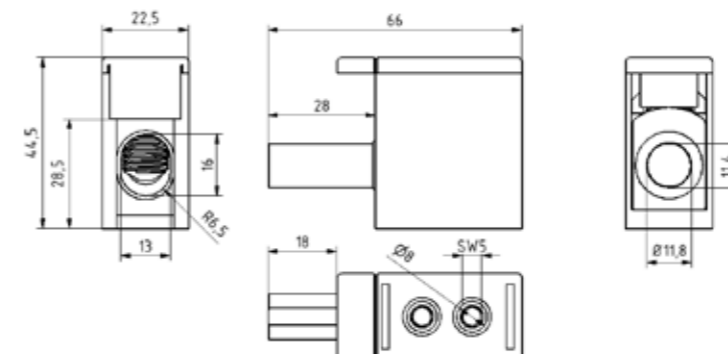

Adattatore per terminali per cavo da 95 mmq. per il collegamento di conduttori in alluminio e rame alle apparecchiature. Il corpo è in alluminio stagnato e l'alloggiamento è in poliammide.

\_Terminal Adapter for 95 sqmm cable. for connecting Al-and Cu-conductors to equipment. Body is made of tin-plated aluminium and housing is polyamid.

SERIE\_TECHNOSOLAR  
**MANIGLIA DIRETTA NERA PER TS P**  
**\_direct interlock handlr for TS P**

Tipo_type	TS043P	TS046P	TS056P	TS063P	TS073P	TS083P	TS093P	TS0103P
Codice_code	18020	18588	18589	18320	18022	18023 18007	18852 18840	18852 18840

**18001**

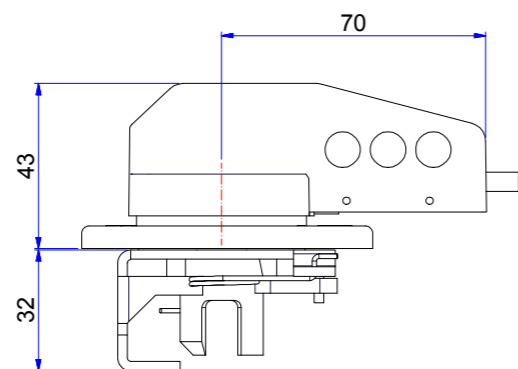

Foratura portella \_Door drilling

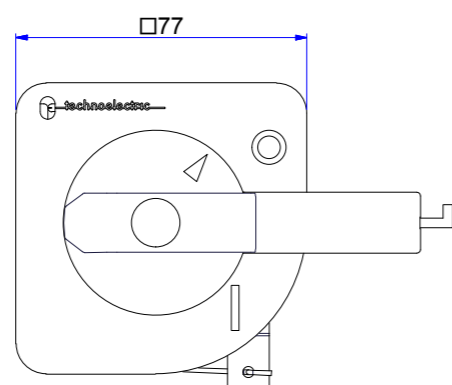
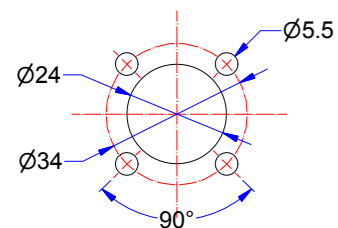

**18003**

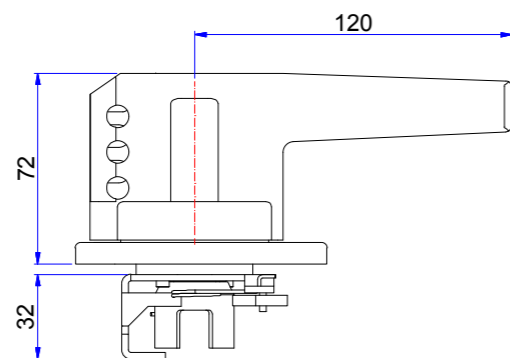

Foratura portella \_Door drilling

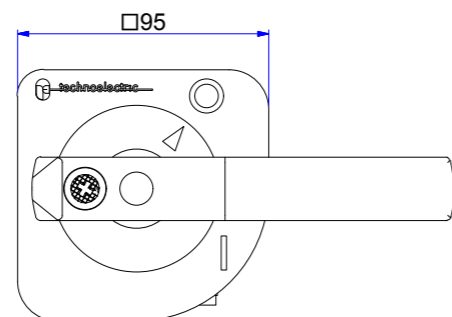
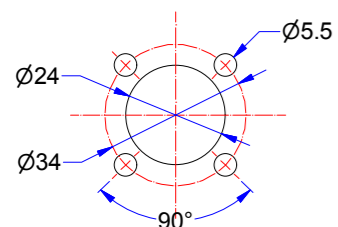

**18005**

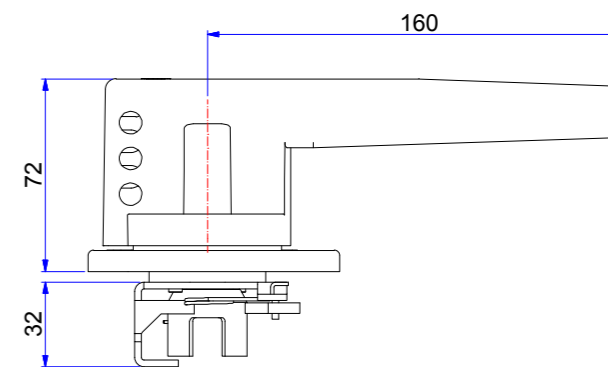

Foratura portella \_Door drilling

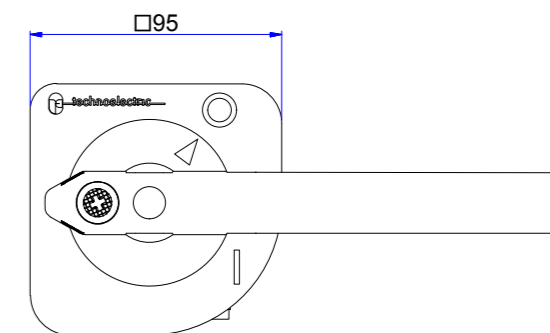
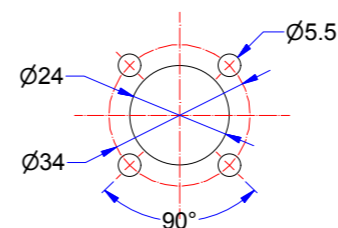

**18007**

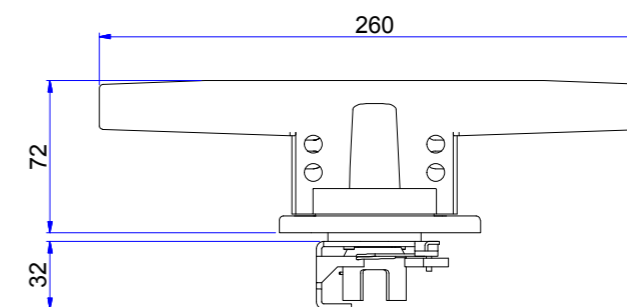

Foratura portella \_Door drilling

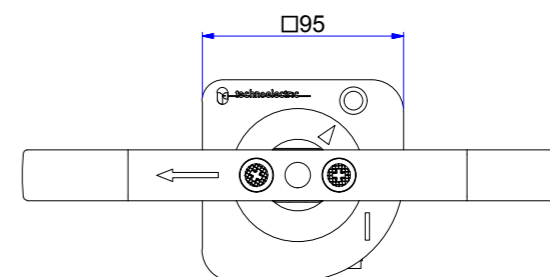
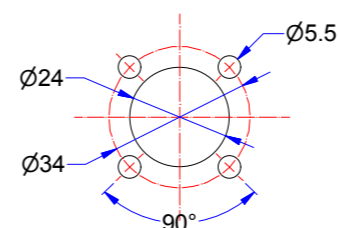

18830

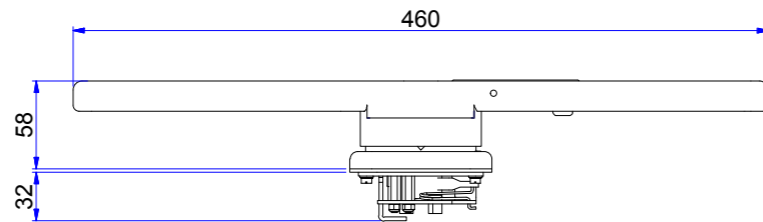

Foratura portella \_Door drilling

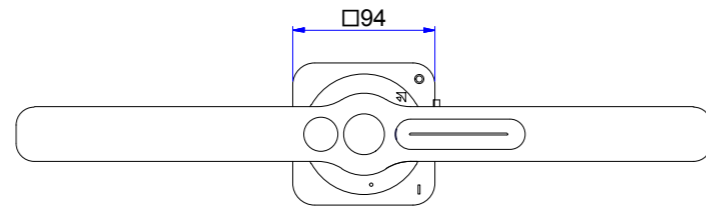
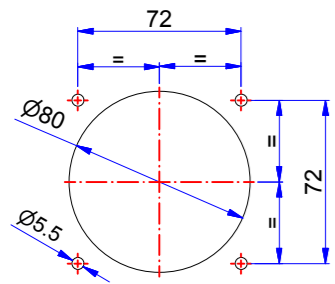

18844

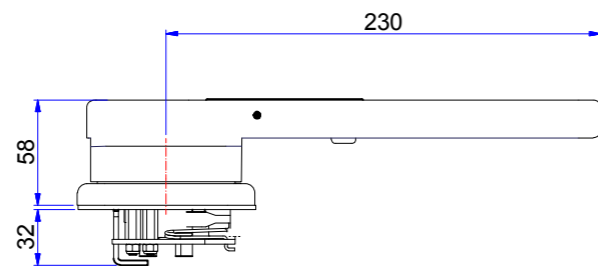

Foratura portella \_Door drilling

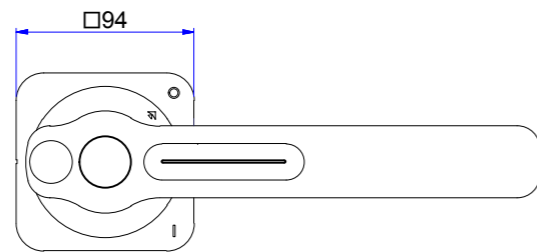
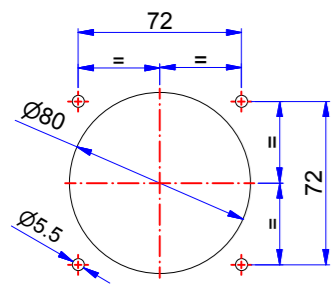

ALBERO COMANDO  
\_shaft



200 mm

Tipo_type	TS4   5	TS6   7   8   9   10
Codice_code	18201	18207

300 mm

Tipo_type	TS4   5	TS6   7   8   9   10
Codice_code	18202	18208

400 mm

Tipo_type	TS4   5	TS6   7   8   9   10
Codice_code	18203	18209

MANIGLIA DIRETTA NERA PER TS P  
\_direct interlock handle for TS P

Tipo_type	TS043P	TS046P	TS056P	TS063P	TS073P	TS083P	TS093P	TS0103P
Codice_code	18020	18588	18589	18320	18022	18023 18851	18852 18840	18852 18840

18020

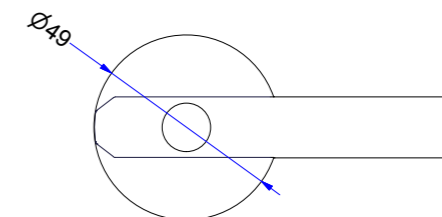
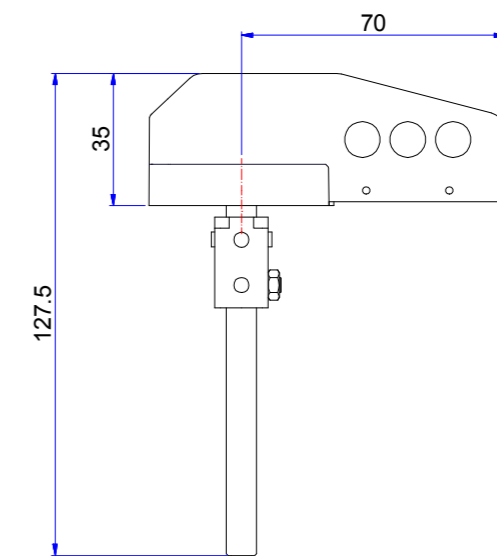



18320 - 18022 - 18023

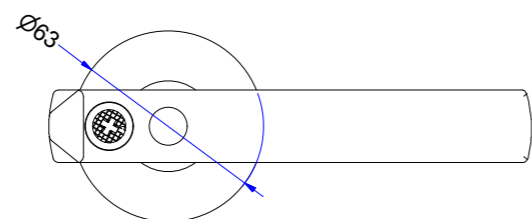
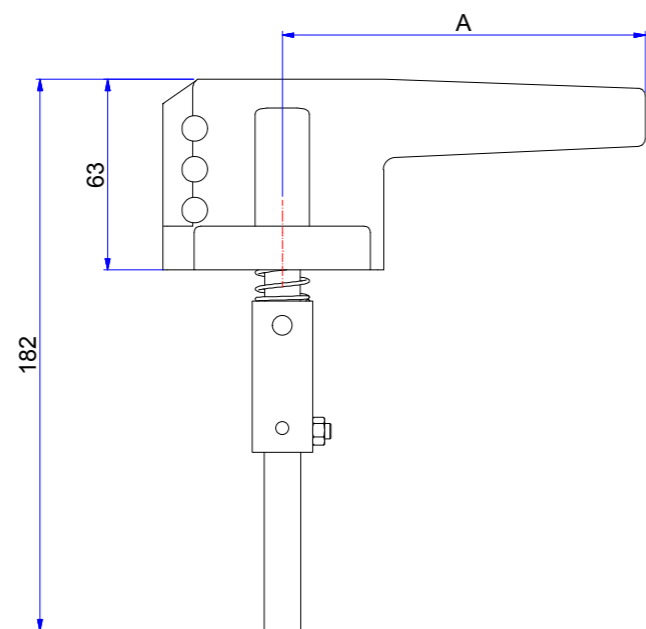

Tipo_type	A/mm
18320	120
18022	160
18023	160

18851 - 18852

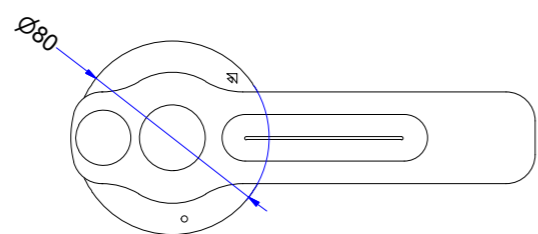
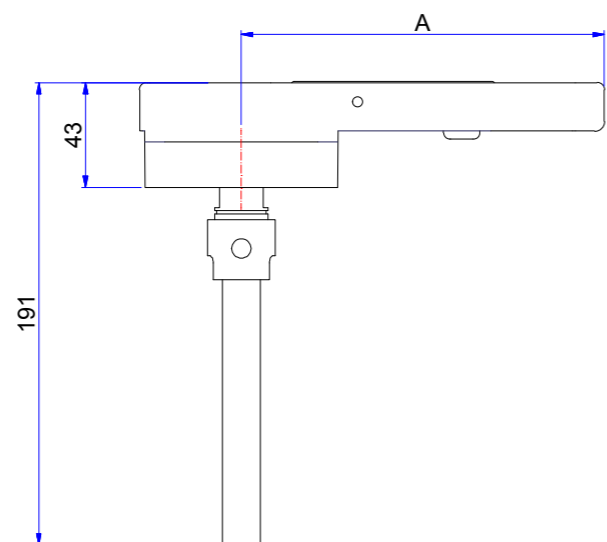
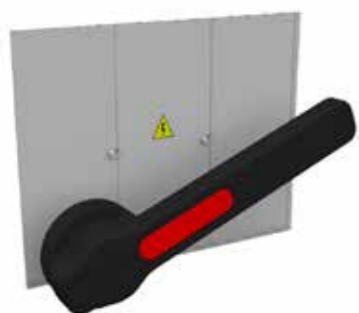

Tipo_type	A/mm
18851	150
18852	230

18840

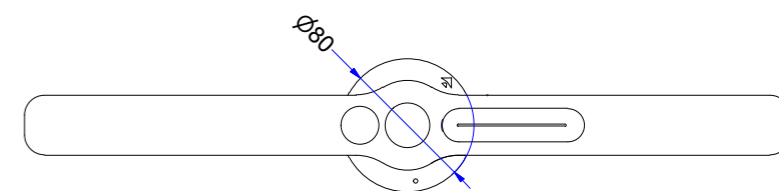
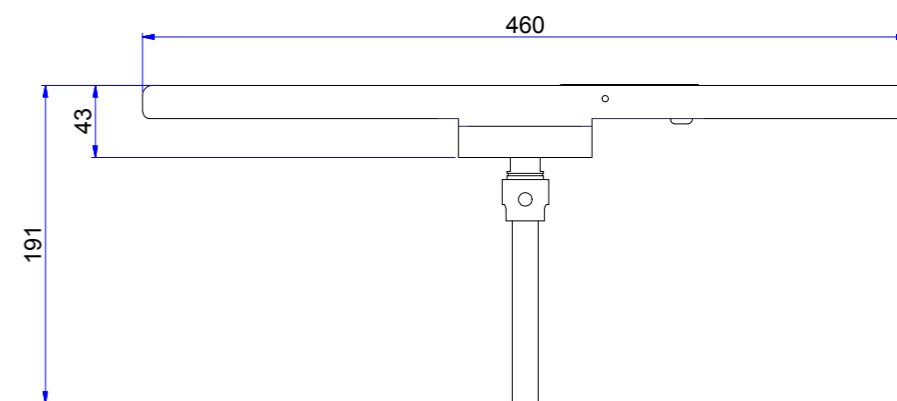

MANIGLIA DIRETTA PER TS P  
\_direct handle for TS P

Tipo_type	TS073PB	TS083PB	TS093PB	TS103PB
Codice_code	18802	18803	18803	18803

18802

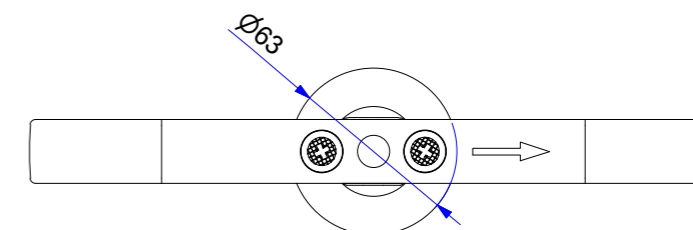
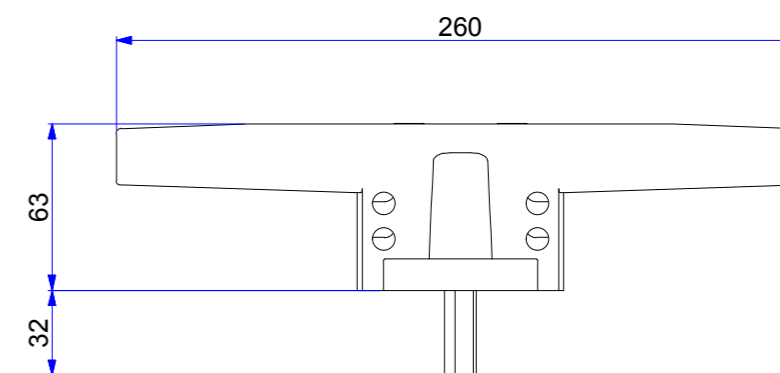

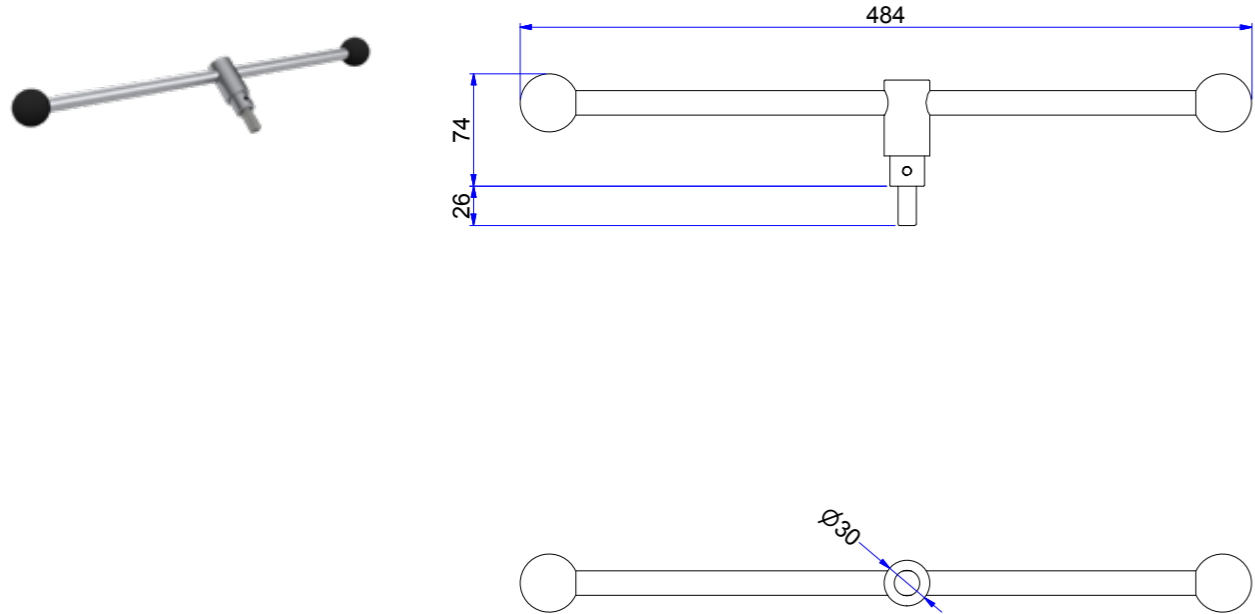

**MANIGLIA BLOCCO PORTA NERA  
CON DISPOSITIVO DI SBLOCCO CON ATTREZZO SPECIALE  
\_black door interlock handle with defeater mechanism (special tool)**

Tipo_type	TS043P	TS046P	TS056P	TS063P	TS073P	TS083P	TS093P	TS103P
Codice_code	18220	18222	18222	18222	18222	18224	18832 18850	18832 18850

**18220**

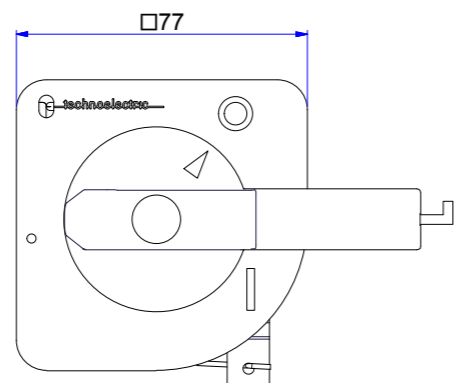
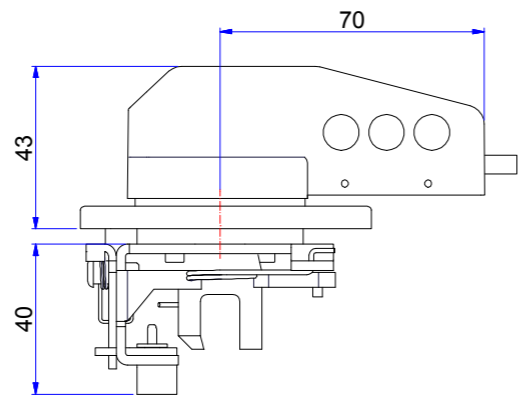

Foratura portella \_Door drilling

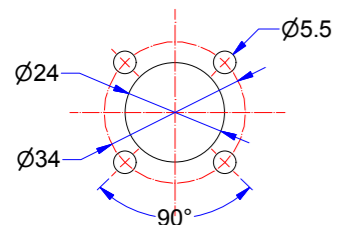

**18222**



Foratura portella \_Door drilling

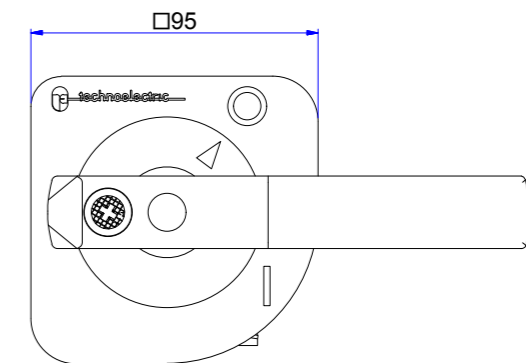
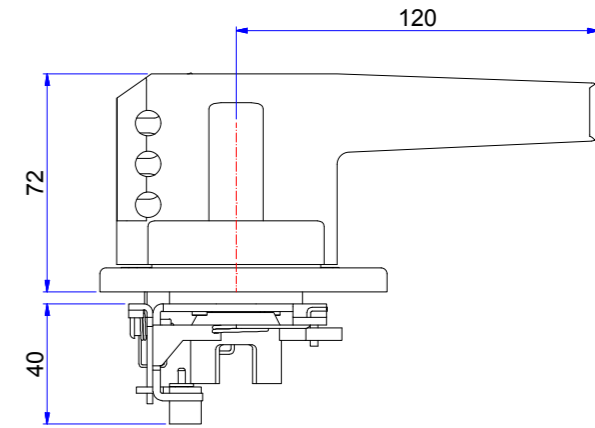
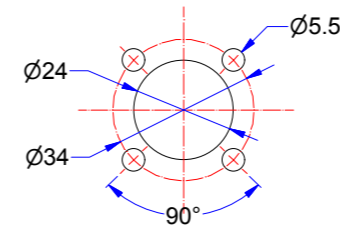

**18224**



Foratura portella \_Door drilling

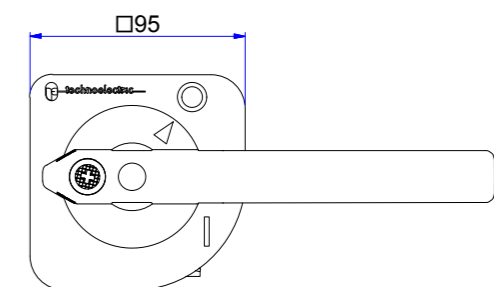
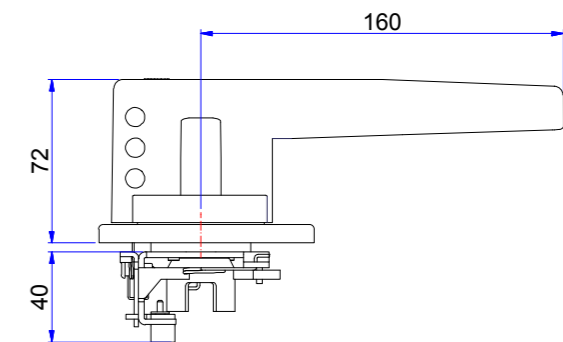
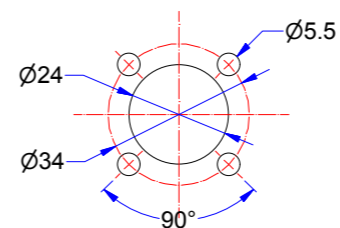

18832

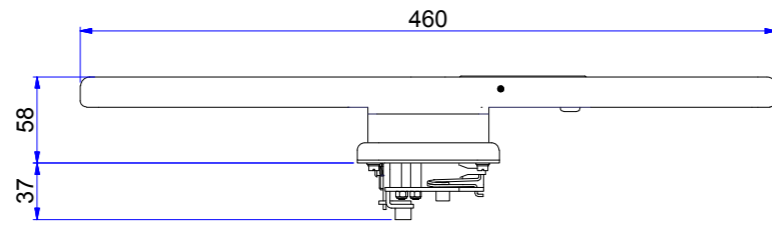

Foratura portella \_Door drilling

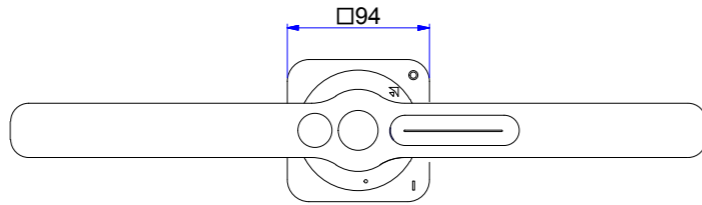
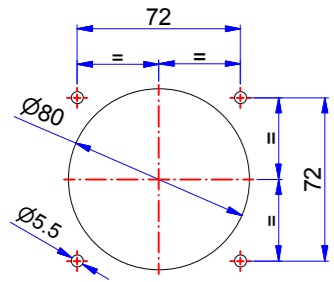

18850

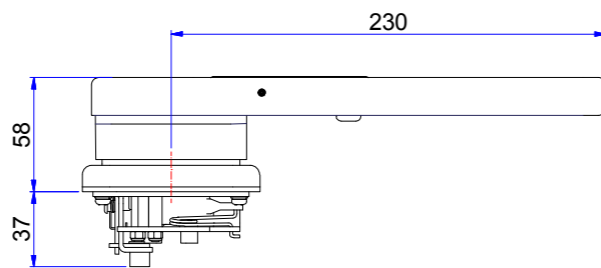

Foratura portella \_Door drilling

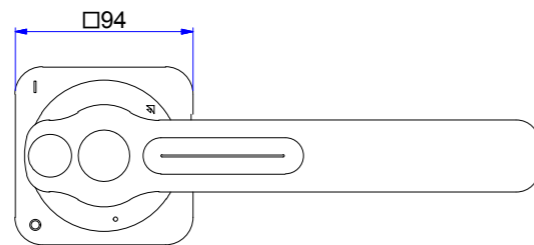
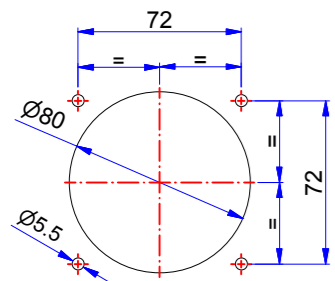

**MANIGLIA BLOCCO PORTA NERA  
CON DOPPIA FUNZIONE DI SICUREZZA PER TS P**  
\_black interlock handle with double function of security for TS P

Tipo_type	TS043P   TS046P	TS056P	TS063P	TS083P
Codice_code	18234	18234	18234	18236

18234

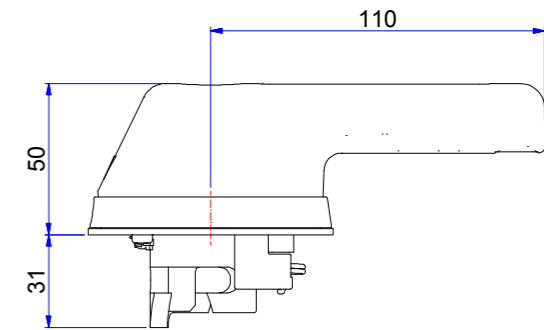

Foratura portella \_Door drilling

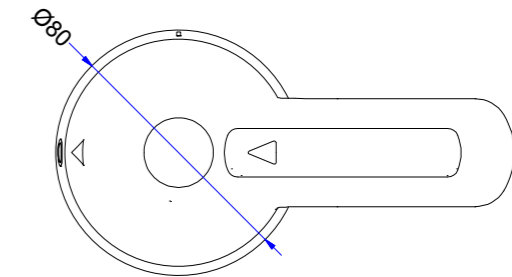
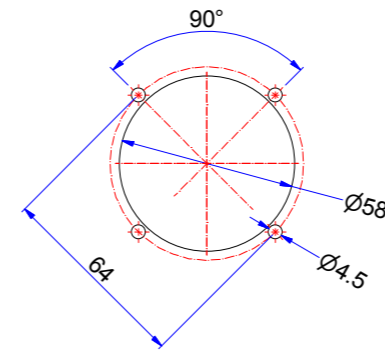

18236

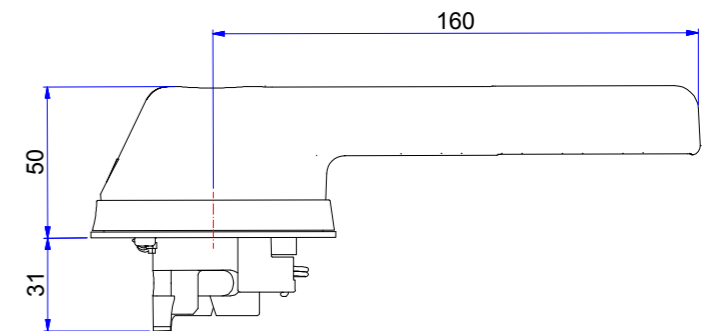

Foratura portella \_Door drilling

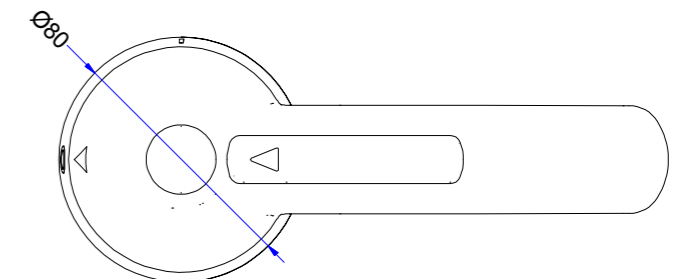
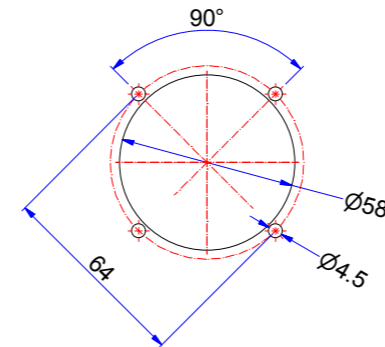

## SERIE\_TECHNOSOLAR

Adatta per montaggio su portella con dispositivo di blocco porta in posizione On Grado di protezione IP 65  
Disponibile anche nella versione per emergenza (rosso/gialla)

\_For door mounting with Door interlocking in "On" position IP 65 degree of protection  
Available also for emergency operation (red/yellow)

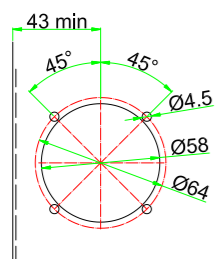
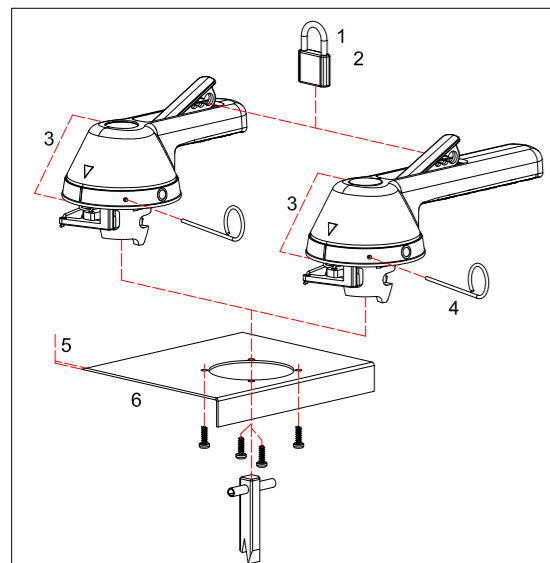

<b>1</b>	Lucchettabile (max 3 lucchetti 1xø8+2xø6) in posizione Off.	Padlockable in "Off" position (with max 3 padlocks of 1xø8+2xø6).
<b>2</b>	Apertura della portella impedita quando la maniglia è lucchettata in posizione di Off.	Door opening is prevented when the handle is padlocked in "Off" position.
<b>3</b>	Ingombro inferiore a 50 mm in profondità per permettere l'utilizzo anche in quadri a doppia portella.	Handle height less than 50 mm for suitability with two-doors type panels.
<b>4</b>	Permette, a mezzo di un apposito attrezzo, fornito con la maniglia, l'esclusione del dispositivo di blocco porta e quindi l'apertura della portella anche a interruttore in posizione di ON. Il dispositivo bloccoporta si ripristina automaticamente al chiudersi della porta.	With the use of the special tool (supplied), the door interlock mechanism can be bypassed maintaining the switch in the "On" position and the door can be opened. The door interlocking mechanism is automatically re-established when door is closed.
<b>5</b>	Può essere montata su portelle di qualsiasi spessore.	Can be mounted on doors of any thickness.
<b>6</b>	Posizione della maniglia fissa quando la portella è aperta.	When the door is open, the position of the handle is fixed

## CONTATTI AUSILIARI IN SCAMBIO 2NA + 2NC PER APERTURA ANTICIPATA

\_auxiliary contacts 2NO + 2NC  
activated before main contacts



18166

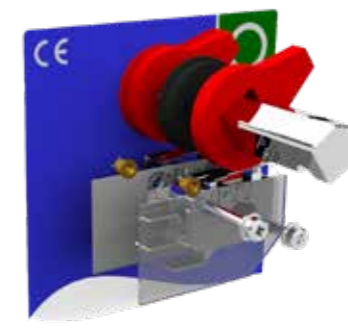

18164

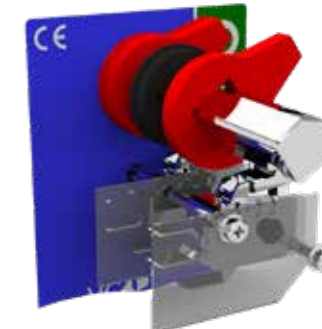

18161

Tipo_type	TS043P	TS063P	TS073P	TS083P   TS093P   TS103P
Codice_code	18166	18164	18161	18164

## CONTATTI AUSILIARI IN SCAMBIO 1NA + 1NC PER APERTURA ANTICIPATA

\_auxiliary contacts 1NO + 1NC  
activated before main contacts

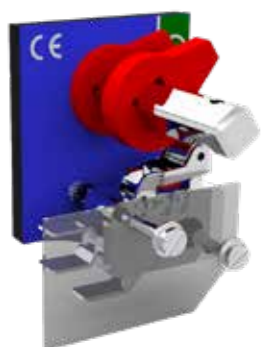

18165

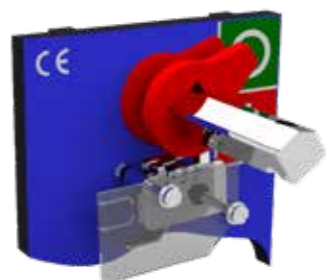

18163

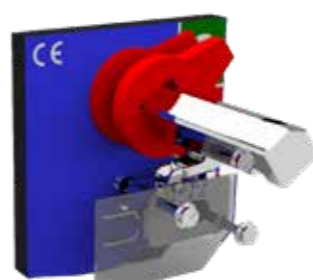

18160

Tipo_type	TS043P	TS063P	TS073P	TS083P   TS093P   TS103P
Codice_code	18165	18163	18160	18163

## CONTATTI AUSILIARI IN SCAMBIO 1NA + 1NC PER APERTURA POSTICIPATA

\_auxiliary contacts 1NO + 1NC  
activated after main contacts

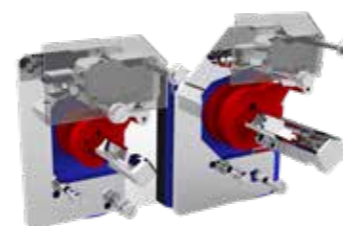

Tipo_type	TS043P	TS063P	TS073P	TS083P   TS093P   TS103P
Codice_code	18120	18127	18127	18127



**CONTATTI AUSILIARI IN SCAMBIO 2NA + 2NC**  
**PER APERTURA POSTICIPATA**  
 \_auxiliary contacts 2NO + 2NC  
 activated after main contacts

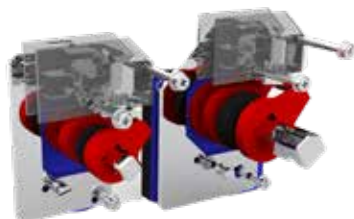

Tipo_type	TS043P	TS063P	TS073P	TS083P   TS093P   TS103P
Codice_code	18123	18128	18128	18128

Contatti ausiliari in scambio  
 Apertura anticipata rispetto  
 all'apertura dei contatti  
 principali dell'interruttore Portata  
 nominale 16A  
 Portata termica 20A

\_Change over auxiliary contacts  
 break before make contacts switches  
 Rated current 16A  
 Thermal current 20A

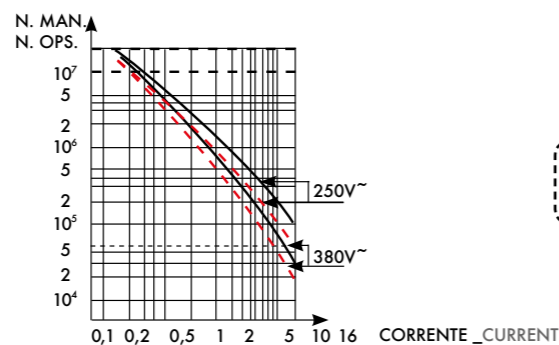

**CALOTTA PROTEZIONE TERMINALI SUPERIORI**  
 \_upper terminal cover



Tipo_type	TS043P TS046P	TS056P	TS063P	TS073P	TS083P	TS943P TS103P
Codice_code	18050	18052	18350	18054	18056	18058

**CALOTTA PROTEZIONE TERMINALI INFERIORI**  
 \_lower terminal cover

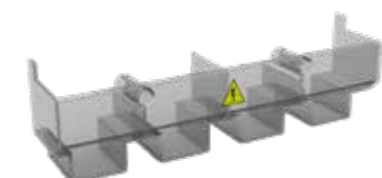

Tipo_type	TS043P TS046P	TS056P	TS063P	TS073P	TS083P	TS943P TS103P
Codice_code	18051	18053	18351	18055	18057	18059

**CONTATTI AUSILIARI IN SCAMBIO 1NA+1NC**  
 \_auxiliary contacts 1NO+1NC



Tipo_type	TS046P	TS056P
Codice_code	18566 (plettina_lever)	

**SCHERMO PROTEZIONE CONTATTI PRINCIPALI**  
 \_main contacts cover shield

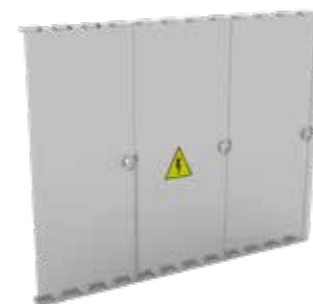

Tipo_type	TS043P TS046P	TS056P	TS063P	TS073P	TS083P	TS943P TS103P
Codice_code	18060	18061	18360	18062	18063	18063

**CONTATTI AUSILIARI IN SCAMBIO 2NA+2NC**  
 \_auxiliary contacts 2NO+2NC



Tipo_type	TS046P	TS056P
Codice_code	18568	

**SPESSORE RIALZO**  
\_risers



Tipo _type	TS043P TS046P	TS056P	TS063P	TS073P	TS083P	TS943P TS103P
Codice _code	18290	18291	18292	18293	18293	18293

Tipo _type	h/mm	Ø	Confezione da 4pz. _4pcs pack
VC1	5	15	
VC2	5	18	
VC3	10	17	
VC4-5	15	24	



# **INTERRUTTORI, SEZIONATORI MODULARI CON E SENZA PORTAFUSIBILI**

**\_SWITCH DISCONNECTORS  
WITH AND WITHOUT FUSE**

**GT 630 ÷ 4000 A**



## SERIE\_SERIES GT

### GENERALITÀ

Gli interruttori di manovra sezionatori GT-GLOBE TECHNICS con e senza porta fusibili, consentono l'apertura e la chiusura sotto carico di circuiti elettrici in bassa tensione.

### IMPIEGO

Sono normalmente impiegati nelle seguenti funzioni:  
 interruttore generale  
 interruttore per motori  
 interruttore sezionatore  
 interruttore di sicurezza

Con la versione dotata di porta fusibile tipo GT-FP e specifici fusibili, svolge le funzioni di protezione contro i corto circuiti e il sovraccarico di impianti e macchine.

### CARATTERISTICHE GENERALI

Tensione di isolamento nominale 1500v c.A. e 1500v c.C.  
 Disponibili 2-3-4 poli  
 Il polo di fase e quello del comando possono essere collocati in qualsiasi posizione  
 Terminali con attacchi frontali, posteriori o con combinazioni di entrambi  
 Alto potere di interruzione (AC22, AC23, IEC 60947-3)  
 Elevata durata meccanica ed elettrica  
 Doppia interruzione per polo (con porta fusibili)  
 Porta fusibili isolati su entrambi i lati con interruttore aperto  
 Possibilità di montaggio fusibili DIN-BS  
 Contatti autopulenti  
 La posizione della maniglia costituisce una indicazione positiva e affidabile della posizione dei contatti  
 Visibilità diretta mediante opportune feritoie, dei contatti fissi e mobili  
 Manovra a scatto rapido indipendente può essere frontale o laterale  
 Disponibile versione con polo di neutro passante  
 Neutro a piena corrente  
 Protezione adeguata per prevenire i contatti accidentali  
 Involucro in materiali autoestinguenti (classe VO-UL94) a bassa igroscopicità, ad alta resistenza meccanica e alle correnti superficiali  
 Adatto per l'utilizzo in climi tropicali  
 Maniglia esterna a doppio isolamento con blocco porta in pos. 1 Grado di protezione IP65, possibilità di 3 blocchi con lucchetto in posizione 0  
 Maniglia diretta lucchettabile in posizione di zero  
 Albero di comando telescopico  
 Contatti aux di segnalazione (max 4NA+4NC) + contatti di pre-apertura (max 2NA+2NC)  
 Vasta gamma di accessori

### CONDIZIONI NORMALI DI SERVIZIO, MONTAGGIO E TRASPORTO

Temperatura ambiente di immagazzinamento e trasporto - 25°C + 55°C  
 Temperatura ambiente di funzionamento - 20°C + 40°C  
 In caso di temperatura ambiente ( $t_a$ ) superiore, applicare la seguente formula di declassamento:

$$I_{the} = k I_{th} \text{ dove } k = 1 - \frac{t_a - 40}{100}$$

Umidità relativa max 95%  
 Frequenza nominale 50 - 60 hz  
 Altitudine max 2000 m s.l.m.  
 Grado di inquinamento 3 secondo IEC 60947-1  
 Montaggio in custodia: in caso di utilizzo a piena corrente e in mancanza di adeguata ventilazione assicurare un volume pari a circa 5 volte quello dell'apparecchio  
 Tipo di servizio (secondo IEC 60947-1): 8 ore; ininterrotto; intermittente 60% classe 30; temporaneo; periodico.  
 Per condizioni di impiego diverse consultare il costruttore.

### CONFORMITÀ ALLE NORME

IEC 60947-1 | IEC 60947-3 | UNI EN 60947-1 | UNI EN 60947-3 | EAC

### CERTIFICATI E OMOLOGAZIONI

IENGF

### GENERALITIES

The switch disconnecter GT-GLOBE TECHNICS with and without fuses are suitable for making and breaking on load and disconnecting low voltage electrical circuits.

### USE

GT switches commonly used for the following purposes:  
 main switch  
 switch for motors  
 switch disconnecter  
 safety switch

The version type GT-FP with fuses it carry out the protection functions against the short circuits and overload system and machines

### GENERAL CHARACTERISTICS

Rated insulation voltage 1500V AC and 1500V DC  
 2-3-4 Poles available  
 Each phase, pole phase and the operating mechanism can be mounted in any position  
 Terminals with front or rear connections or with both combination  
 High breaking capacity (AC22, AC23, IEC 60947-3)  
 High electrical and mechanical endurance  
 Double break contacts (with fuse)  
 Totally insulated when opened switch  
 Suitable for din-bs fuses  
 Self cleaning contacts  
 Contact position positively indicated by the handle  
 Visibility of fixing and moving contacts by means of windows  
 Side and frontal independent manual operation  
 Solid neutral version available  
 Full neutral current  
 Suitable protection to prevent accidental touching of the live parts  
 Casing in self-extinguishing (vo-ul94), low hygrosopic and high mechanical  
 Resistance isolating material  
 Resistant to damp heat  
 External double insulated handle with door interlock in ON position, IP65 degree of protection, padlockable with three padlocks in off position  
 Direct handle padlockable in off position  
 Adjustable shaft  
 Max 4NO+4NC auxiliary signaling contacts and max 2NO+2NC pre-break auxiliary contacts  
 Wide range of accessories

### NORMAL SERVICE, MOUNTING AND TRANSPORT CONDITIONS

Storage and transport ambient temperature - 25°C + 55°C  
 Working ambient temperature - 20°C + 40°C  
 In case of higher ambient temperature ( $t_a$ ) consider the following derating formula:

$$I_{the} = k I_{th} \text{ where } k = 1 - \frac{t_a - 40}{100}$$

Relative humidity max 95%  
 Rated frequency 50 - 60 hz  
 Altitude max 2000 m a.s.l.  
 Pollution degree 3 according IEC 60947-1  
 Mounting in enclosure: in case of utilisation at full load and without adequate ventilation, ensure a volume of about 5 times the volume of the switch  
 Duty (IEC 60947-1): 8 hours; uninterrupted; intermittent 60% class 30; temporary; periodic.

For different operating conditions, please contact the manufacturer.

### CONFORMITY TO STANDARDS

IEC 60947-1 | IEC 60947-3 | UNI EN 60947-1 | UNI EN 60947-3 | EAC

### CERTIFICATES AND APPROVALS

IENGF

## Configurazione standard Standard configuration



Tipo _type	Corrente nominale _rated current	POLI _POLES	CODICE _CODES
<b>GT5 PN</b>	800A	3	GT5000
		4	GT5010
	1000A	3	GT5001
		4	GT5011
	1250A	3	GT5002
		4	GT5012
<b>GT6 PN</b>	1600A	3	GT6000
		4	GT6010
	2000A	3	GT6001
		4	GT6011
	2500A	3	GT6002
		4	GT6012
3150A	3	GT6003	
	4	GT6013	
4000A	3	GT6004	
	4	GT6014	
<b>GT5 FP NH3-DIN</b>	630A	3	GT5020
		4	GT5030
	800A	3	GT5022
		4	GT5032
<b>GT5 FB C3-BS88</b>	630A	3	GT5040
		4	GT5050
	800A	3	GT5041
		4	GT5051
<b>GT6 FP NH4-DIN</b>	1000A	3	GT6020
		4	GT6030
	1250A	3	GT6021
		4	GT6031
<b>GT6 FB D1-BS88</b>	1000A	3	GT6040
		4	GT6050
	1250A	3	GT6041
		4	GT6051

CODICI DI ORDINAZIONE COMMUTATORI  
 Aggiungere cifra 3 a fine codice per orizzontali e cifra 8 per sovrapposti

\_ORDERS REFERENCES FOR CHANGE OVER  
 Add number 3 at the end of code for horizontal type, number 8 for double layer type





CODICI DI ORDINAZIONE COMMUTATORI  
Aggiungere cifra 3 a fine codice per orizzontali  
e cifra 8 per sovrapposti

\_ORDERS REFERENCES FOR CHANGE OVER  
Add number 3 at the end of code for horizontal  
type, number 8 for double layer type

Tipo _type	Corrente nominale _rated current	POLE _POLES	CODICE _CODES	
<b>GT5 PN</b>	800A	3	GT5000CL	
		4	GT5010CL	
	1000A	3	GT5001CL	
		4	GT5011CL	
	1250A	3	GT5002CL	
		4	GT5012CL	
<b>GT6 PN</b>	1600A	3	GT6000CL	
		4	GT6010CL	
	2000A	3	GT6001CL	
		4	GT6011CL	
	2500A	3	GT6002CL	
		4	GT6012CL	
	3150A	3	GT6003CL	
		4	GT6013CL	
	4000A	3	GT6004CL	
		4	GT6014CL	
	<b>GT5 FP NH3-DIN</b>	630A	3	GT5020CL
			4	GT5030CL
800A		3	GT50224CL	
		4	GT5032CL	
<b>GT5 FB C3-BS88</b>	630A	3	GT5040CL	
		4	GT5050CL	
	800A	3	GT5041CL	
		4	GT5051CL	
<b>GT6 FP NH4-DIN</b>	1000A	3	GT6020CL	
		4	GT6030CL	
	1250A	3	GT6021CL	
		4	GT6031CL	
<b>GT6 FB D1-BS88</b>	1000A	3	GT6040CL	
		4	GT6050CL	
	1250A	3	GT6041CL	
		4	GT6051CL	

Caratteristiche tecniche _Technical Features	Tipo _Type	GT5 PN									GT6 PN					
		In	A	800	1000	1250	1600	2000	2500	3150	4000	GT5 FP NH3- DIN	GT5 FB C3- BS88	GT6 FP NH4- DIN	GT6 FB D1- BS88	GT6 FP NH4- DIN
Corrente nominale _Rated current	In	A	800	1000	1250	1600	2000	2500	3150	4000	630	800	1000	1000	1250	1250
Tensione nominale d'isolamento _Rated insulation voltage	Ui	V	1500	1500	1500	1500	1500	1500	1500	1500	1500	1500	1500	1500	1500	1500
Corrente nominale termica _Thermal current	Ith	A	800	1000	1250	1600	2000	2500	3150	4000	630	800	1000	1000	1250	1250
Corrente nominale d'impiego _Rated operational current																
AC-21A	420V	A	800	1000	1250	1600	2000	2500	3150	4000	630	800	1000	1000	1250	1250
	500V	A	800	1000	1250	1600	2000	2500	3150	4000	630	800	1000	1000	1250	1250
	690V	A	800	1000	1250	1600	-	-	-	-	630	800	1000	1000	1250	1250
AC-22A	420V	A	800	1000	1250	1600	2000	2500	-	-	630	800	1000	1000	1250	1250
	500V	A	800	1000	1250	1600	2000	2500	-	-	630	800	1000	1000	1250	1250
	690V	A	800	1000	1250	1600	-	-	-	-	630	800	1000	1000	1250	1250
AC-23A	420V	A	800	1000	1250	1600	1250	1250	-	-	630	800	1000	1000	1250	1250
	500V	A	800	1000	1250	1200	1000	1000	-	-	630	800	1000	1000	1250	1250
	690V	A	800	800	800	1000	-	-	-	-	630	800	1000	1000	1250	1250
Corrente di breve durata _Short-circuit withstand current	1 sec	kA	40	40	40	50	50	50	50	50	-	-	-	-	-	-
Potere di chiusura in corto circuito _Short-circuit making capacity	400V	kA	84	84	84	105	105	105	105	105	-	-	-	-	-	-
Corrente di corto circuito condizionata da fusibile _Rated fuse short-circuit current																
Tipo fusibile _Backup fuse		A	800	1000	1250	-	-	-	-	-	630	800	1000	1000	1250	1250
Valore efficace _R.M.S. value		kA	100	100	100	-	-	-	-	-	100	100	100	100	100	100
Valore di picco _Peak value		kA	50	60	70	-	-	-	-	-	40	50	60	60	70	70
Durata meccanica _Mechanical endurance		n.	4000	4000	4000	4000	2500	2500	2500	2500	4000	4000	4000	4000	4000	4000
Durata elettrica _Electrical endurance		n.	1000	1000	1000	1000	500	500	500	500	1000	1000	1000	1000	1000	1000
Potenza dissipata per polo _Power losses for pole		W	12	20	78	128	80	125	170	272	36	58	90	90	140	140
Potenza condensatori _rated capacitor power	400V	KVAR	380	475	600	780	850	1100	1250	1600	300	380	475	475	600	600
Peso netto _Net weight	3P	Kg	15	16	36	36	40	40	80	80	15	15	36	36	36	36
	4P		19,5	20,5	46	46	50	50	100	100	19,5	19,5	46	46	46	46

**GT5PN 800 ÷ 1000 A 3P**

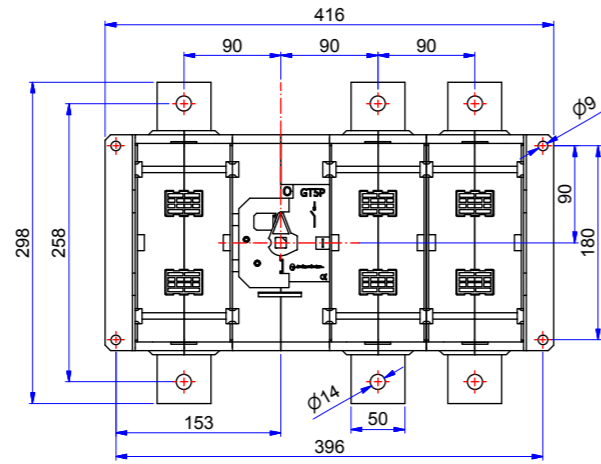

Foratura portella \_Door drilling

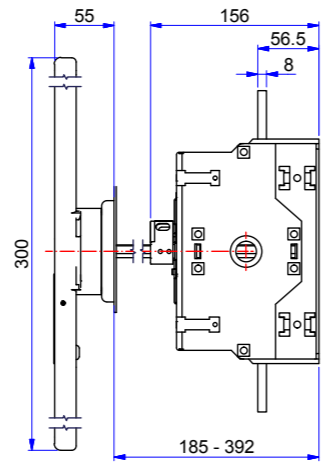
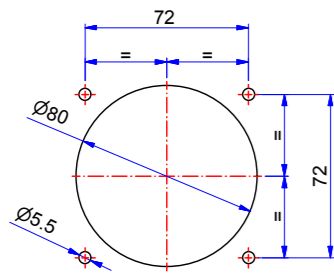

**GT6PN 1600 A 3P**

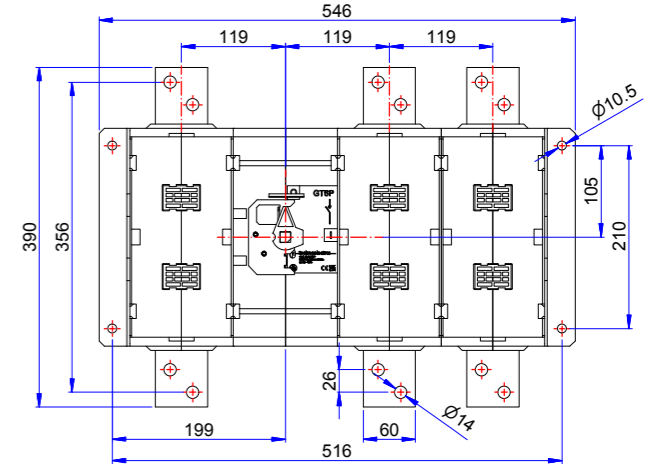

Foratura portella \_Door drilling

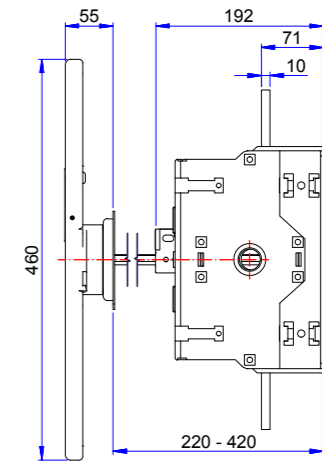
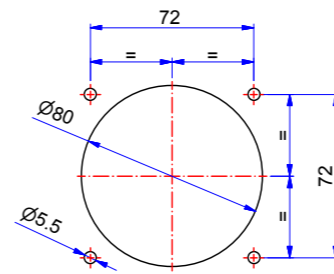

**GT5PN 1250 A 3P**

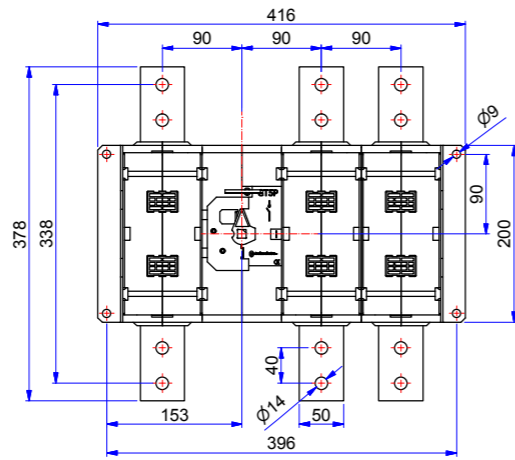

Foratura portella \_Door drilling

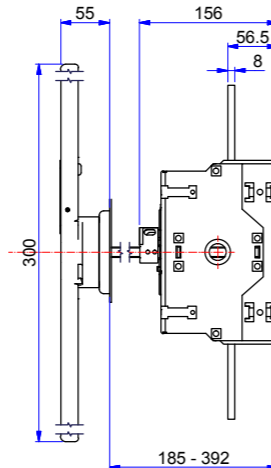
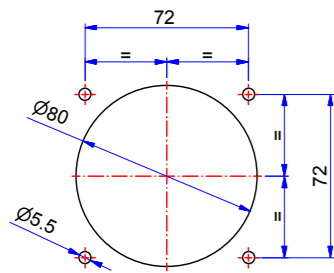

**GT6PN 2000 ÷ 2500 A 3P**

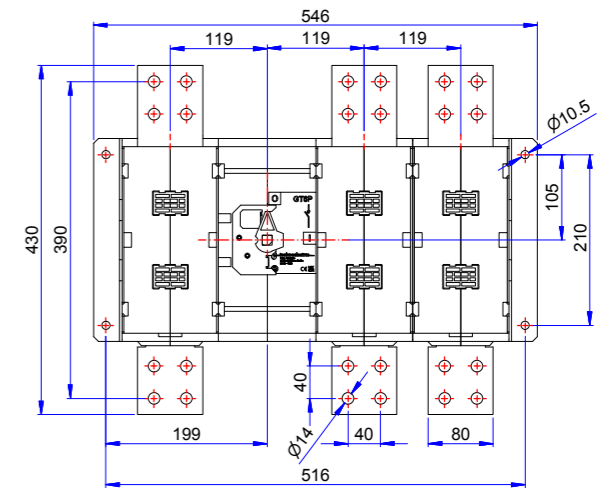

Foratura portella \_Door drilling

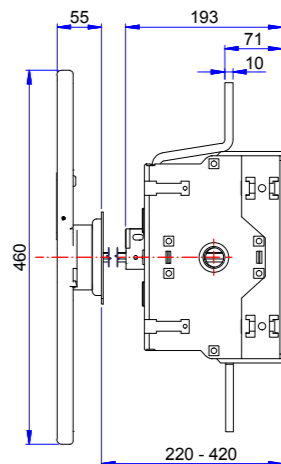
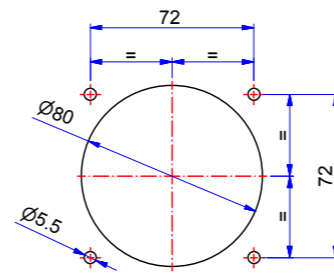

**GT6PN 3150 ÷ 4000 A 3P**

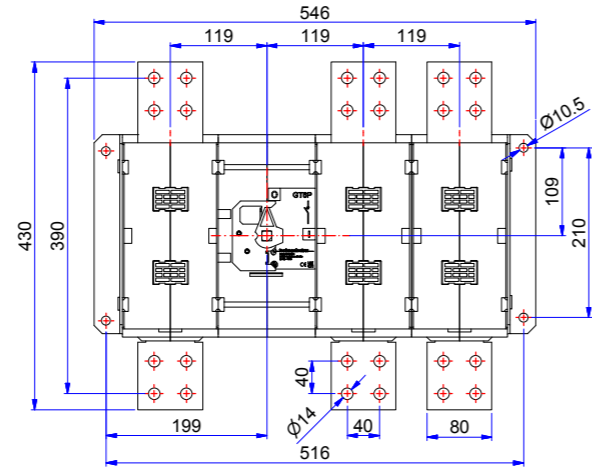

Foratura portella \_Door drilling

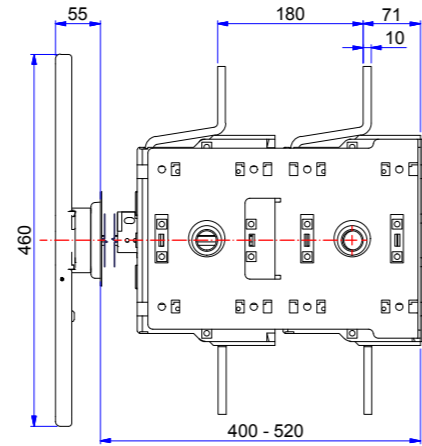
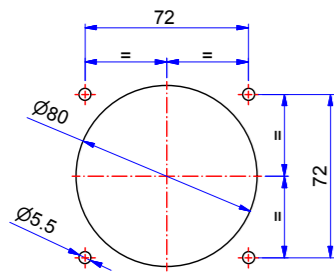

**GT5PN 1250 A 4P**

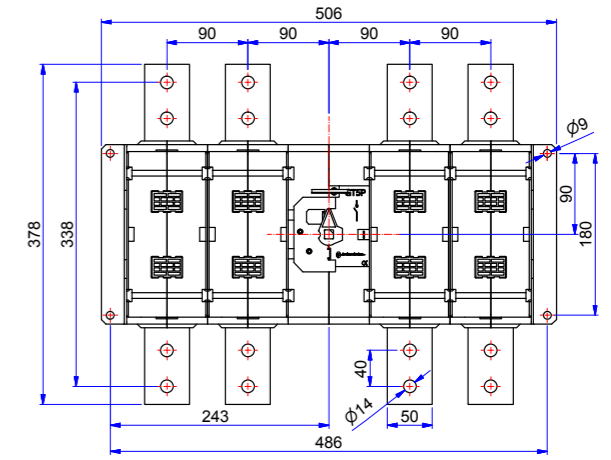

Foratura portella \_Door drilling

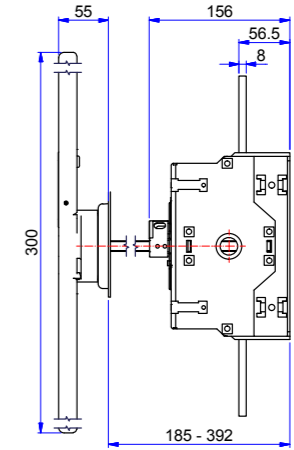
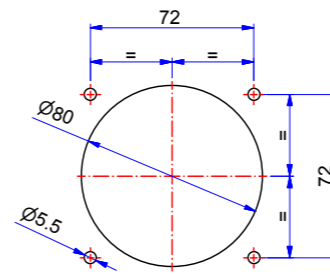

**GT5PN 800 ÷ 1000 A 4P**

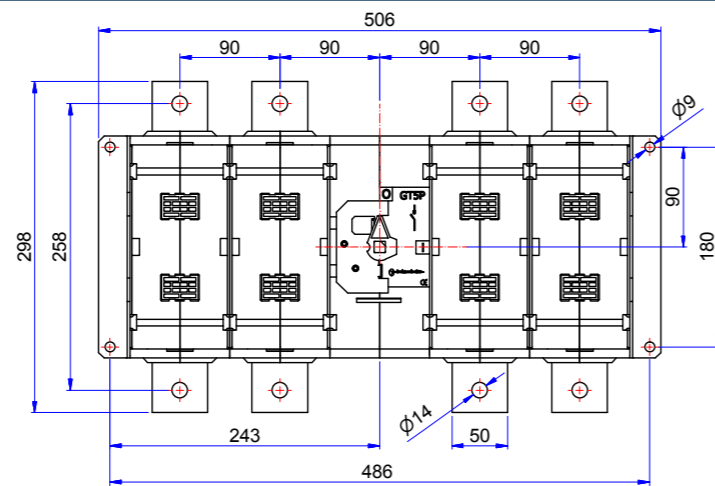

Foratura portella \_Door drilling

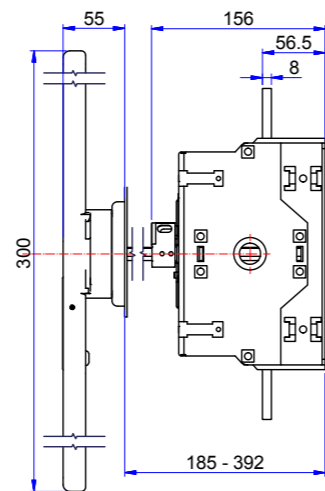
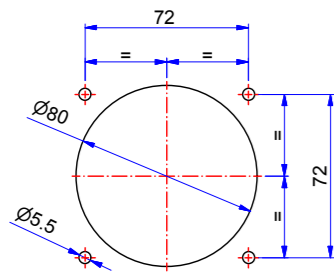

**GT6PN 1600 A 4P**

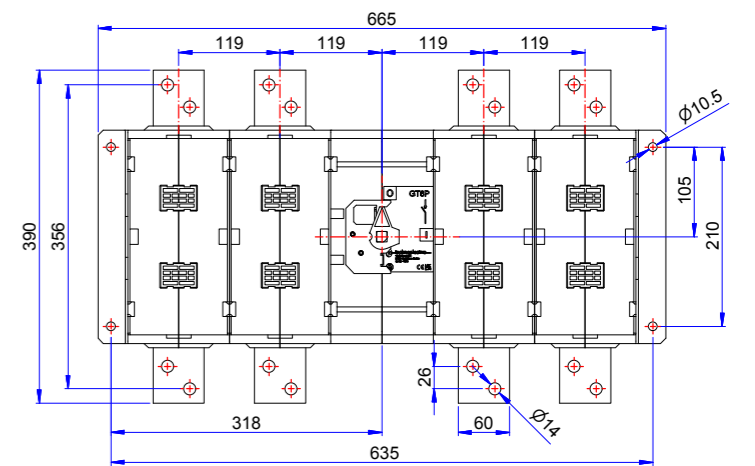

Foratura portella \_Door drilling

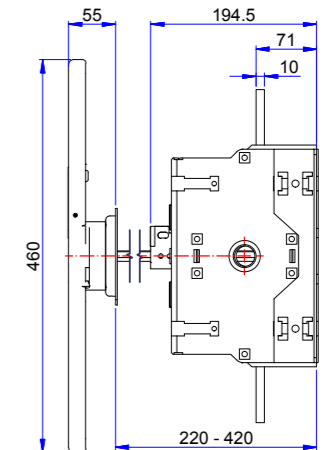
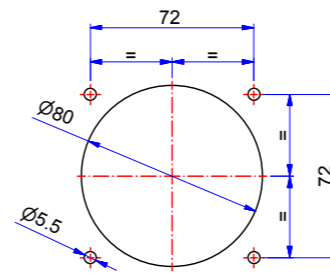

**GT6PN 2000 ÷ 2500 A 4P**

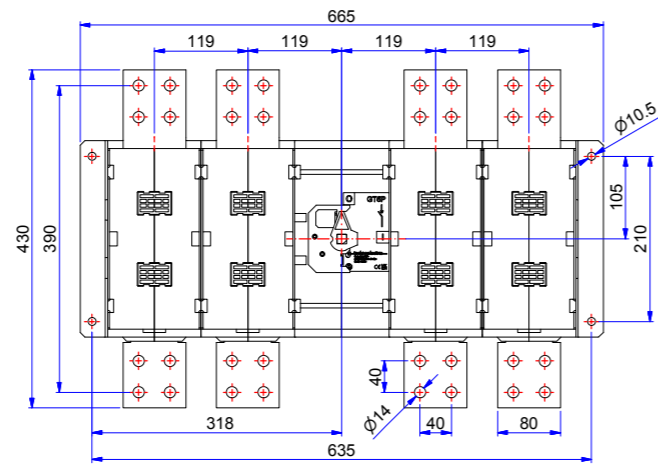

Foratura portella \_Door drilling

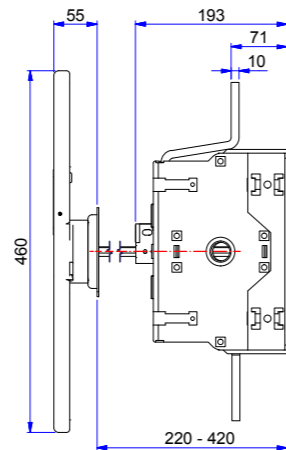
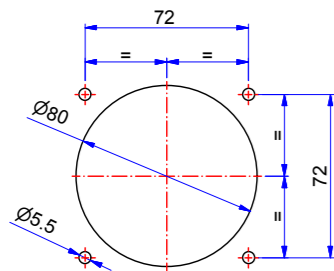

**GT5FP-B 630 ÷ 800 A 3P**

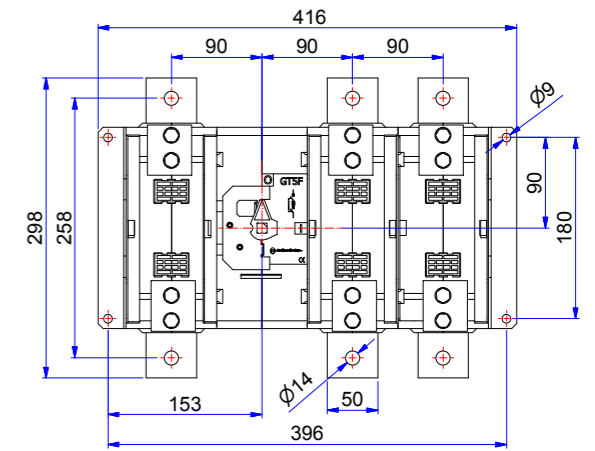

Foratura portella \_Door drilling

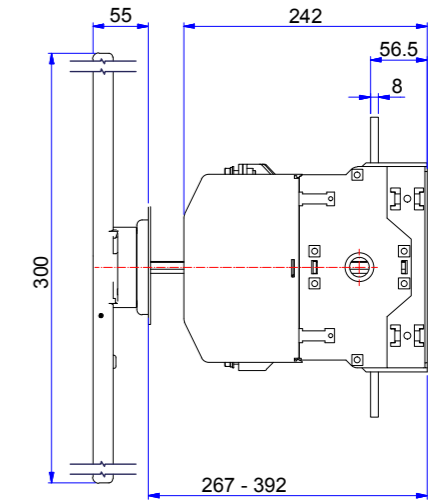
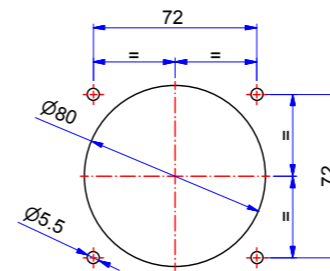

**GT6PN 3150 ÷ 4000 A 4P**

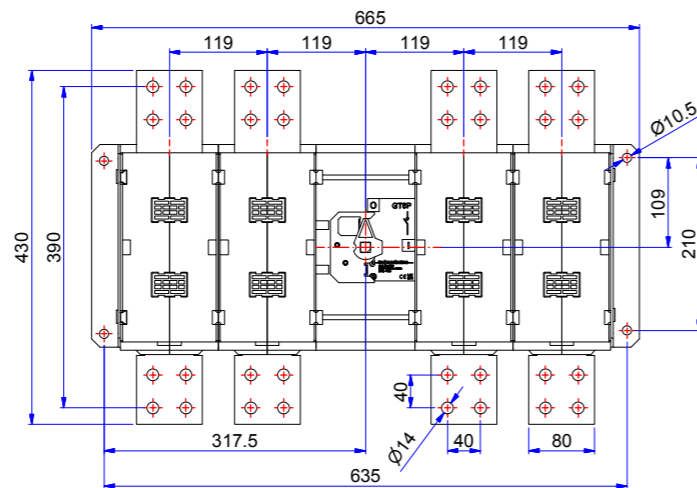

Foratura portella \_Door drilling

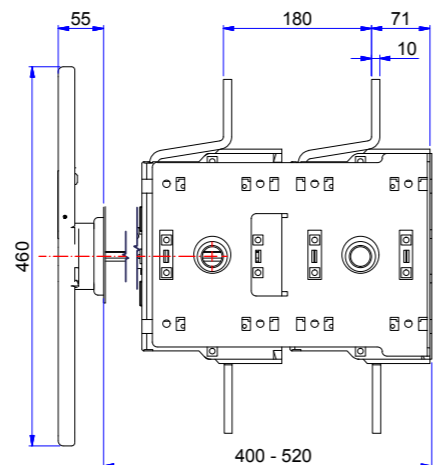
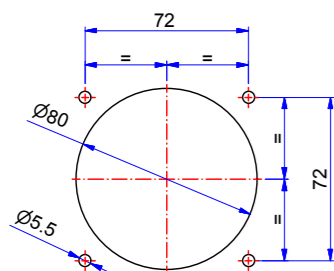

**GT6FP-B 1000 ÷ 1250 A 3P**

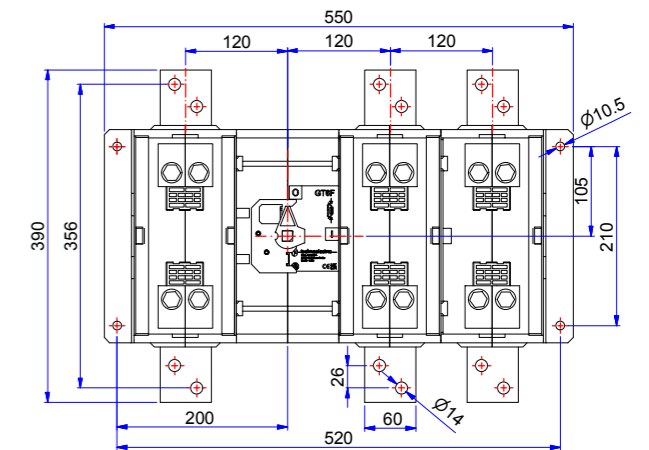

Foratura portella \_Door drilling

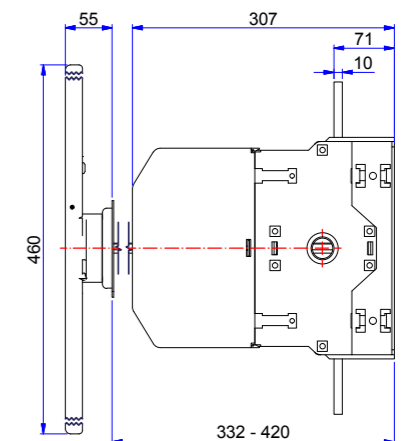
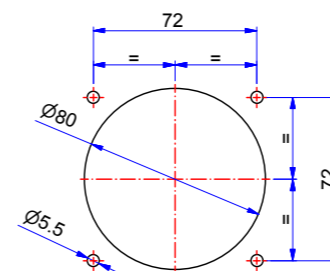



**GT5FP-B 630 ÷ 800 A 4P**

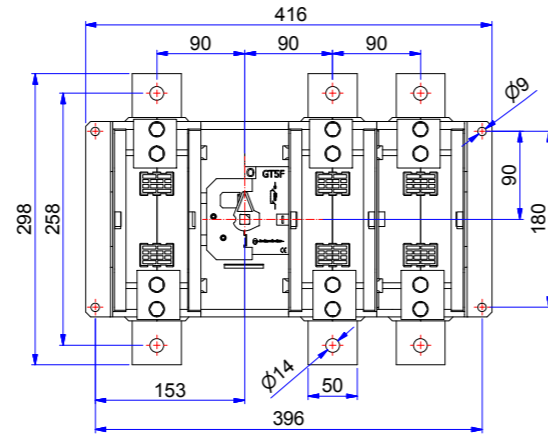
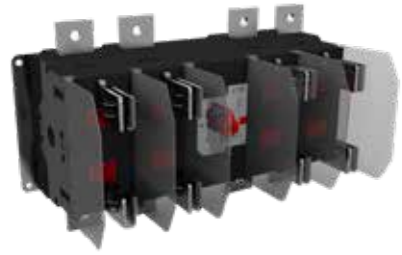

Foratura portella \_Door drilling

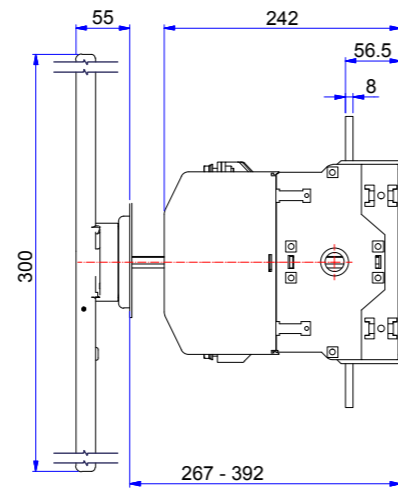
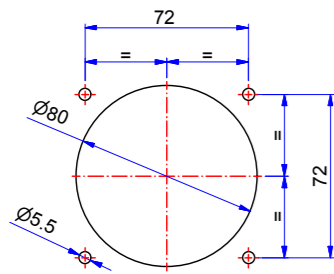

**GT5P CL 3P**  
**Comando laterale \_side operation**

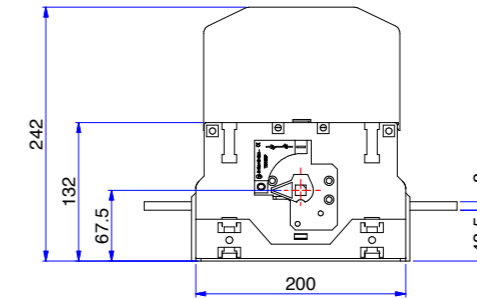
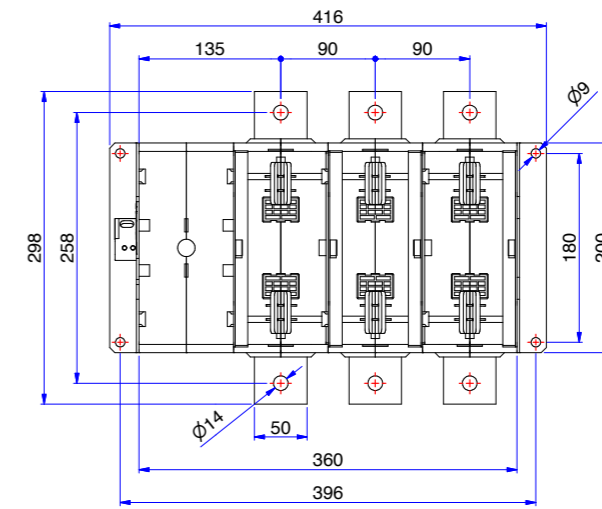

**GT6FP-B 1000 ÷ 1250 A 4P**

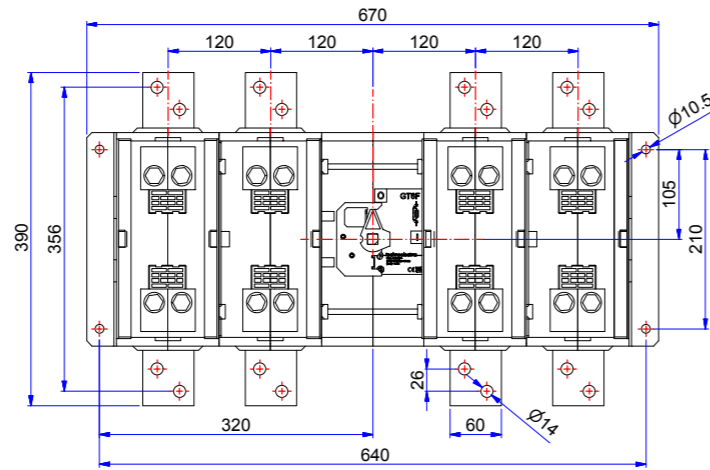

Foratura portella \_Door drilling

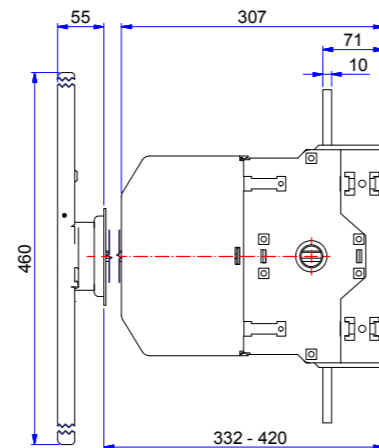
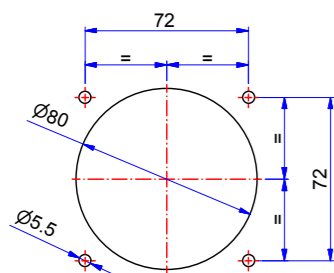

**GT5P CL 4P**  
**Comando laterale \_side operation**

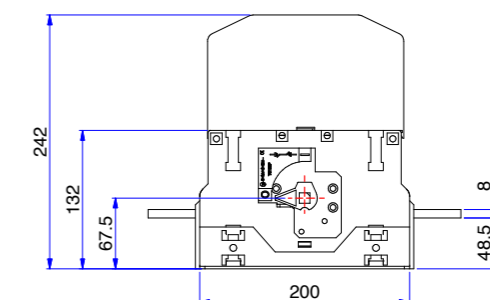
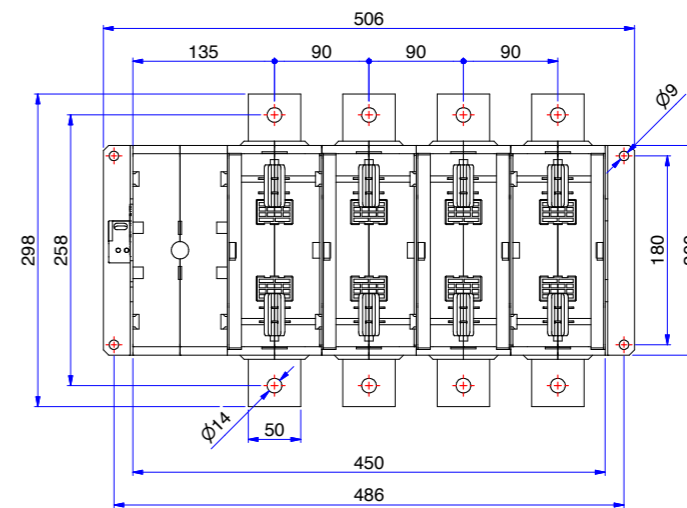

**GT6P CL 3P**  
**Comando laterale \_side operation**

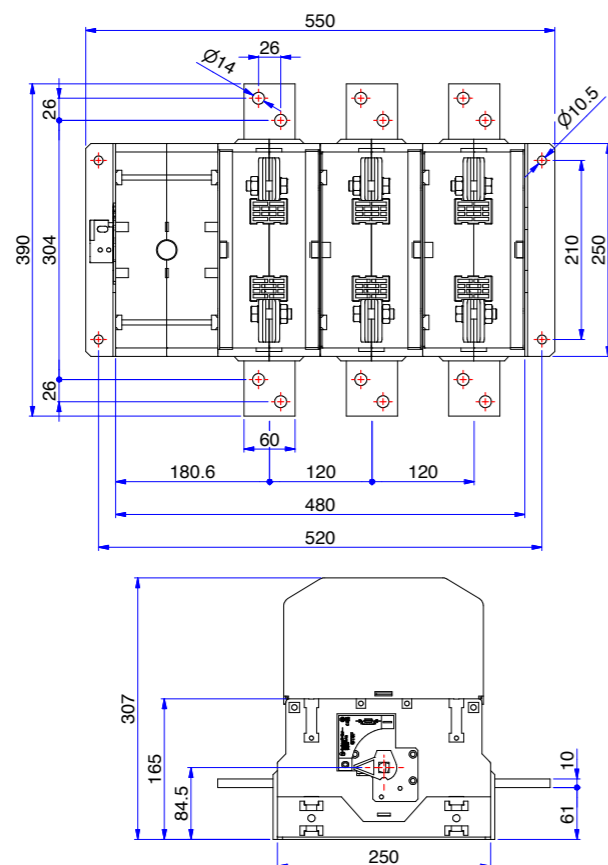

**GT6P CL 4P**  
**Comando laterale \_Side operation**

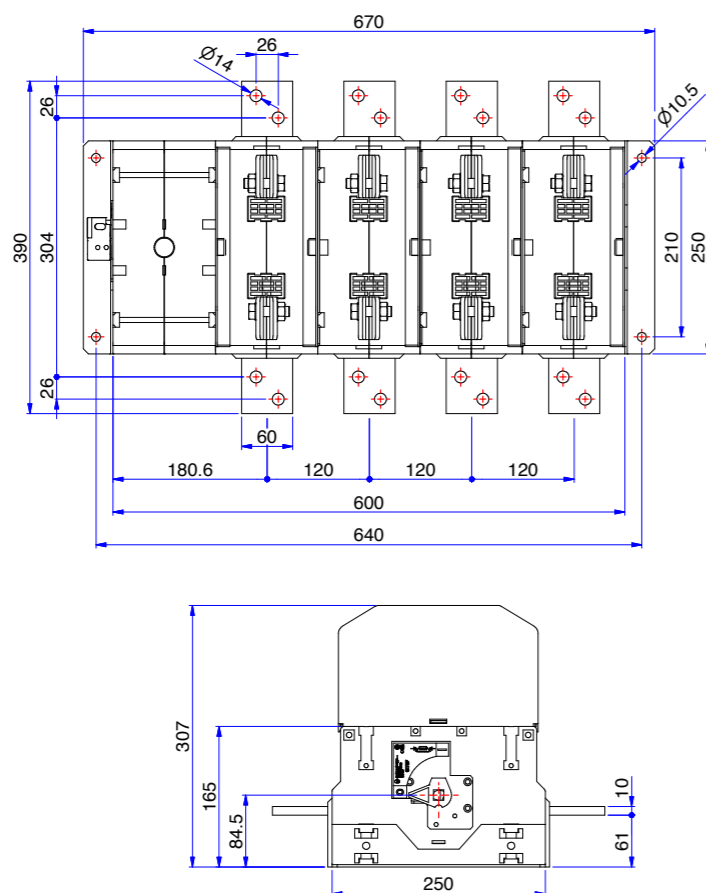

**SEPARATORI FUSIBILI**  
**\_fuse separators**



Tipo_type	GT5	GT6
Codice_code	GA5401	GA6401

**SCHERMO PROTEZIONE FUSIBILI**  
**\_fuse cover**



Tipo_type	GT5	GT6
Codice_code	GA5301-3	GA6301-3

**COPRI TERMINALI**  
**\_terminal covers**



Tipo_type	GT5	GT6
Codice_code	GA5302-3 GA5302-4	GA6302-3 GA6302-4

**CONTATTI AUSILIARI DI PREAPERTURA 1NA + 1NC**  
**\_break before make auxiliary contacts 1NO + 1NC**



Tipo_type	GT5	GT6
Codice_code	GA6205	

**CONTATTI AUSILIARI DI PRE-APERTURA 3NA + 3NC**  
**\_break before make auxiliary contacts 3NO + 3NC**



Tipo_type	GT5	GT6
Codice_code	GA6206	

SERIE\_SERIES GT

**CONTATTI AUSILIARI 1NA + 1NC**  
**\_auxiliary contacts 1NO + 1NC**



Tipo_type	GT5	GT6
Codice_code	GA5201	GA6201

**CONTATTI AUSILIARI 2NA + 2NC**  
**\_auxiliary contacts 2NO + 2NC**



Tipo_type	GT5	GT6
Codice_code	GA5202	GA6202

**CONTATTI AUSILIARI 3NA + 3NC**  
**\_auxiliary contacts 3NO + 3NC**



Tipo_type	GT5	GT6
Codice_code	GA5203	GA6203

**CONTATTI AUSILIARI 4NA + 4NC**  
**\_auxiliary contacts 4NO + 4NC**



Tipo_type	GT5	GT6
Codice_code	GA5204	GA6204

**ALBERO COMANDO**  
**\_shaft**



300 mm

Tipo_type	GT5	GT6
Codice_code	GA5103	GA6103

400 mm

Tipo_type	GT5	GT6
Codice_code	GA5104	GA6104

**MANIGLIA DOPPIA BLOCCO PORTA**  
**\_door interlock double handle**

Tipo_type	GT5	GT6
Codice_code	GA6001	GA6016

Albero di comando standard lunghezza 300 mm incluso in ogni confezione  
 \_Standard shaft length 300 mm included into the package

**GA6001**

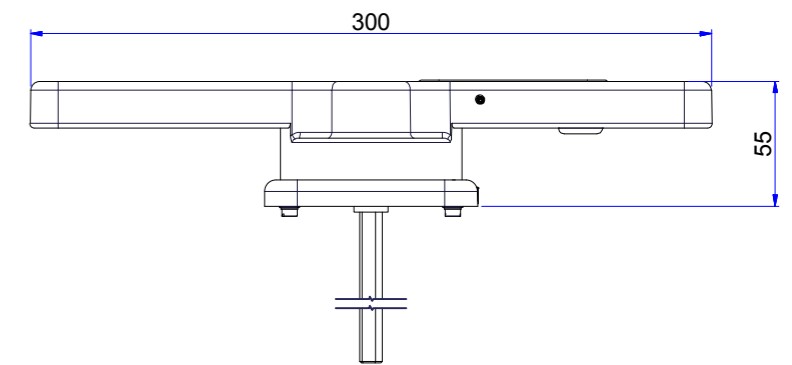

Foratura portella \_Door drilling

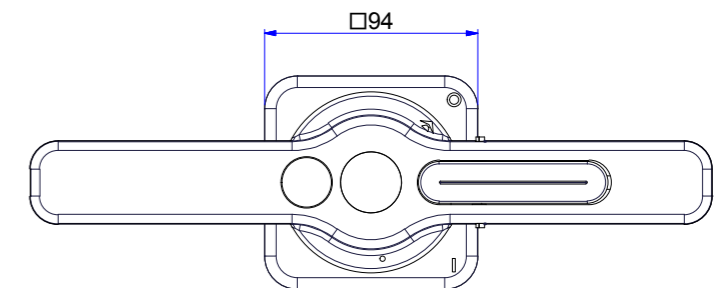
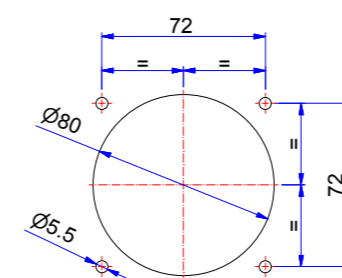

**GA6016**

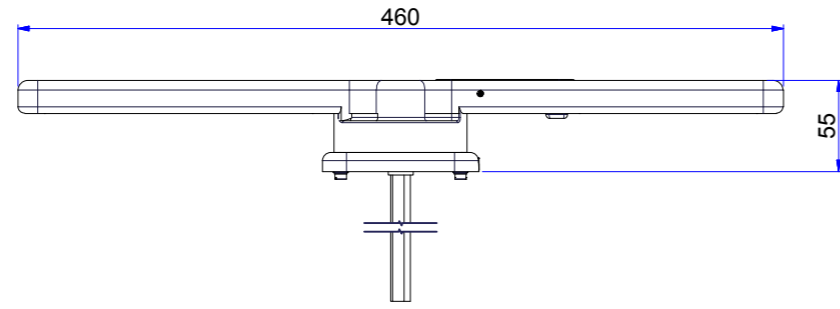

Foratura portella \_Door drilling

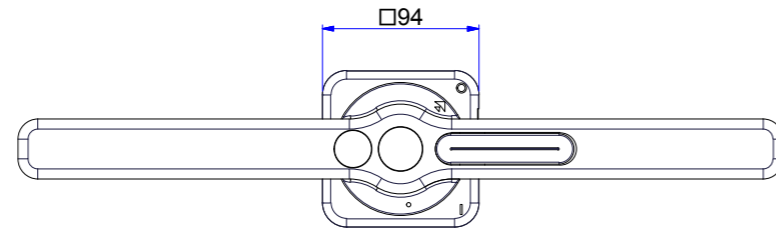
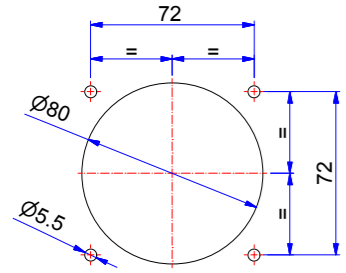

**MANIGLIA DOPPIA BLOCCO PORTA D'EMERGENZA**  
\_emergency door interlock double handle

Tipo_type	GT5	GT6
Codice_code	GA6003	GA6015

Albero di comando standard lunghezza 300 mm incluso in ogni confezione  
\_Standard shaft length 300 mm included into the package

**GA6003**

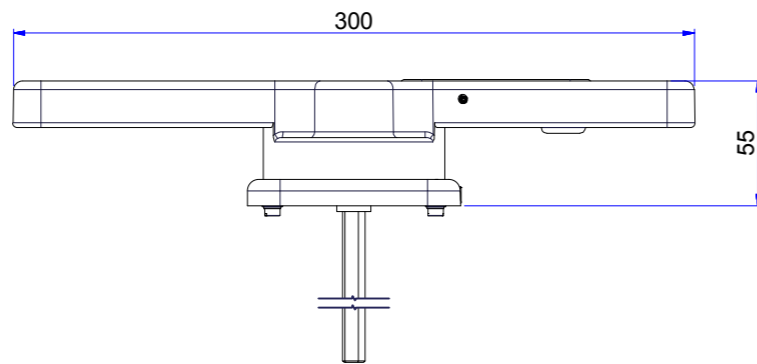
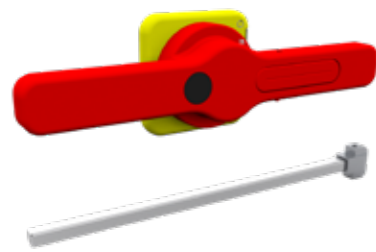

Foratura portella \_Door drilling

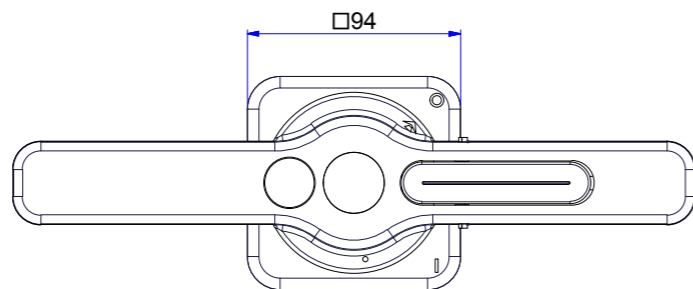
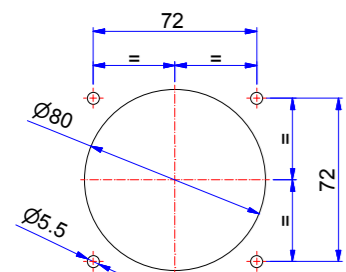

**GA6015**

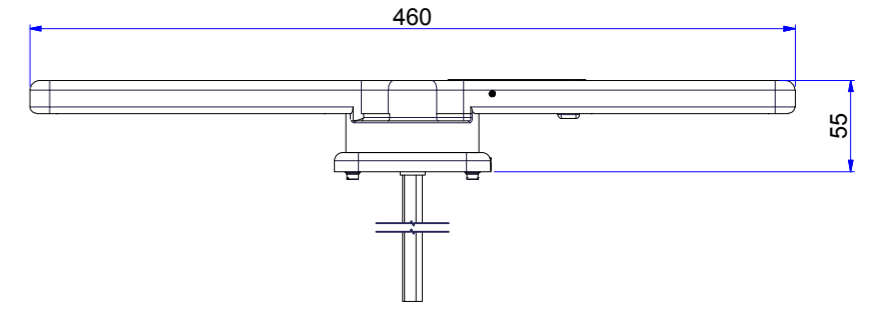

Foratura portella \_Door drilling

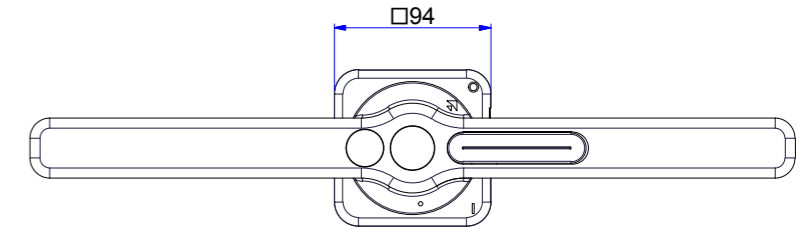
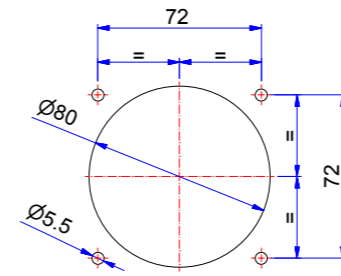

**MANIGLIA DIRETTA DOPPIA**  
\_ double direct handle

Tipo_type	GT5	GT6
Codice_code	GA6005	GA6006

Albero di comando disponibile in diverse lunghezze \_shaft available in different lengths

**GA6005**

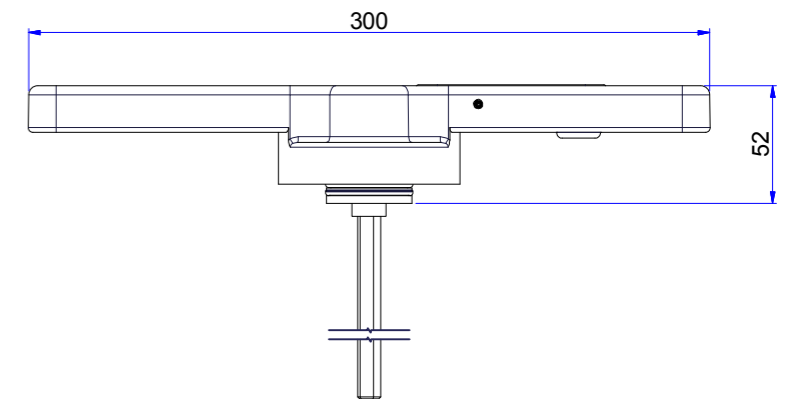

Foratura portella \_Door drilling

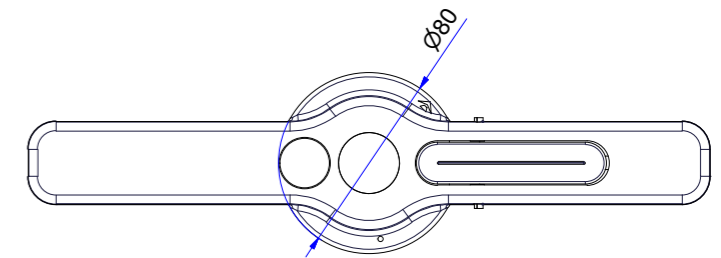
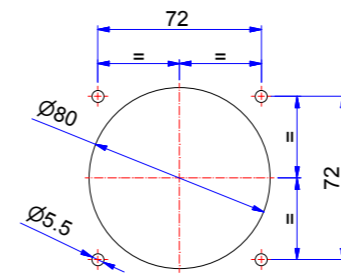



GA6006

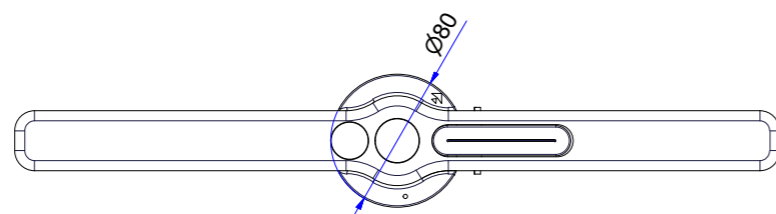
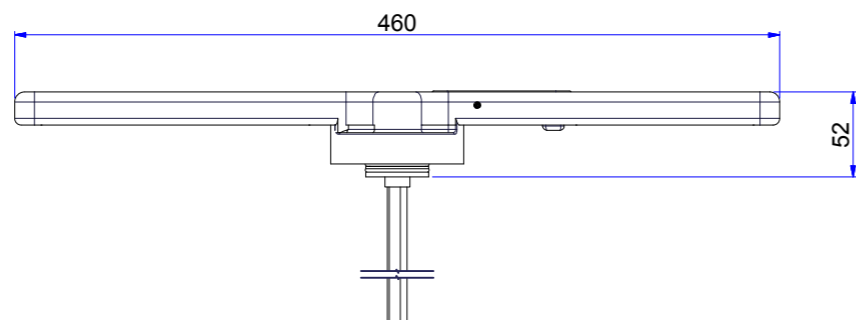

**MANIGLIA DOPPIA BLOCCO PORTA NERA 3150/4000 A**  
**\_black double door interlock handle 3150/4000A**

Tipo_type	GT5	GT6
Codice_code	-	GA6007

Albero di comando disponibile in diverse lunghezze \_shaft available in different lengths

GA6007

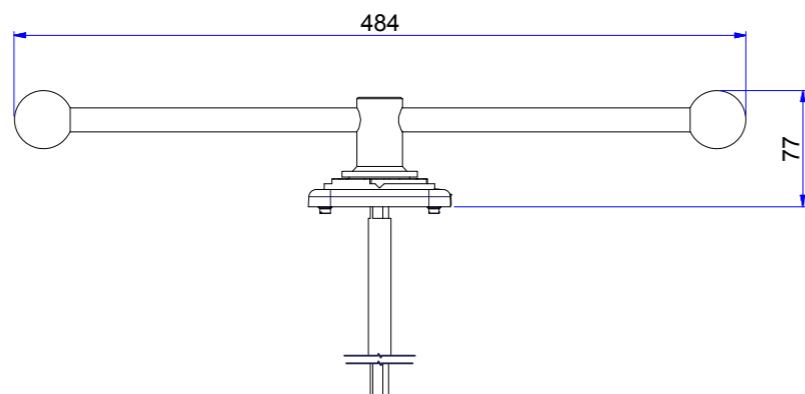
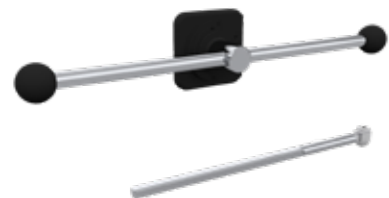

Foratura portella \_Door drilling

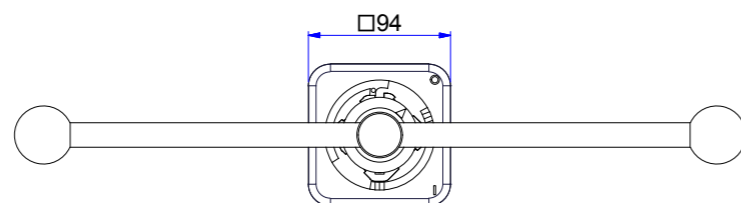
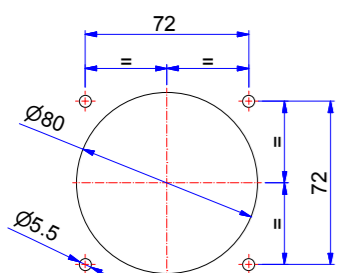

**MANIGLIA DOPPIA BLOCCO PORTA GIALLA 3150/4000A**  
**\_yellow door interlock double handle 3150/4000A**

Tipo_type	GT5	GT6
Codice_code	-	GA6008

Albero di comando disponibile in diverse lunghezze \_shaft available in different lengths

GA6008

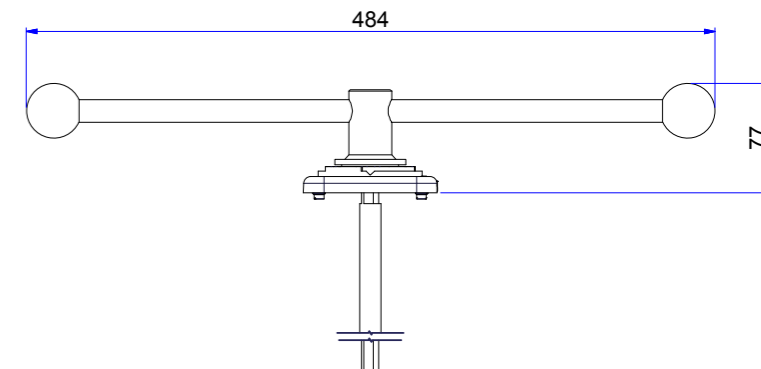
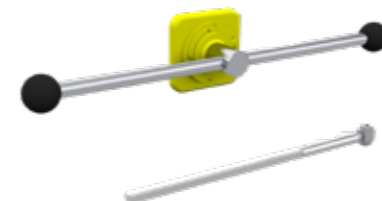

Foratura portella \_Door drilling

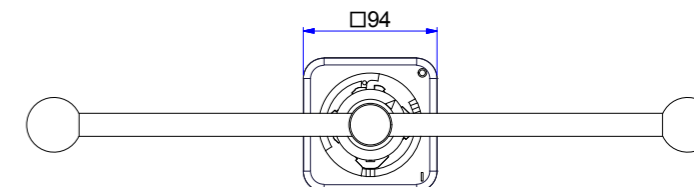
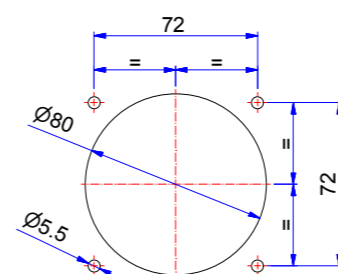

**MANIGLIA DIRETTA DOPPIA 3150/4000A**  
**\_double direct handle 3150/4000A**

Tipo_type	GT5	GT6
Codice_code	-	GA6009

Albero di comando disponibile in diverse lunghezze \_shaft available in different lengths

GA6009

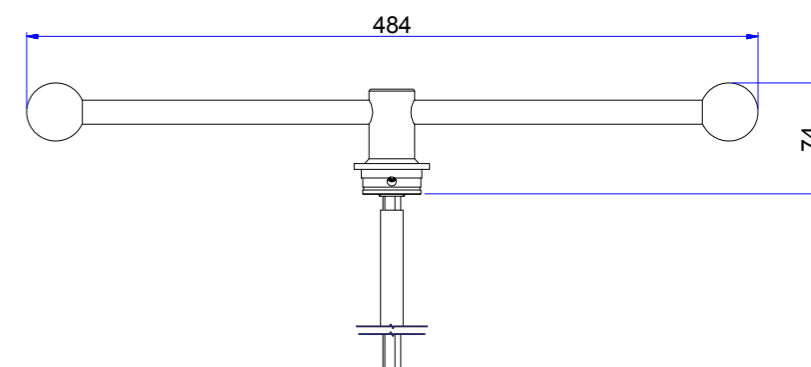
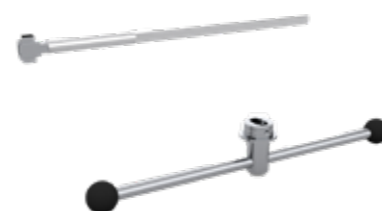

Foratura portella \_Door drilling

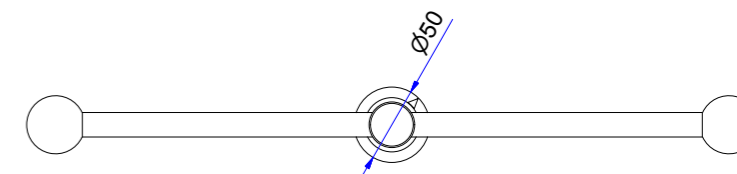
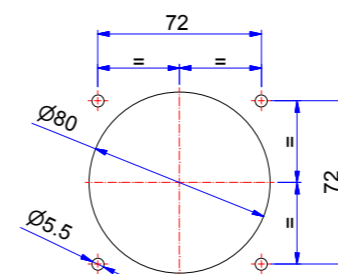

# COMMUTATORI MANUALI E BY-PASS

\_MANUAL CHANGE-OVER  
SWITCHES

**CMA 32 ÷ 4000 A**



## GENERALITÀ

Serie di commutatori ad azionamento manuale che permettono l'apertura e la commutazione di due circuiti elettrici in bassa tensione. Sono realizzati interbloccando due normali interruttori sezionatori della serie VISUALCOMPACT. La posizione sovrapposta dei due interruttori sezionatori rende particolarmente compatta questa soluzione facilitando notevolmente il collegamento a cavi o barre.

## CARATTERISTICHE GENERALI

3 posizioni I-O-II  
 versione senza zero con sovrapposizione dei contatti I, I+II, II (overlapping) fino a 3150A.  
 Interruttori-sezionatori interbloccati in sovrapposizione o orizzontalmente  
 Visibilità diretta, mediante finestrelle, dei contatti fissi e mobili  
 Manovre a scatto rapido indipendente  
 Doppia interruzione per ogni polo  
 Alto potere di interruzione (AC-23A IEC 60947-3)  
 Elevata durata meccanica ed elettrica  
 Adatti per utilizzo in climi tropicali  
 Ampia gamma di accessori  
 Comando di tipo rotativo frontale a mezzo di:  
 Maniglia esterna a doppio isolamento con dispositivo bloccoporta nelle posizioni I e II  
 Grado di protezione IP65.  
 Lucchettabile fino a 3 lucchetti in posizione O  
 Possibilità di esecuzione per by-pass fino a 1250A 35kA  
 Possibilità di esecuzioni speciali di commutatori a 6-8 poli

## CONDIZIONI NORMALI DI SERVIZIO, MONTAGGIO E TRASPORTO

temperatura ambiente di immagazzinamento e trasporto - 25°C + 55°C  
 temperatura ambiente di funzionamento - 20°C + 40°C  
 in caso di temperatura ambiente ( $t_a$ ) superiore, applicare la seguente formula di declassamento:

$$I_{The} = k I_{Th} \text{ dove } K = 1 - \frac{t_a - 40}{100}$$

umidità relativa max 95%  
 frequenza nominale 50 - 60 Hz  
 altitudine max 2000 m s.l.m.  
 grado di inquinamento 3 secondo IEC 60947-1  
 tipo di servizio (secondo IEC 60947-1):  
 servizio 8 ore  
 servizio ininterrotto  
 servizio intermittente 60% classe 30  
 servizio temporaneo  
 servizio periodico

**Per condizioni di impiego diverse consultare il costruttore.**

## CONFORMITÀ ALLE NORME

IEC 60947-1|IEC 60947-3|UNI EN 60947-1|UNI EN 60947-3

## CERTIFICATI E OMOLOGAZIONI

KEMA | RINA | ENEL codice 13.32.23 | A2A | CESI | IENGF | EAC

## GENERALITIES

Manually Operated Changeover Switches, suitable for breaking and switching between two low voltage electrical circuits. They are made by two standard switches of VISUALCOMPACT series, mechanically interlocked. The arrangement of two switches mounted one on top of the other makes this execution particularly compact and easy to connect to cables or bus-bars.

## GENERAL CHARACTERISTICS

3 positions I-O-II  
 Version without 0 (overlapping) functions I, I+II, II up to 3150A  
 Load break switches two-layer or horizontally interlocked  
 Visibility of fixed and moving contacts by means of windows  
 Independent fast action operation  
 Double break contacts  
 High breaking capacity (ac-23a iec 60947-3)  
 High electrical and mechanical endurance  
 Resistant to damp heat  
 Wide range of accessories  
 Rotary front operation by means of:  
 External double insulated handle with door-interlock in I and II position.  
 IP65 degree of protection.  
 Padlockable with up to three padlocks in O position  
 ByPass version available up to 1250 A, 35kA.  
 6-8 pole special execution available.

## NORMAL SERVICE, MOUNTING AND TRANSPORT CONDITIONS

storage and transport ambient temperature - 25°C + 55°C  
 working ambient temperature - 20°C + 40°C  
 in case of higher ambient temperature ( $t_a$ ) consider the following derating formula:

$$I_{The} = k I_{Th} \text{ dove } K = 1 - \frac{t_a - 40}{100}$$

relative humidity max 95%  
 rated frequency 50 - 60 Hz  
 altitude max 2000 m a.s.l.  
 pollution degree 3 according IEC 60947-1  
 duty (IEC 60947-1):  
 eight-hour duty  
 uninterrupted duty  
 intermittent duty 60% class 30  
 temporary duty  
 periodic duty

**For different operating conditions please contact the manufacturer.**

## CONFORMITY TO STANDARDS

IEC 60947-1|IEC 60947-3|UNI EN 60947-1|UNI EN 60947-3

## CERTIFICATES AND APPROVALS

KEMA | RINA | ENEL code 13.32.23 | A2A | CESI | IENGF | EAC



Tipo _type	Corrente nominale _rated current	Senza maniglia _without handle		Maniglia blocco porta _door interlock handle		
		POLI _POLES	CODICE _CODES	POLI _POLES	CODICE _CODES	
CS1P	32 A	3P	11008SM	3P	110008	
		4P	11018SM	4P	110108	
	45A	3	110018SM	3	110018	
		4	110118SM	4	110118	
	63A	3	110028SM	3	110028	
		4	110128SM	4	110128	
	80A	3	110038SM	3	110038	
		4	110138SM	4	110138	
	100A	3	110048SM	3	110048	
		4	110148SM	4	110148	
	125A	3	110058SM	3	110058	
		4	110158SM	4	110158	
160A	3	110068SM	3	110068		
	4	110168SM	4	110168		
CS2P	160A	3	120018SM	3	120018	
		4	120118SM	4	120118	
	200A	3	120028SM	3	120028	
		4	120128SM	4	120128	
	250A	3	120038SM	3	120038	
		4	120138SM	4	120138	
	315A	3	120048SM	3	120048	
		4	120148SM	4	120148	
	315A	3	130018SM	3	130018	
		4	130118SM	4	130118	
	400A	3	130028SM	3	130028	
		4	130128SM	4	130128	
500A	3	130038SM	3	130038		
	4	130138SM	4	130138		
CS3P	630A	3	140038SM	3	140038	
		4	140138SM	4	140138	
	800A	3	140048SM	3	140048	
		4	140148SM	4	140148	
	800A	3	150008SM	3	150008	
		4	150108SM	4	150108	
	1000A	3	150018SM	3	150018	
		4	150118SM	4	150118	
	1250A	3	150028SM	3	150028	
		4	150128SM	4	150128	
	CS4P	800A	3	150078SM	3	150078
			4	150178SM	4	150178
1000A		3	150088SM	3	150088	
		4	150188SM	4	150188	
1250A		3	150098SM	3	150098	
		4	150198SM	4	150198	
1600A		3	150038SM	3	150038	
		4	150138SM	4	150138	
2000A		3	150048SM	3	150048	
		4	150148SM	4	150148	
2500A		3	150058SM	3	150058	
		4	150158SM	4	150158	
3150A	3	150068SM	3	150068		
	4	150168SM	4	150168		
CS5P (35kA)	1600A	3	160008SM	3	160008	
		4	160108SM	4	160108	
	2000A	3	160018SM	3	160018	
		4	160118SM	4	160118	
	2500A	3	160028SM	3	160028	
		4	160128SM	4	160128	
	3150A	3	160038SM	3	160038	
		4	160138SM	4	160138	
	CS5P (50kA)	800A	3	150078SM	3	150078
			4	150178SM	4	150178
		1000A	3	150088SM	3	150088
			4	150188SM	4	150188
1250A		3	150098SM	3	150098	
		4	150198SM	4	150198	
1600A		3	150038SM	3	150038	
		4	150138SM	4	150138	
2000A		3	150048SM	3	150048	
		4	150148SM	4	150148	
2500A		3	150058SM	3	150058	
		4	150158SM	4	150158	
3150A	3	150068SM	3	150068		
	4	150168SM	4	150168		
CS6P	1600A	3	160008SM	3	160008	
		4	160108SM	4	160108	
	2000A	3	160018SM	3	160018	
		4	160118SM	4	160118	
	2500A	3	160028SM	3	160028	
		4	160128SM	4	160128	
	3150A	3	160038SM	3	160038	
		4	160138SM	4	160138	

# COP

Commutatori orizzontali  
\_horizontal change-over  
switches



Tipo _type	Corrente nominale _rated current	Senza maniglia _without handle		Maniglia blocco porta _door interlock handle		
		POLI _POLES	CODICE _CODES	POLI _POLES	CODICE _CODES	
<b>CO1P</b>	32 A	3	11003SM	3	110003	
		4	110103SM	4	110103	
	45A	3	110013SM	3	110013	
		4	110113SM	4	110113	
	63A	3	110023SM	3	110023	
		4	110123SM	4	110123	
	80A	3	110033SM	3	110033	
		4	110133SM	4	110133	
	100A	3	110043SM	3	110043	
		4	110143SM	4	110143	
	125A	3	110053SM	3	110053	
		4	110153SM	4	110153	
	160A	3	110063SM	3	110063	
		4	110163SM	4	110163	
	<b>CO2P</b>	160A	3	120013SM	3	120013
			4	120113SM	4	120113
200A		3	120023SM	3	120023	
		4	120123SM	4	120123	
250A		3	120033SM	3	120033	
		4	120133SM	4	120133	
315A	3	120043SM	3	120043		
	4	120143SM	4	120143		
<b>CO3P</b>	315A	3	130013SM	3	130013	
		4	130113SM	4	130113	
	400A	3	130023SM	3	130023	
		4	130123SM	4	130123	
	500A	3	130033SM	3	130033	
		4	130133SM	4	130133	
<b>CO4P</b>	630A	3	140033SM	3	140033	
		4	140133SM	4	140133	
	800A	3	140043SM	3	140043	
		4	140143SM	4	140143	
	800A	3	150003SM	3	150003	
		4	150103SM	4	150103	
<b>CO5P (35kA)</b>	1000A	3	150013SM	3	150013	
		4	150113SM	4	150113	
	1250A	3	150023SM	3	150023	
		4	150123SM	4	150123	
	800A	3	150073SM	3	150073	
		4	150173SM	4	150173	
<b>CO5P (50kA)</b>	1000A	3	150083SM	3	150083	
		4	150183SM	4	150183	
	1250A	3	150093SM	3	150093	
		4	150193SM	4	150193	
	1600A	3	150033SM	3	150033	
		4	150133SM	4	150133	
2000A	3	150043SM	3	150043		
	4	150143SM	4	150143		
<b>CO6P</b>	2500A	3	150053SM	3	150053	
		4	150153SM	4	150153	
	3150A	3	150063SM	3	150063	
		4	150163SM	4	150163	
	1600A	3	160003SM	3	160003	
		4	160103SM	4	160103	
2000A	3	160013SM	3	160013		
	4	160113SM	4	160113		
2500A	3	160023SM	3	160023		
	4	160123SM	4	160123		
3150A	3	160033SM	3	160033		
	4	160133SM	4	160133		

# BYP

BYP sovrapposti | Commutatori BY-PASS

## GENERALITÀ

I commutatori by-pass sono una combinazione di tre interruttori interbloccati tra loro meccanicamente così da costituire un dispositivo in grado di collegare in derivazione parti in manutenzione.



I codici riportati nelle tabelle corrispondono alla portata indicata. Il codice, di un by-pass con valori di portata (Amp.) diverso da quelli riportati nelle tabelle, si ottiene aggiungendo la desinenza 0 al codice del corrispondente sezionatore.

\_By-pass switch disconnectors codes written in the tables corresponding at the specific rated current value. To order a by-pass switch disconnector, not included in these tables, add 0 at the end of the code of the corresponding switch disconnector.

\_BYP two layers | BY-PASS change-over switches

## GENERALITIES

By Pass CHangeover switches are a combination of three mechanically interlocked switches, make to shunt circuit sections that has to go under maintenance.

Tipo _type	Corrente nominale _rated current	Senza maniglia _without handle		Maniglia blocco porta _door interlock handle	
		POLI _POLES	CODICE _CODES	POLI _POLES	CODICE _CODES
<b>BYP1 SOVRAPPOSTI _TWO LAYERS</b>	125A	3	110050SM	3	110050
		4	110150SM	4	110150
<b>BYP2 SOVRAPPOSTI _TWO LAYERS</b>	250A	3	120030SM	3	120030
		4	120130SM	4	120130
<b>BYP3 SOVRAPPOSTI _TWO LAYERS</b>	400A	3	130020SM	3	130020
		4	130120SM	4	130120
<b>BYP4 SOVRAPPOSTI _TWO LAYERS</b>	800A	3	140040SM	3	140040
		4	140140SM	4	140140
<b>BYP5 SOVRAPPOSTI _TWO LAYERS</b>	1250A	3	150020SM	3	150020
		4	150120SM	4	150120



**SERIE\_SERIES CMA**

Caratteristiche tecniche _Technical Features	Tipo _Type		CS CO - 1P							CS CO - 2P			
	Corrente nominale _Rated current	In	A	32	45	63	80	100	125	160	160	200	250
Tensione nominale d'isolamento _Rated insulation voltage	Ui	V	1500	1500	1500	1500	1500	1500	1500	1500	1500	1500	1500
Tensione nominale impulso _Shock resistance	U imp	kV	8	8	8	8	8	8	8	12	12	12	12
Corrente nominale termica _Thermal current	Ith	A	32	45	63	80	100	125	160	160	200	250	315
Corrente nominale d' impiego _Rated operational current													
AC-21A/B	400V	A	32	45	63	80	100	125	125/160	160	200	250	250/315
	500V	A	32	45	63	80	100	125	125/160	160	200	250	250/315
	690V	A	32	45	63	80	100	125	125/160	160	200	250	250/315
AC-22A/B	400V	A	32	45	63	80	100	125	125/160	160	200	250	250/315
	500V	A	32	45	63	80	100	125	125/125	160	200	250	250/250
	690V	A	32	45	63	80	100	125	125/125	160	200	250	250/250
AC-23A/B	400V	A	32	45	63	80	100	125	125/125	160	200	250	250/250
	500V	A	25	35	45	63	80	100	100/100	125	160	200	200/200
	690V	A	20	30	35	45	63	80	80/80	100	125	160	160/160
DC-21A/B	220V	A	32	45	63	80	100	125	125/160	160	200	250	250/315
	420V	A	-	-	-	-	-	-	-	160	200	250	250/315
	560V	A	-	-	-	-	-	-	-	-	-	-	-
DC-22A/B	220V	A	32	45	63	80	100	125	125/125	160	200	250	250/315
	420V	A	-	-	-	-	-	-	-	160	200	250	250/250
	560V	A	-	-	-	-	-	-	-	-	-	-	-
DC-23A/B	220V	A	20	30	35	45	63	80	80/80	160	200	250	250/250
	420V	A	-	-	-	-	-	-	-	160	200	250	250/250
	560V	A	-	-	-	-	-	-	-	-	-	-	-
Potere di chiusura _Rated making capacity	400V AC23	A	320	450	630	800	1000	1250	1250	1600	2000	2500	2500
Potere di interruzione _Breaking capacity	400V AC23	A	256	360	504	640	800	1000	1000	1280	1600	2000	2000
Corrente di breve durata _Short-circuit withstand current	1 sec	kA	5	5	5	5	5	5	5	8	8	8	8
Corrente di breve durata _Short-circuit withstand current	0,25 sec	kA	10	10	10	10	10	10	10	16	16	16	16
Potere di chiusura in corto circuito _Short-circuit making capacity	400V	kA	7,5	7,5	7,5	7,5	7,5	7,5	7,5	13,5	13,5	13,5	13,5
Potenza nominale d'impiego _Rated operational power	400V AC23	kW	17	23	33	42	52	65	65	85	105	130	130
Corrente di corto circuito condizionata da fusibile _Rated fuse short-circuit current													
Tipo fusibile _Backup fuse		A	32	45	63	80	100	125	160	160	200	250	315
Valore efficace _R.M.S. value		kA	50	50	50	50	50	50	50	50	50	50	50
Valore di picco _Peak value		kA	6	9	10	12	12	15	16	16	20	25	27
Durata meccanica _Mechanical endurance		n.	12000	12000	12000	12000	12000	10000	10000	10000	10000	10000	10000
Durata elettrica _Electrical endurance		n.	3000	3000	3000	3000	3000	2000	2000	2000	2000	2000	2000/200
Potenza condensatori a 400V _Rated capacitor power at 400V		kVAR	15	20	30	40	45	50	50	70	90	110	110
Potenza dissipata per polo _Power losses for pole		W	0,1	0,2	0,4	0,7	1,1	1,7	2,7	1,6	2,4	3,8	6,1
Dimensione cavo _Cable section		mmq	10	10	16	25	35	50	70	70	95	120	185
Dimensione barre _Bars dimension		MM	10x2	10x2	12x3	12x3	14x3	16x3	16x4	20x4	20x5	20x6	22x8
Peso netto _Net weight	3P	Kg	3,2 / 2	3,2 / 2	3,2 / 2	3,2 / 2	3,2 / 2	3,2 / 2	3,2 / 2	4,5 / 3	4,5 / 3	4,5 / 3	4,5 / 3
	4P		3,5 / 2,1	3,5 / 2,1	3,5 / 2,1	3,5 / 2,1	3,5 / 2,1	3,5 / 2,1	3,5 / 2,1	3,5 / 2,1	5 / 3,2	5 / 3,2	5 / 3,2

Caratteristiche tecniche _Technical Features	Tipo _Type		CS CO - 3P			CS CO - 4P		CS CO - 5P		
	Corrente nominale _Rated current	In	A	315	400	500	630	800	800	1000
Tensione nominale d'isolamento _Rated insulation voltage	Ui	V	1500	1500	1500	1500	1500	1500	1500	1500
Tensione nominale impulso _Shock resistance	U imp	kV	12	12	12	12	12	12	12	12
Corrente nominale termica _Thermal current	Ith	A	315	400	500	630	800	800	1000	1250
Corrente nominale d' impiego _Rated operational current										
AC-21A/B	400V	A	315	400	500/500	630	630/800	800	1000	1250
	500V	A	315	400	500/500	630	630/800	800	1000	1250
	690V	A	315	400	400/500	630	630/800	800	1000	1250
AC-22A/B	400V	A	315	400	500/500	630	630/800	800	1000	1250
	500V	A	315	400	400/400	630	630/630	800	1000	1250
	690V	A	315	400	400/400	630	630/630	800	1000	1250
AC-23A/B	400V	A	315	400	500/500	630	630/630	800	1000	1250
	500V	A	250	315	315/315	500	500/500	800	800	800
	690V	A	200	250	250/250	400	400/400	400	400	400
DC-21A/B	220V	A	315	400	400/500	630	630/800	800	1000	1250
	420V	A	315	400	400/500	630	630/800	-	-	-
	560V	A	315	400	400/500	630	630/800	-	-	-
DC-22A/B	220V	A	315	400	400/500	630	630/800	800	1000	1250
	420V	A	315	400	400/400	630	630/630	-	-	-
	560V	A	315	400	400/400	630	630/630	-	-	-
DC-23A/B	220V	A	315	400	400/400	630	630/630	500	630	800
	420V	A	315	400	400/400	630	630/630	-	-	-
	560V	A	315	400	400/400	630	630/630	-	-	-
Potere di chiusura _Rated making capacity	400V AC23	A	3150	4000	5000	6300	6300	8000	10000	12500
Potere di interruzione _Breaking capacity	400V AC23	A	2520	3200	4000	5040	5040	6400	8000	10000
Corrente di breve durata _Short-circuit withstand current	1 sec	kA	13	13	13	26,5	26,5	35	35	35
Corrente di breve durata _Short-circuit withstand current	0,25 sec	kA	26	26	26	53	53	70	70	70
Potere di chiusura in corto circuito _Short-circuit making capacity	400V	kA	26	26	26	30	30	73,5	73,5	73,5
Potenza nominale d'impiego _Rated operational power	400V AC23	kW	165	210	210	330	330	420	525	630
Corrente di corto circuito condizionata da fusibile _Rated fuse short-circuit current										
Tipo fusibile _Backup fuse		A	315	400	500	630	800	800	1000	1250
Valore efficace _R.M.S. value		kA	50	50	50	50	50	100	100	100
Valore di picco _Peak value		kA	27	30	37	40	40	50	60	70
Durata meccanica _Mechanical endurance		n.	8000	8000	8000	8000	8000	7000	7000	7000
Durata elettrica _Electrical endurance		n.	1500	1500	1500/200	1500	1500/200	1000	1000	1000
Potenza condensatori a 400V _Rated capacitor power at 400V		kVAR	140	180	180	300	300	380	475	600
Potenza dissipata per polo _Power losses for pole		W	5,9	9,4	14,8	15,6	25,7	17,5	27,3	42,7
Dimensione cavo _Cable section		mmq	185	2x120	2x150	2x185	2x240	2x240	-	-
Dimensione barre _Bars dimension		MM	30x6	2x25x5	2x30x5	2x40x5	2x40x6	2x50x5	2x50x5	2x50x5
Peso netto _Net weight	3P	Kg	9,4 / 7,5	9,4 / 7,5	9,4 / 7,5	15 / 13,8	15 / 13,8	28 / 23,5	36,7 / 31	46,6 / 40,3
	4P		10,2 / 8,3	10,2 / 8,3	10,2 / 8,3	16,8 / 14,6	16,8 / 14,6	30 / 25,2	39,2 / 33,5	50,8 / 44,2

**SERIE\_SERIES CMA**

Caratteristiche tecniche _Technical Features	Tipo _Type		CS CO  - 5P 50kA							CS CO - 6P			
	In	A	800	1000	1250	1600	2000	2500	3150	1600	2000	2500	3150
Corrente nominale _Rated current	In	A	800	1000	1250	1600	2000	2500	3150	1600	2000	2500	3150
Tensione nominale d'isolamento _Rated insulation voltage	Ui	V	1500	1500	1500	1500	1500	1500	1500	1500	1500	1500	1500
Tensione nominale impulso _Shock resistance	U imp	kV	12	12	12	12	12	12	12	12	8	8	8
Corrente nominale termica _Thermal current	Ith	A	800	1000	1250	1600	2000	2500	3150	1600	2000	2500	3150
Corrente nominale d' impiego _Rated operational current													
AC-21A/B	400V	A	800	1000	1250	1600	2000	2500	3150	1600	2000	2500	3150
	500V	A	800	1000	1250	1250	1600	2000	2500	1600	2000	2500	3150
	690V	A	800	1000	1250	1250	1250	1250	1250	1250	1250	1250	1250
AC-22A/B	400V	A	800	1000	1250	1250	1250	-	-	1600	2000	2500	1600
	500V	A	800	1000	1250	-	-	-	-	1250	1250	1250	-
	690V	A	800	1000	1250	-	-	-	-	400	400	800	-
AC-23A/B	400V	A	800	1000	1250	-	-	-	-	1250	1250	-	-
	500V	A	630	800	1000	-	-	-	-	800	800	-	-
	690V	A	500	630	800	-	-	-	-	400	400	-	-
DC-21A	220V	A	800	1000	1250	1600	2000	-	-	1600	2000	-	-
	420V	A	-	-	-	-	-	-	-	-	-	-	-
	560V	A	-	-	-	-	-	-	-	-	-	-	-
DC-22A	220V	A	800	1000	1250	-	-	-	-	-	-	-	-
	420V	A	-	-	-	-	-	-	-	-	-	-	-
	560V	A	-	-	-	-	-	-	-	-	-	-	-
DC-23A	220V	A	500	630	800	-	-	-	-	-	-	-	-
	420V	A	-	-	-	-	-	-	-	-	-	-	-
	560V	A	-	-	-	-	-	-	-	-	-	-	-
Potere di chiusura _Rated making capacity	400V AC23	A	8000	10000	12500	-	-	-	-	12500	12500	-	-
Potere di interruzione _Breaking capacity	400V AC23	A	6400	8000	10000	-	-	-	-	10000	10000	-	-
Corrente di breve durata _Short-circuit withstand current	1 sec	kA	50	50	50	50	50	50	50	60	60	70	70
Corrente di breve durata _Short-circuit withstand current	0,25 sec	kA	100	100	100	100	100	100	100	120	120	140	140
Potere di chiusura in corto circuito _Short-circuit making capacity	400V	kA	105	105	105	105	105	105	105	105	105	105	105
Potenza nominale d'impiego _Rated operational power	400V AC23	kW	420	525	630	630	630	-	-	630	630	-	-
Corrente di corto circuito condizionata da fusibile _Rated fuse short-circuit current													
Tipo fusibile _Backup fuse		A	800	1000	1250	-	-	-	-	-	-	-	-
Valore efficace _R.M.S. value		kA	100	100	100	-	-	-	-	-	-	-	-
Valore di picco _Peak value		kA	50	60	70	-	-	-	-	-	-	-	-
Durata meccanica _Mechanical endurance		n.	4000	4000	4000	4000	4000	2000	2500	4000	2500	2500	2500
Durata elettrica _Electrical endurance		n.	1000	1000	1000	500	500	500	500	1000	500	500	500
Potenza condensatori a 400V _Rated capacitor power at 400V		kVAR	380	475	600	-	-	-	-	780	850	1.100	1250
Potenza dissipata per polo _Power losses for pole		W	15,6	24,3	38,0	38,3	61,3	91,7	145,5	47,8	74,7	85,4	118,1
Dimensione cavo _Cable section		mmq	2x240	-	-	-	-	-	-	-	-	-	-
Dimensione barre _Bars dimension		MM	2x50x5	2x50x6	2x50x8	3x50x8	3x50x12	4x50x12	6x50x12	2x80x10	2x80x10	3x80x10	32x100x10
Peso netto _Net weight	3P	Kg	28 / 23,5	28 / 23,5	28 / 23,5	36,7 / 31	36,7 / 31	46,6 / 40,3	46,6 / 40,3	47 / 41,3	49,7 / 44	70 / 63,8	89,5 / 81,8
	4P		30 / 25,2	30 / 25,2	30 / 25,2	39,2 / 33,5	39,2 / 33,5	50,8 / 44,2	50,8 / 44,2	50,3 / 44,5	53 / 47,3	72 / 65,8	95,5 / 88

Caratteristiche tecniche _Technical Features	Tipo _Type		BYP - 1P							BYP - 2P			
	In	A	32	45	63	80	100	125	160	160	200	250	315
Corrente nominale _Rated current	In	A	32	45	63	80	100	125	160	160	200	250	315
Tensione nominale d'isolamento _Rated insulation voltage	Ui	V	1500	1500	1500	1500	1500	1500	1500	1500	1500	1500	1500
Tensione nominale impulso _Shock resistance	U imp	kV	8	8	8	8	8	8	8	12	12	12	12
Corrente nominale termica _Thermal current	Ith	A	32	45	63	80	100	125	160	160	200	250	315
Corrente nominale d' impiego _Rated operational current													
AC-21A/B	400V	A	32	45	63	80	100	125	125/160	160	200	250	250/315
	500V	A	32	45	63	80	100	125	125/160	160	200	250	250/315
	690V	A	32	45	63	80	100	125	125/160	160	200	250	250/315
AC-22A/B	400V	A	32	45	63	80	100	125	125/160	160	200	250	250/315
	500V	A	32	45	63	80	100	125	125/125	160	200	250	250/250
	690V	A	32	45	63	80	100	125	125/125	160	200	250	250/250
AC-23A/B	400V	A	32	45	63	80	100	125	125/125	160	200	250	250/250
	500V	A	25	35	45	63	80	100	100/100	125	160	200	200/200
	690V	A	20	30	35	45	63	80	80/80	100	125	160	160/160
DC-21A	220V	A	32	45	63	80	100	125	125/160	160	200	250	250/315
	420V	A	-	-	-	-	-	-	-	160	200	250	250/315
	560V	A	-	-	-	-	-	-	-	-	-	-	-
DC-22A	220V	A	32	45	63	80	100	125	125/125	160	200	250	250/315
	420V	A	-	-	-	-	-	-	-	160	200	250	250/250
	560V	A	-	-	-	-	-	-	-	-	-	-	-
DC-23A	220V	A	20	30	35	45	63	80	80/80	160	200	250	250/250
	420V	A	-	-	-	-	-	-	-	160	200	250	250/250
	560V	A	-	-	-	-	-	-	-	-	-	-	-
Potere di chiusura _Rated making capacity	400V AC23	A	320	450	630	800	1000	1250	1250	1600	2000	2500	2500
Potere di interruzione _Breaking capacity	400V AC23	A	256	360	504	640	800	1000	1000	1280	1600	2000	2000
Corrente di breve durata _Short-circuit withstand current	1 sec	kA	5	5	5	5	5	5	5	8	8	8	8
Corrente di breve durata _Short-circuit withstand current	0,25 sec	kA	10	10	10	10	10	10	10	16	16	16	16
Potere di chiusura in corto circuito _Short-circuit making capacity	400V	kA	7,5	7,5	7,5	7,5	7,5	7,5	7,5	13,5	13,5	13,5	13,5
Potenza nominale d'impiego _Rated operational power	400V AC23	kW	17	23	33	42	52	65	65	85	105	130	130
Corrente di corto circuito condizionata da fusibile _Rated fuse short-circuit current													
Tipo fusibile _Backup fuse		A	32	45	63	80	100	125	160	160	200	250	315
Valore efficace _R.M.S. value		kA	50	50	50	50	50	50	50	50	50	50	50
Valore di picco _Peak value		kA	6	9	10	12	12	15	16	16	20	25	27
Durata meccanica _Mechanical endurance		n.	12000	12000	12000	12000	12000	10000	10000	10000	10000	10000	10000
Durata elettrica _Electrical endurance		n.	3000	3000	3000	3000	3000	2000	2000	2000	2000	2000	2000/200
Potenza condensatori a 400V _Rated capacitor power at 400V		kVAR	15	20	30	40	45	50	50	70	90	110	110
Potenza dissipata per polo _Power losses for pole		W	0,1	0,2	0,4	0,7	1,1	1,7	2,7	1,6	2,4	3,8	6,1
Dimensione cavo _Cable section		mmq	10	10	16	25	35	50	70	70	95	120	185
Dimensione barre _Bars dimension		MM	10x2	10x2	12x3	12x3	14x3	16x3	16x4	20x4	20x5	20x6	22x8
Peso netto _Net weight	3P	Kg	4	4	4	4	4	4	4	6	6	6	6
	4P		4,5	4,5	4,5	4,5	4,5	4,5	4,5	6,5	6,5	6,5	6,5

**SERIE\_SERIES CMA**

Caratteristiche tecniche _Technical Features	Tipo _Type		BYP - 3P			BYP - 4P		BYP - 5P		
	In	A	315	400	500	630	800	800	1000	1250
Corrente nominale _Rated current	In	A	315	400	500	630	800	800	1000	1250
Tensione nominale d'isolamento _Rated insulation voltage	Ui	V	1500	1500	1500	1500	1500	1500	1500	1500
Tensione nominale impulso _Shock resistance	U imp	kV	12	12	12	12	12	12	12	12
Corrente nominale termica _Thermal current	Ith	A	315	400	500	630	800	800	1000	1250
Corrente nominale d' impiego _Rated operational current										
AC-21A/B	400V	A	315	400	500/500	630	630/800	800	1000	1250
	500V	A	315	400	500/500	630	630/800	800	1000	1250
	690V	A	315	400	400/500	630	630/800	800	1000	1250
AC-22A/B	400V	A	315	400	500/500	630	630/800	800	1000	1250
	500V	A	315	400	400/400	630	630/630	800	1000	1250
	690V	A	315	400	400/400	630	630/630	800	1000	1250
AC-23A/B	400V	A	315	400	500/500	630	630/630	800	1000	1250
	500V	A	250	315	315/315	500	500/500	800	800	800
	690V	A	200	250	250/250	400	400/400	400	400	400
DC-21A	220V	A	315	400	400/500	630	630/800	800	1000	1250
	420V	A	315	400	400/500	630	630/800	-	-	-
	560V	A	315	400	400/500	630	630/800	-	-	-
DC-22A	220V	A	315	400	400/500	630	630/800	800	1000	1250
	420V	A	315	400	400/400	630	630/630	-	-	-
	560V	A	315	400	400/400	630	630/630	-	-	-
DC-23A	220V	A	315	400	400/400	630	630/630	500	630	800
	420V	A	315	400	400/400	630	630/630	-	-	-
	560V	A	315	400	400/400	630	630/630	-	-	-
Potere di chiusura _Rated making capacity	400V AC23	A	3150	4000	5000	6300	6300	8000	10000	12500
Potere di interruzione _Breaking capacity	400V AC23	A	2520	3200	4000	5040	5040	6400	8000	10000
Corrente di breve durata _Short-circuit withstand current	1 sec	kA	13	13	13	26,5	26,5	35	35	35
Corrente di breve durata _Short-circuit withstand current	0,25 sec	kA	26	26	26	53	53	70	70	70
Potere di chiusura in corto circuito _Short-circuit making capacity	400V	kA	26	26	26	30	30	73,5	73,5	73,5
Potenza nominale d'impiego _Rated operational power	400V AC23	kW	165	210	210	330	330	420	525	630
Corrente di corto circuito condizionata da fusibile _Rated fuse short-circuit current										
Tipo fusibile _Backup fuse		A	315	400	500	630	800	800	1000	1250
Valore efficace _R.M.S. value		kA	50	50	50	50	50	100	100	100
Valore di picco _Peak value		kA	27	30	37	40	40	50	60	70
Durata meccanica _Mechanical endurance		n.	8000	8000	8000	8000	8000	7000	7000	7000
Durata elettrica _Electrical endurance		n.	1500	1500	1500/200	1500	1500/200	1000	1000	1000
Potenza condensatori a 400V _Rated capacitor power at 400V		kVAR	140	180	180	300	300	380	475	600
Potenza dissipata per polo _Power losses for pole		W	5,9	9,4	14,8	15,6	25,7	17,5	27,3	42,7
Dimensione cavo _Cable section		mmq	185	2x120	2x150	2x185	2x240	2x240	-	-
Dimensione barre _Bars dimension		MM	30x6	2x25x5	2x30x5	2x40x5	2x40x6	2x50x5	2x50x5	2x50x5
Peso netto _Net weight	3P	Kg	12,5	12,5	12,5	21	21	38,6	38,6	38,6
	4P		14	14	14	23,5	23,5	41,7	41,7	41,7

**CS1P 32 - 160 A**

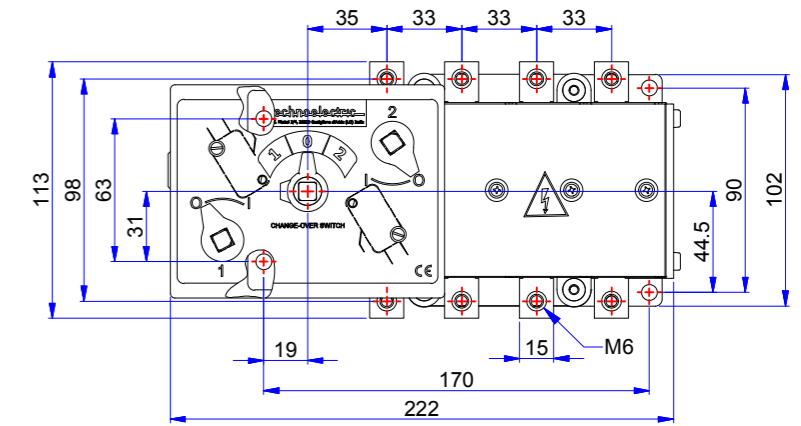

Foratura portella \_Door drilling

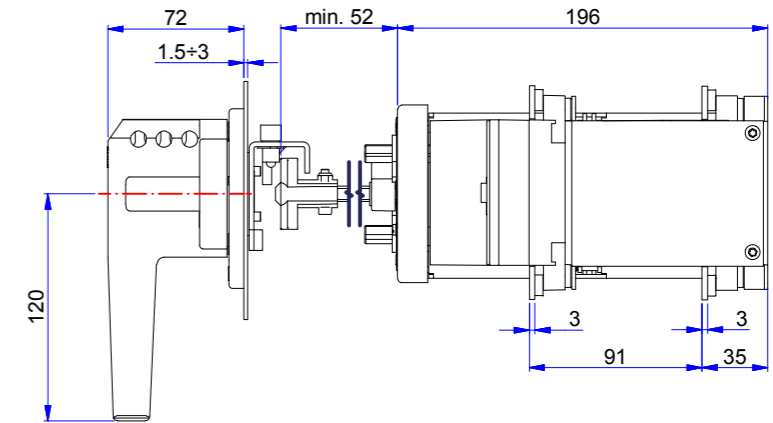
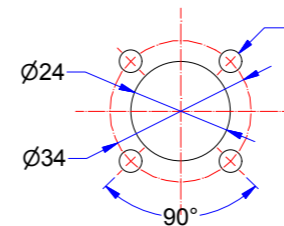

**CS2P 160 - 315 A**

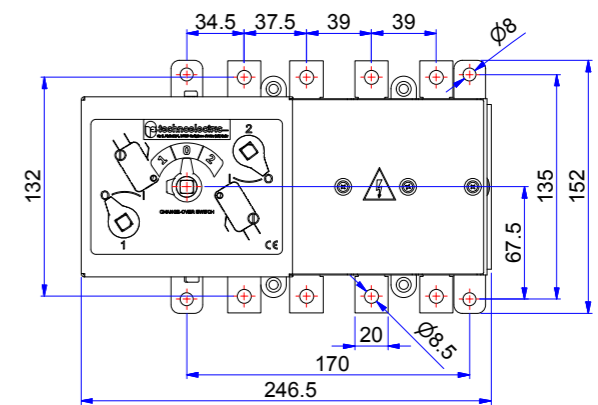

Foratura portella \_Door drilling

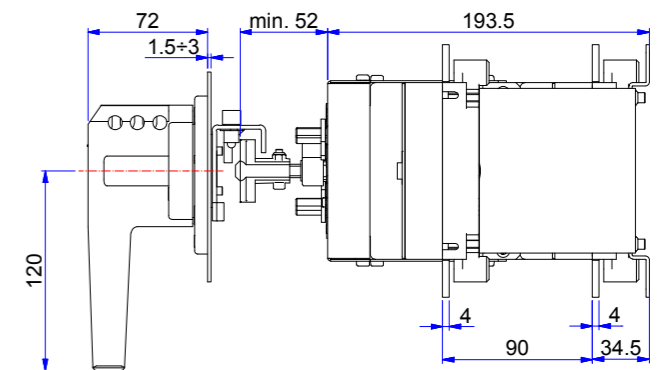
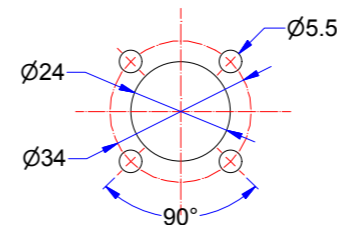

**CS3P 315 - 500 A**

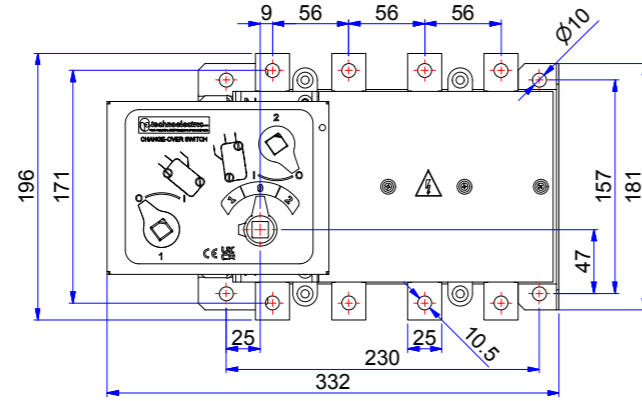

Foratura portella \_Door drilling

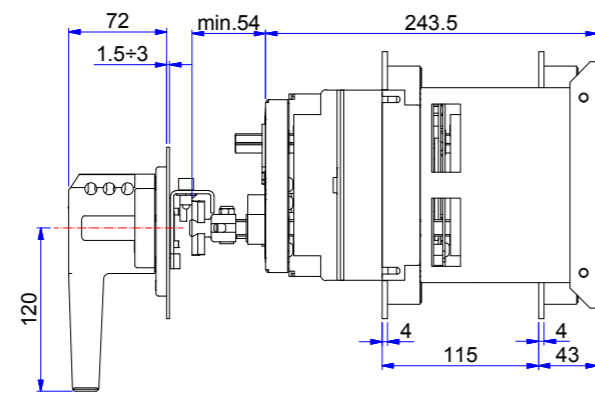
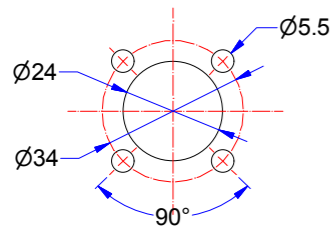

**CS5P 800 ÷ 1250 A**

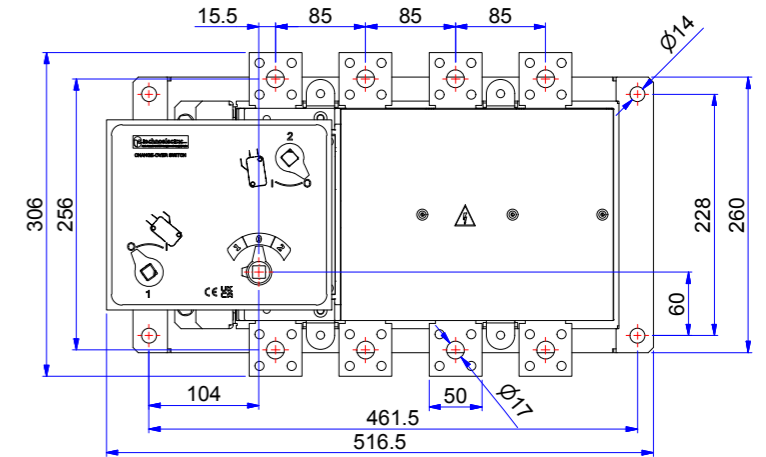

Foratura portella \_Door drilling

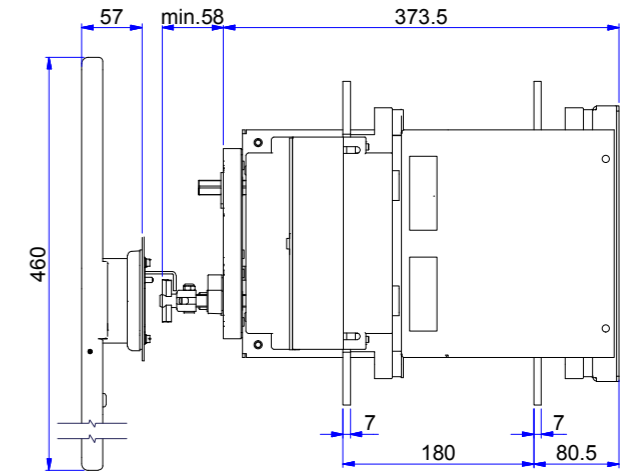
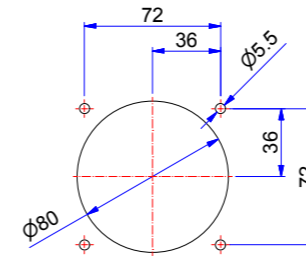

**CS4P 630 - 800 A**

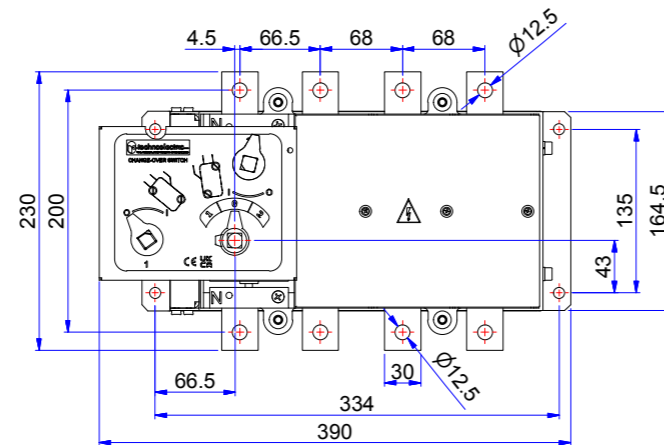

Foratura portella \_Door drilling

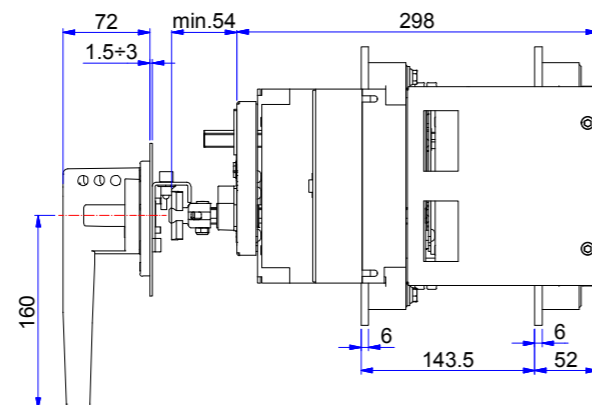
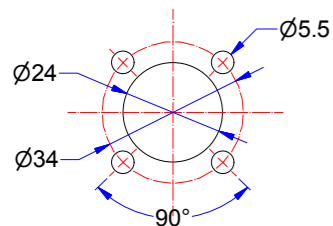

**CS5P 1600 ÷ 2000 A**

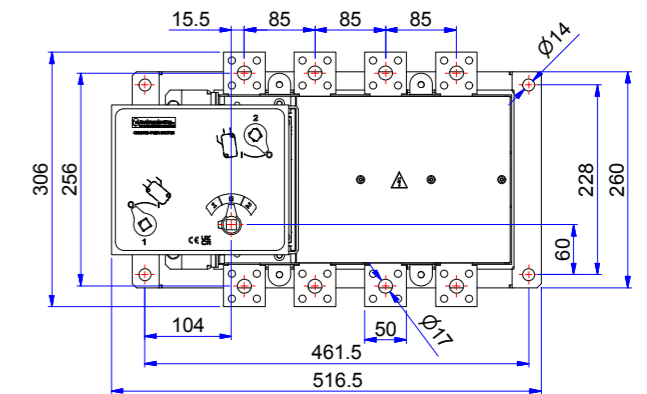

Foratura portella \_Door drilling

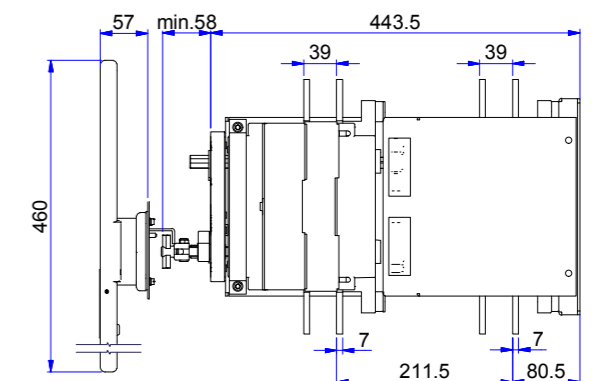
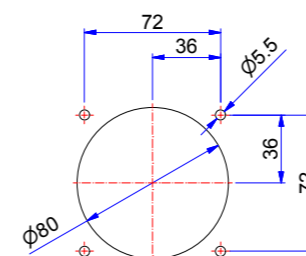



**CS5P 2500 ÷ 3150 A**

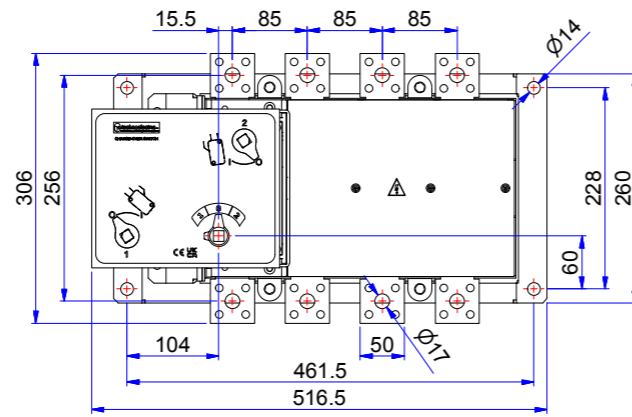

Foratura portella \_Door drilling

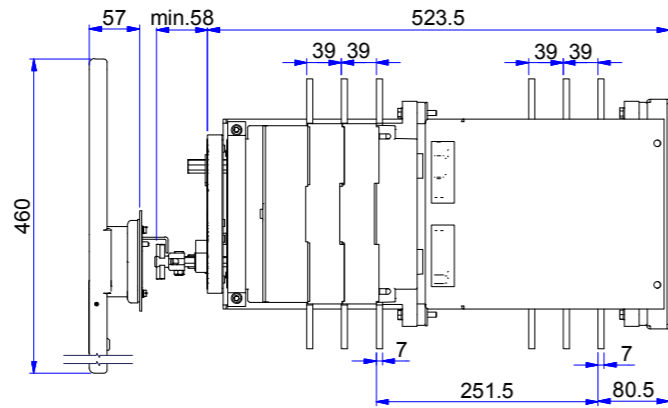
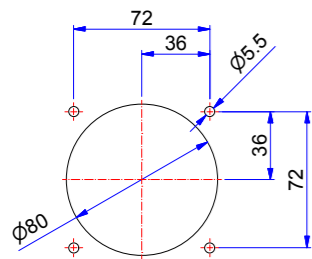

**CS6P 1600 A (neutro \_neutral 1250 A)**

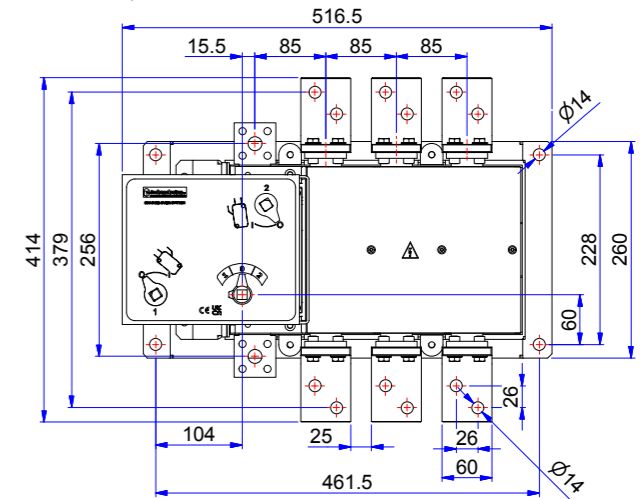

Foratura portella \_Door drilling

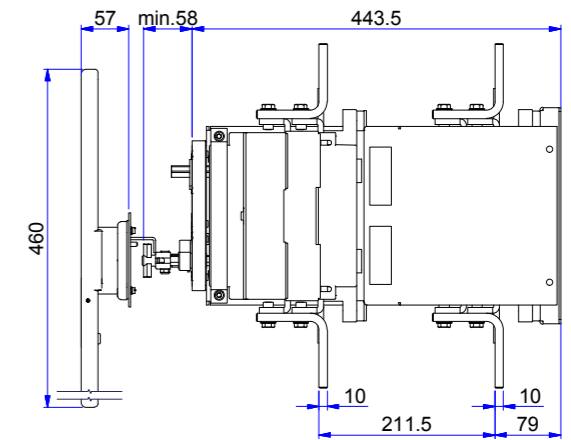
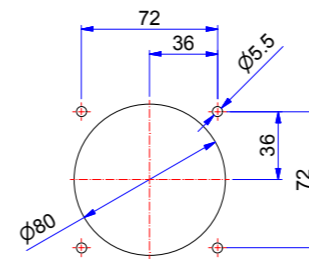

**CS6P FN 1600 A**

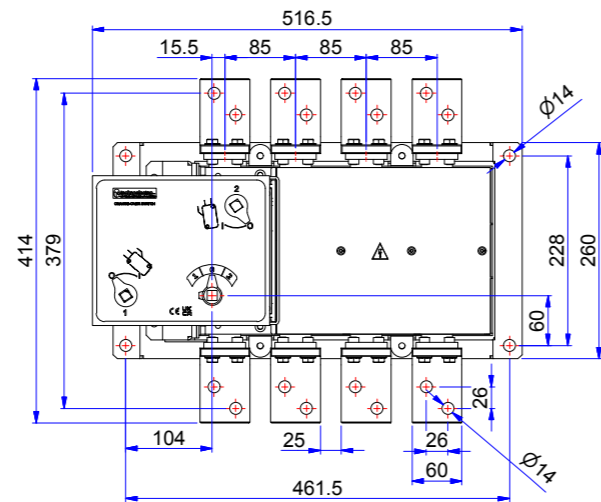

Foratura portella \_Door drilling

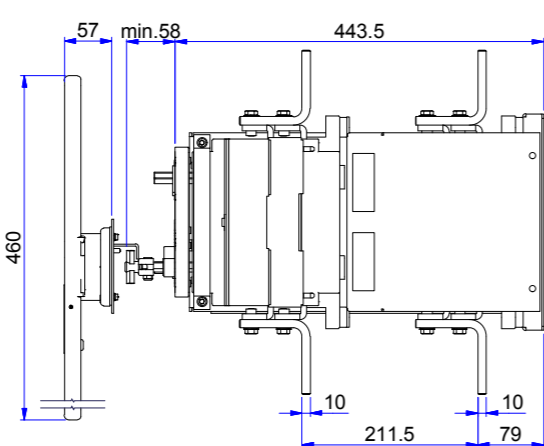
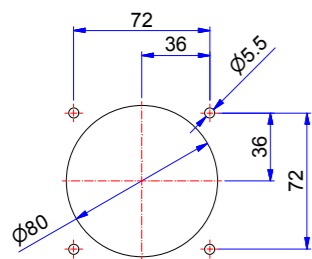

**CS6P FN 2000 A**

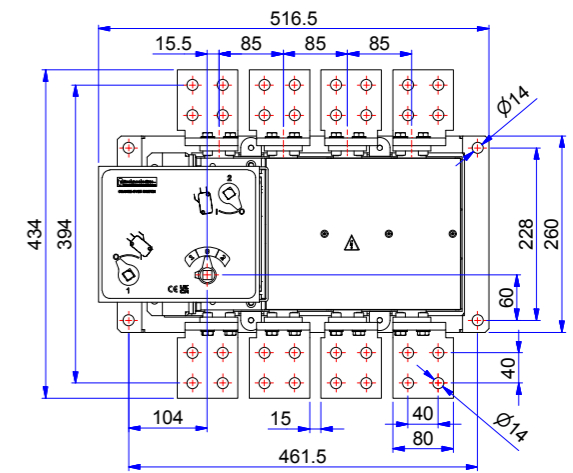

Foratura portella \_Door drilling

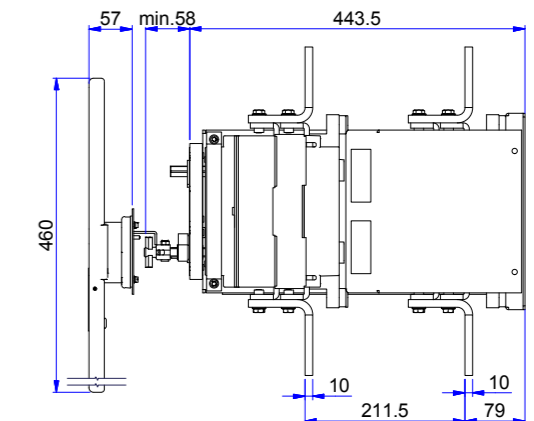
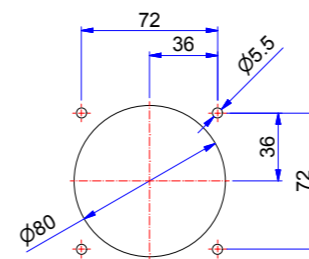

**CS6P 2000 A (neutro \_neutral 1250 A)**

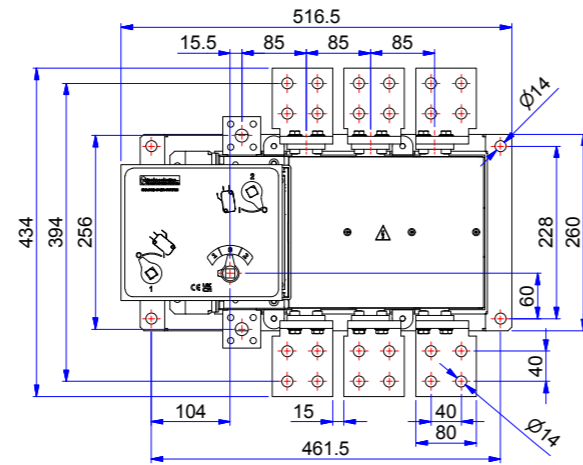

Foratura portella \_Door drilling

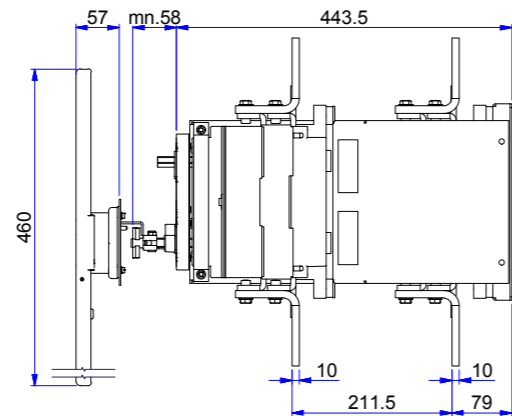
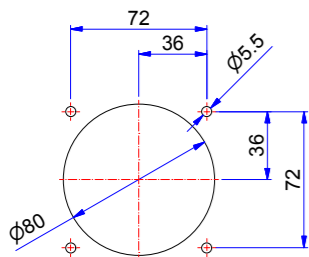

**CS6P 2500 A (neutro \_neutral 1250 A)**

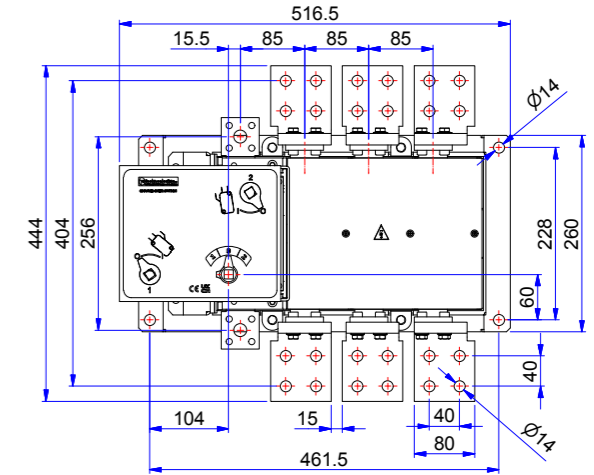

Foratura portella \_Door drilling

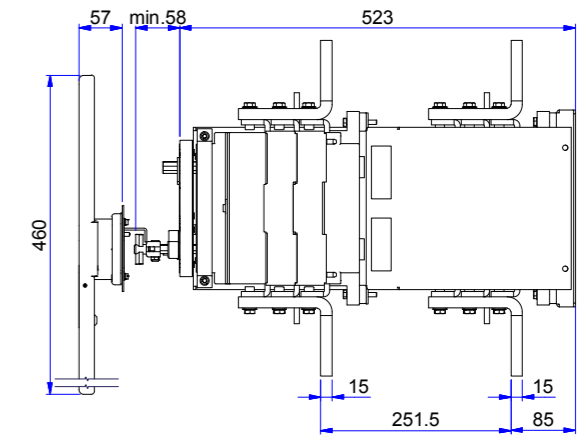
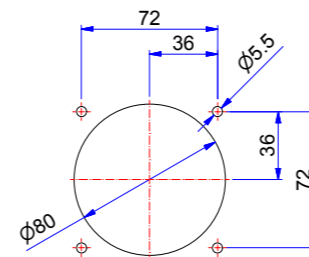

**CS6P FN 2500 A**

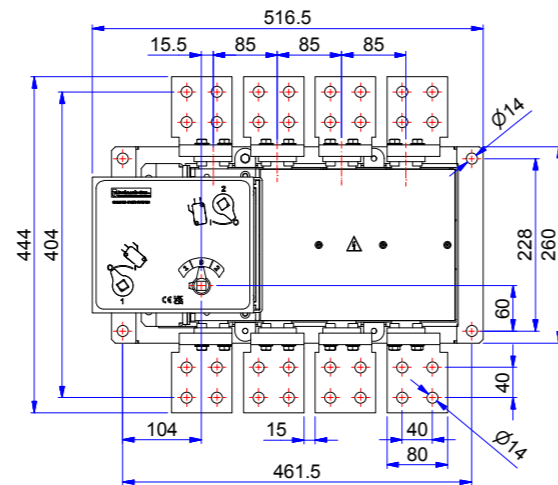

Foratura portella \_Door drilling

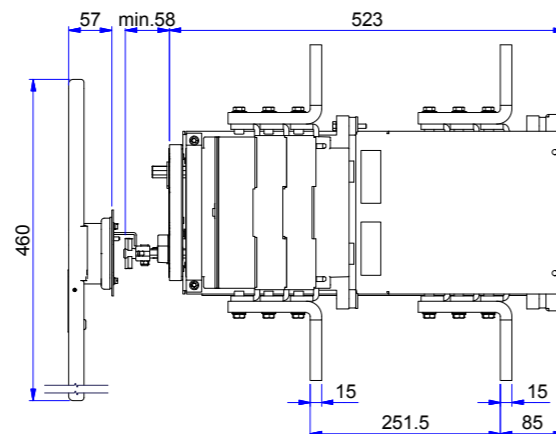
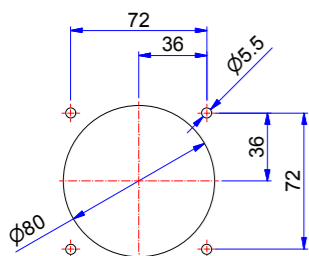

**CS6P 3150 A**

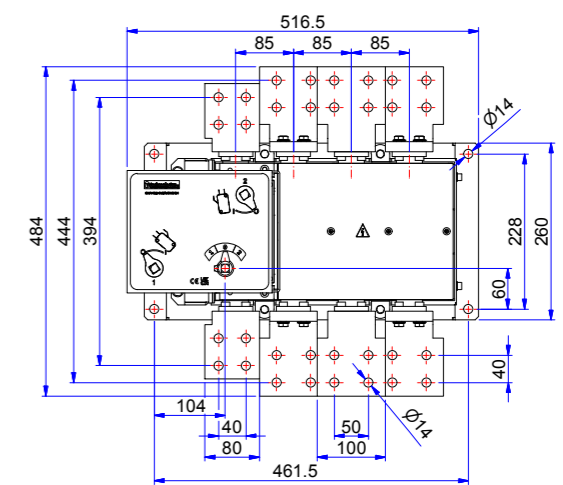

Foratura portella \_Door drilling

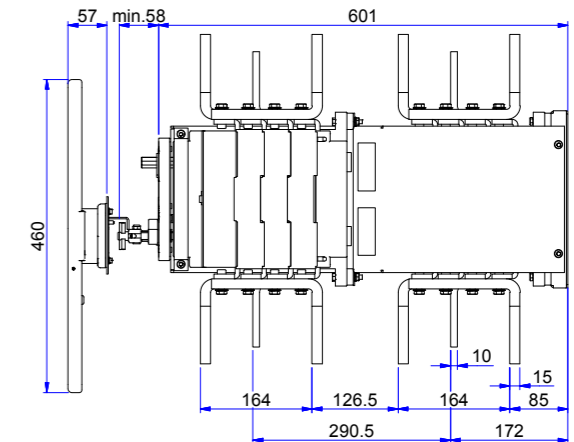
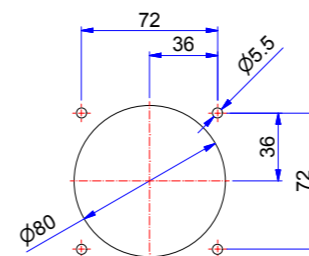

**CO1P 32 - 160 A**

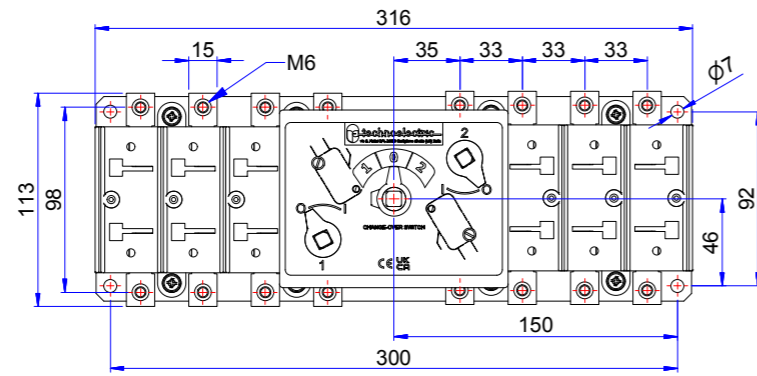

Foratura portella \_Door drilling

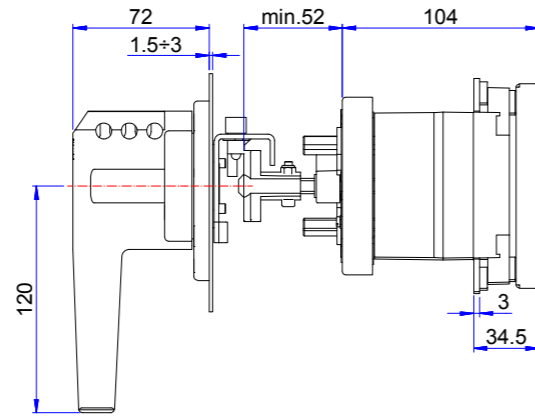
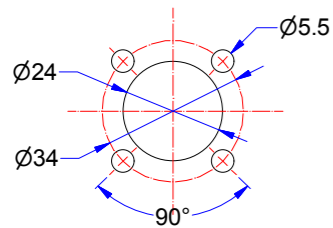

**CO3P 315 - 500 A**

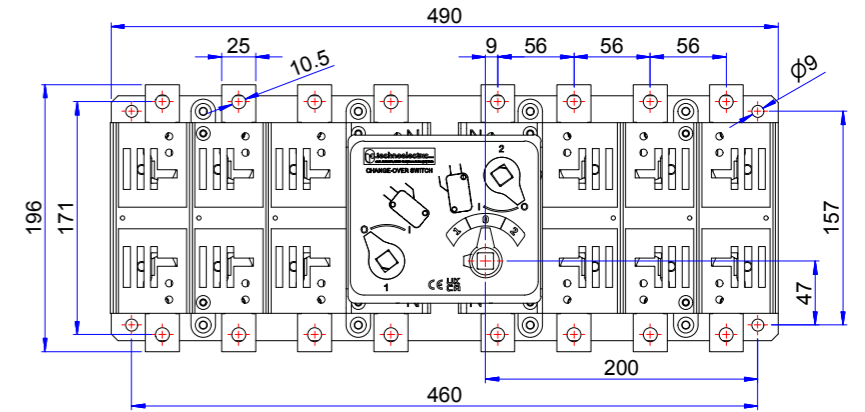

Foratura portella \_Door drilling

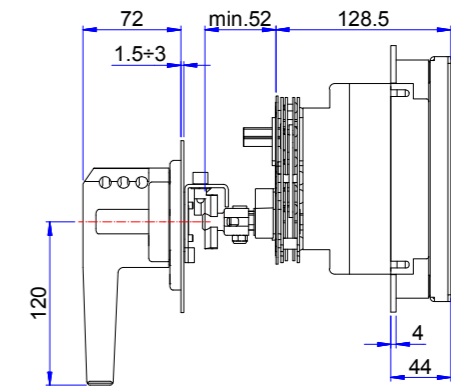
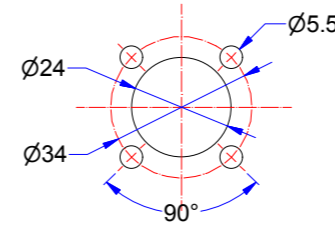

**CO2P 160 - 315 A**

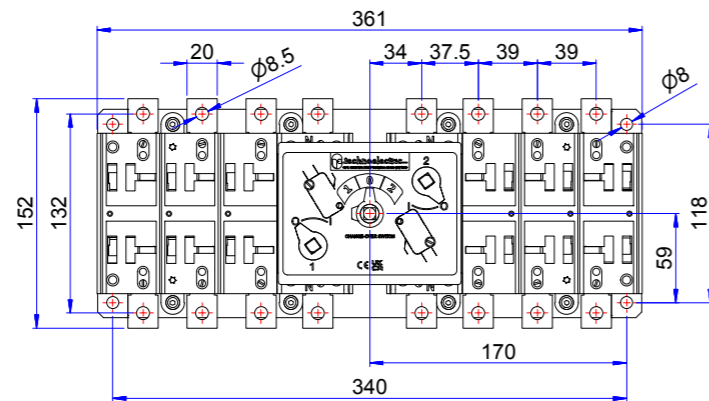
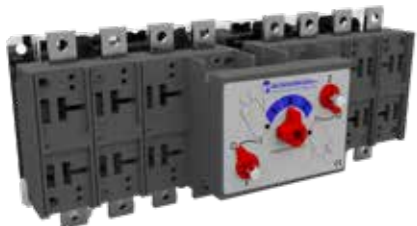

Foratura portella \_Door drilling

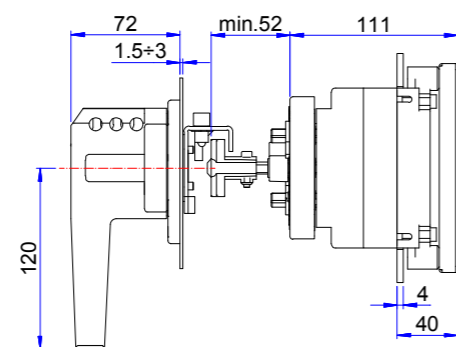
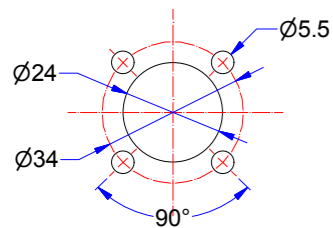

**CO4P 630 - 800 A**

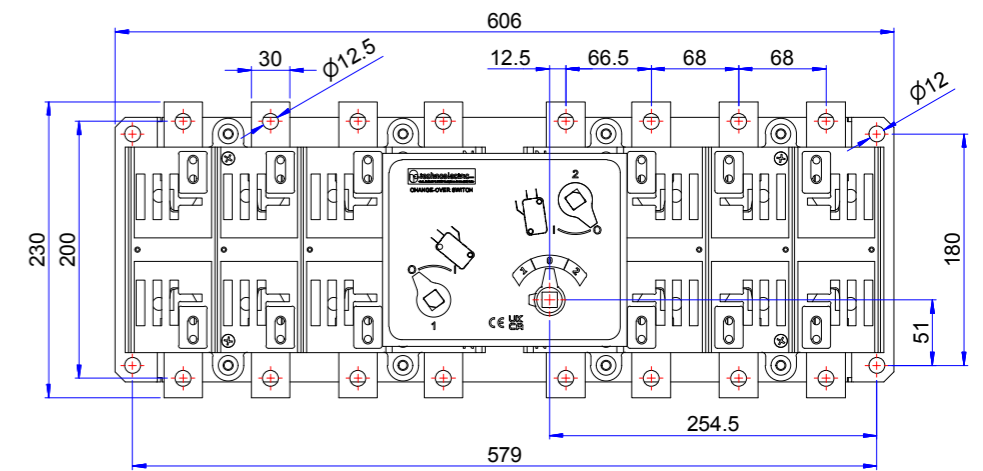

Foratura portella \_Door drilling

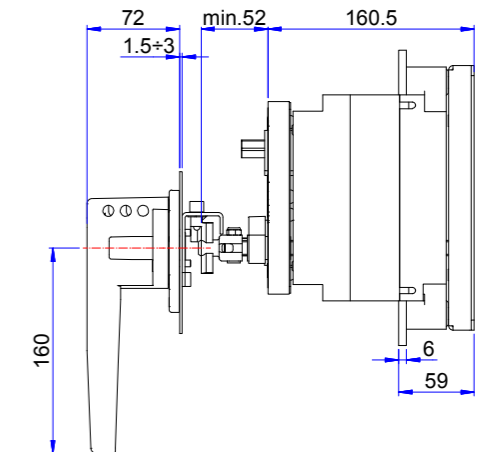
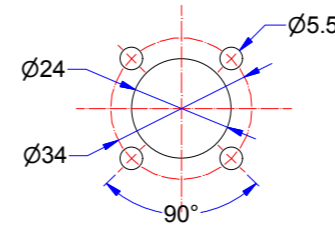

**CO5P 800 ÷ 1250 A**

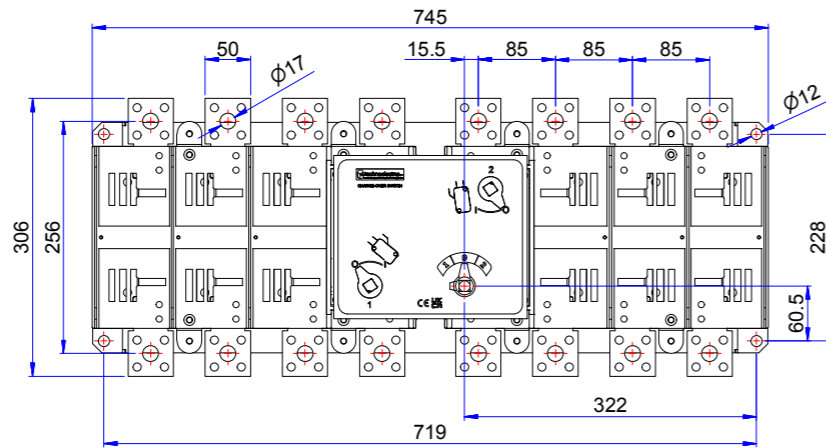

Foratura portella \_Door drilling

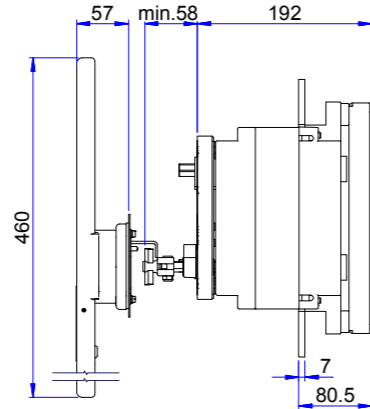
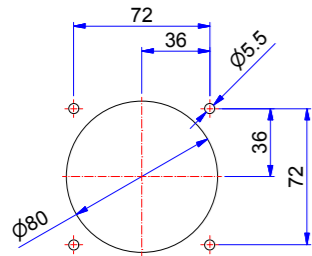

**CO5P 2500 ÷ 3150 A**

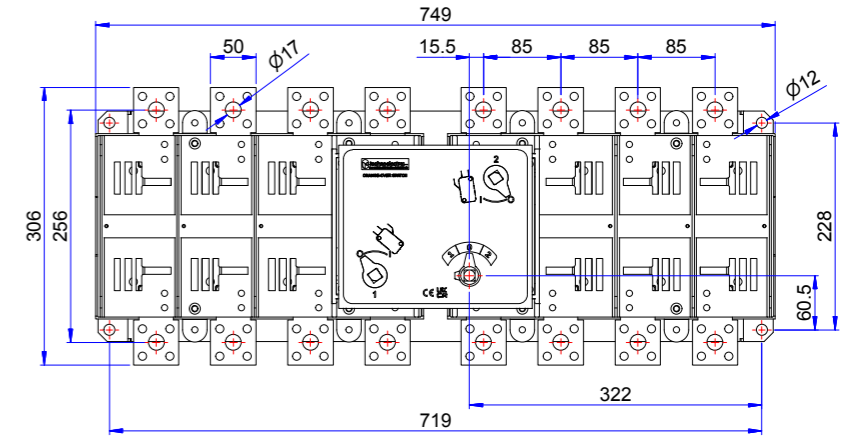

Foratura portella \_Door drilling

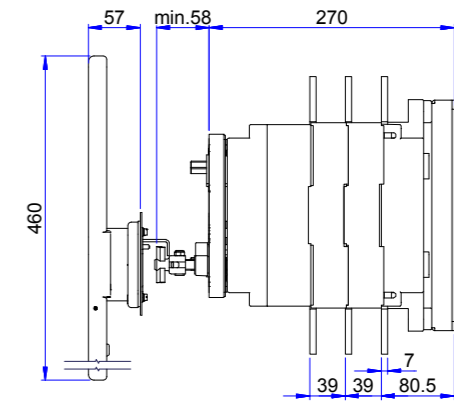
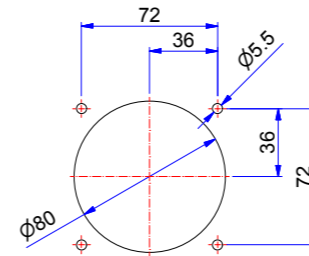

**CO5P 1600 ÷ 2000 A**

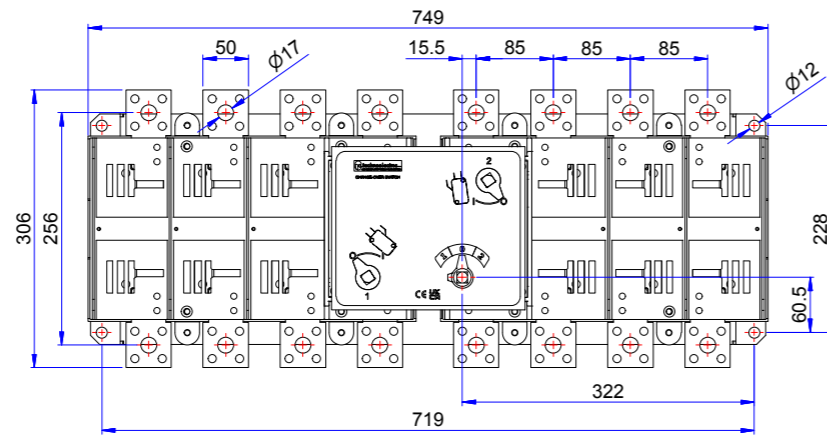

Foratura portella \_Door drilling

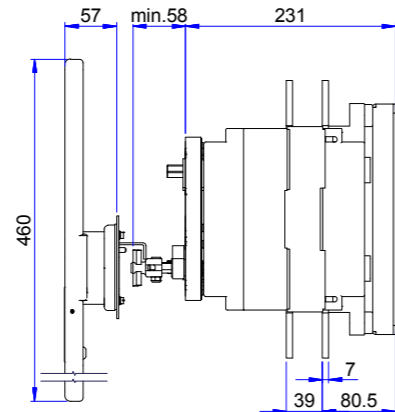
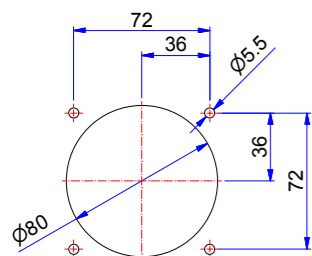

**CO6P 1600 A (neutro \_neutral 1250 A)**

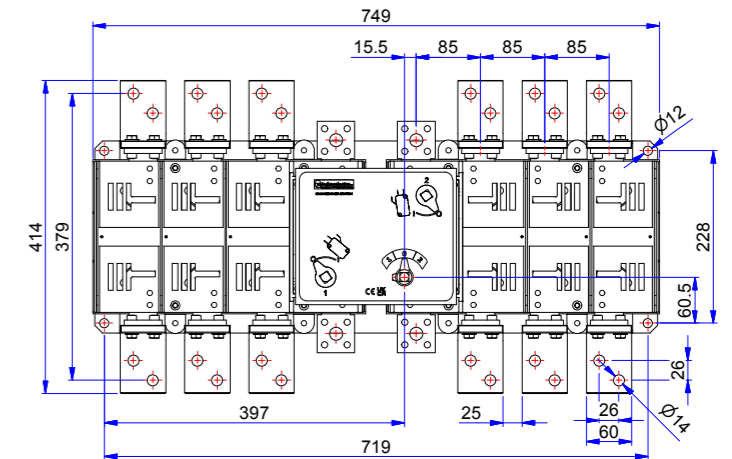

Foratura portella \_Door drilling

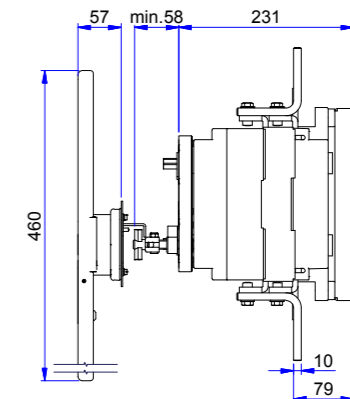
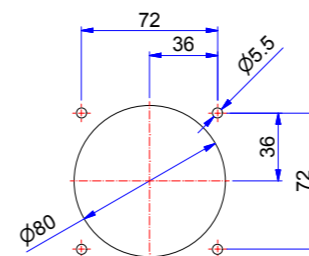



**CO6P FN 1600 A**

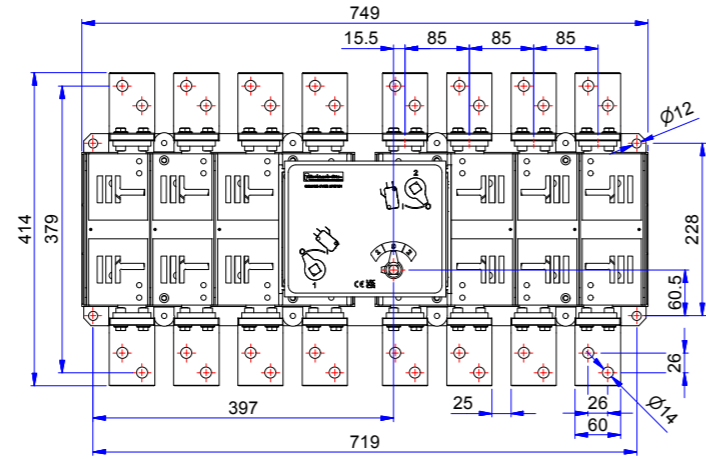

Foratura portella \_Door drilling

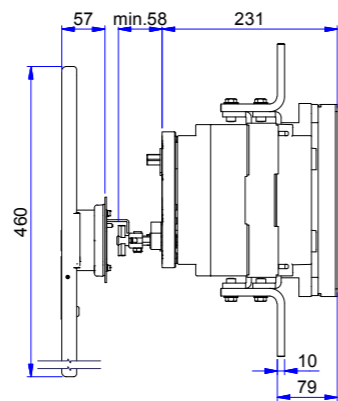
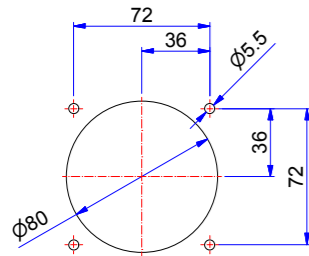

**CO6P FN 2000 A**

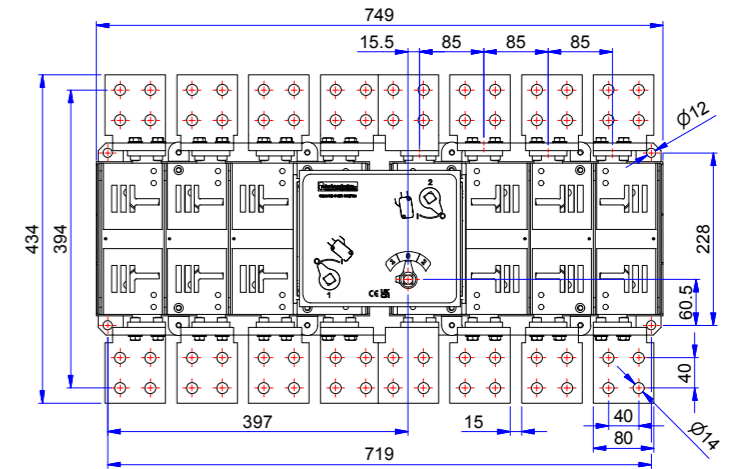

Foratura portella \_Door drilling

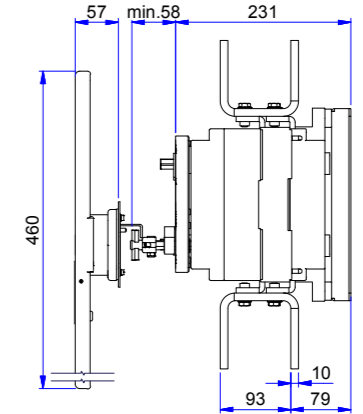
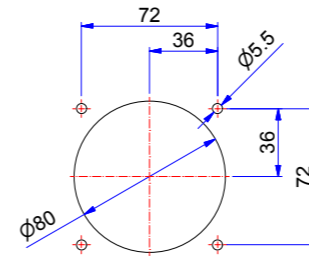

**CO6P 2000 A (neutro \_neutral 1250 A)**

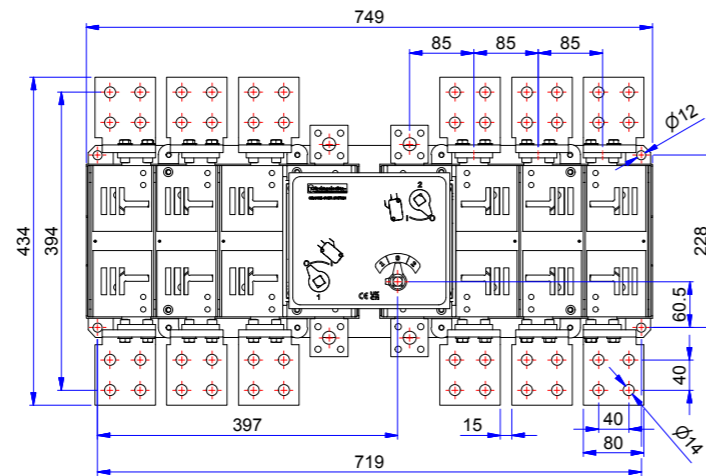

Foratura portella \_Door drilling

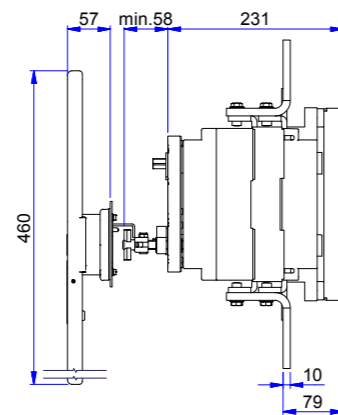
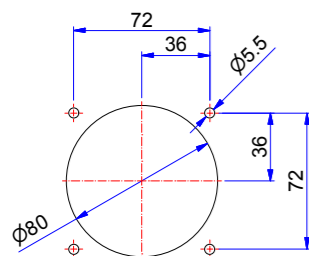

**CO6P 2500 A (neutro \_neutral 1250 A)**

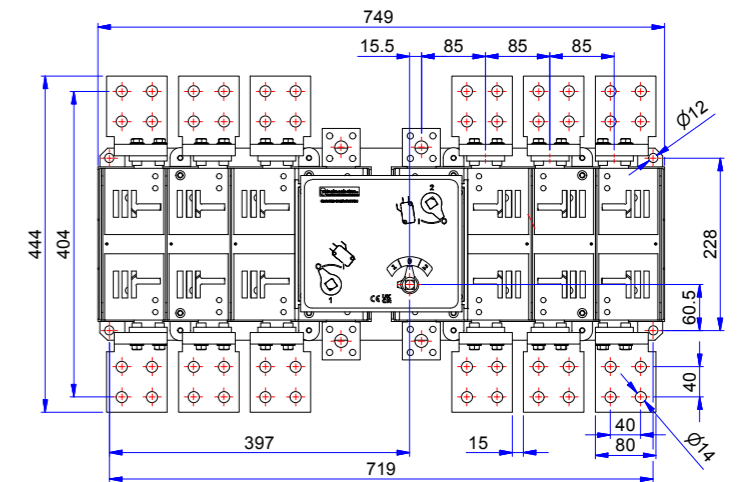

Foratura portella \_Door drilling

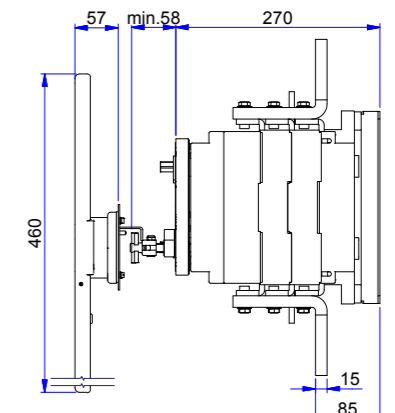
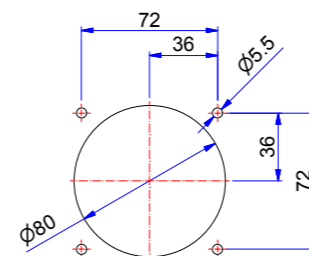

**CO6P FN 2500 A**

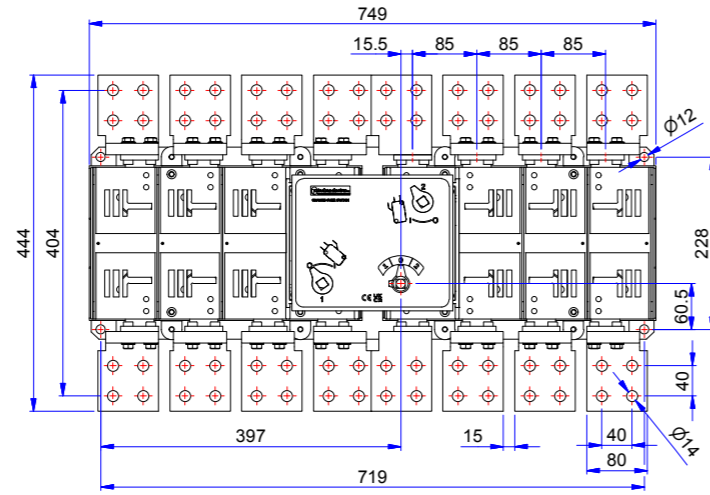

Foratura portella \_Door drilling

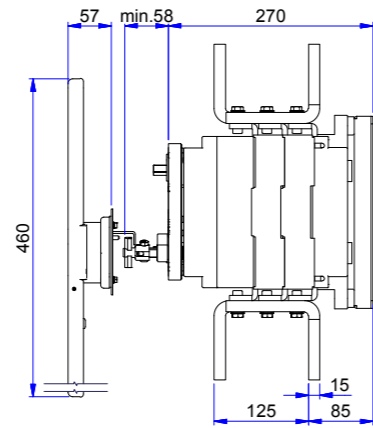
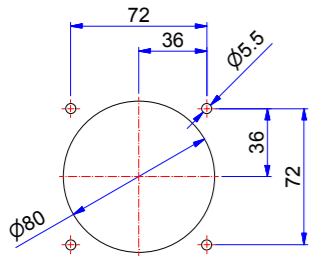

**BYP 1P 125 A**

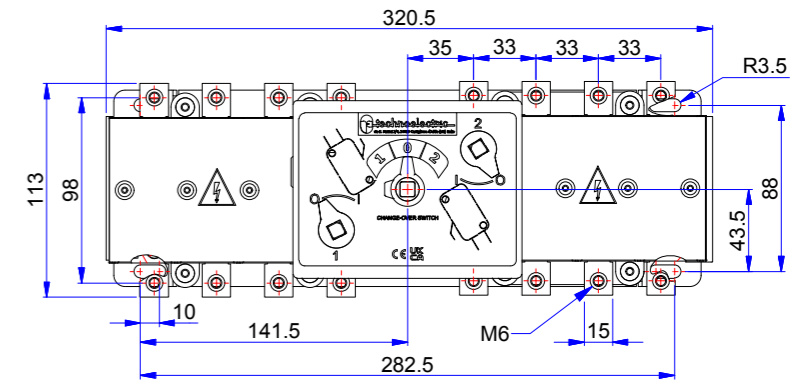
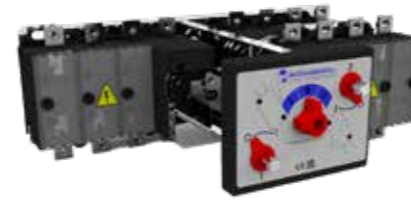

Foratura portella \_Door drilling

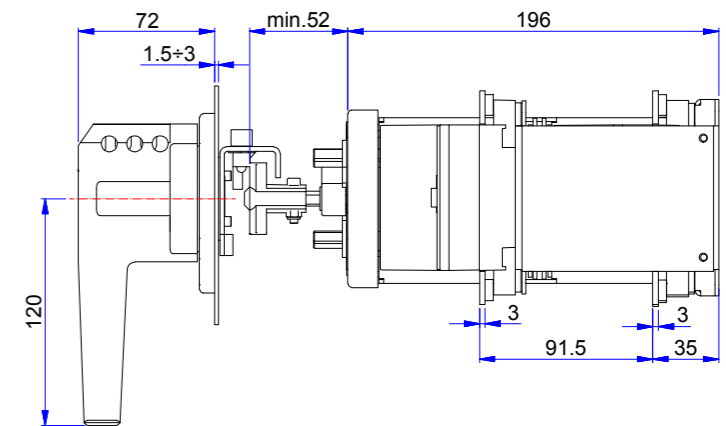
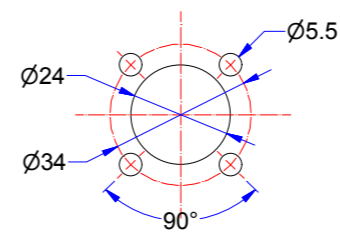

**CO6P 3150 A**

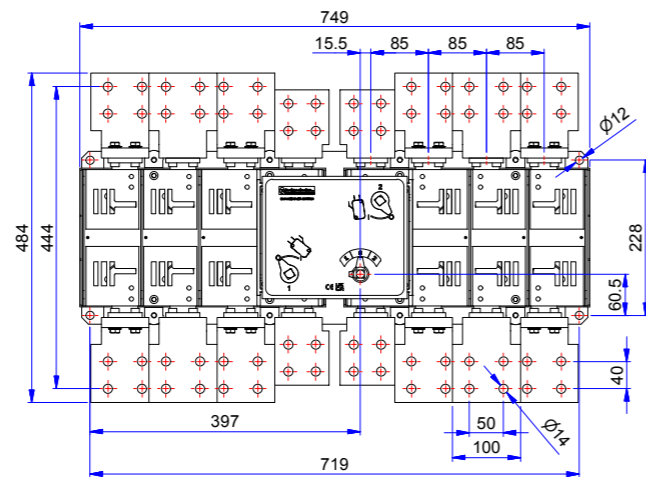
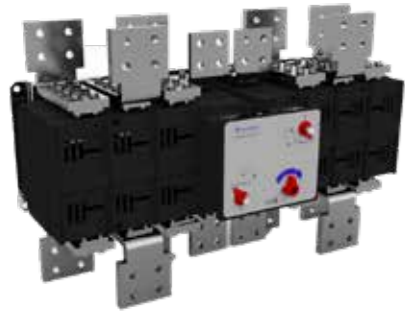

Foratura portella \_Door drilling

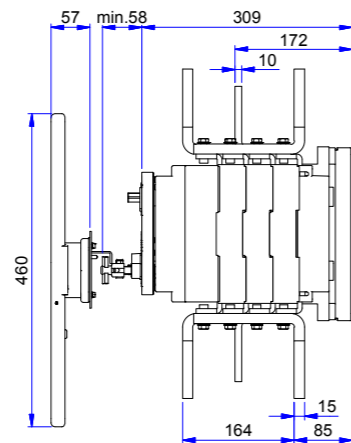
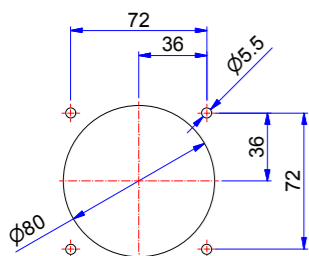

**BYP 2P 250 A**

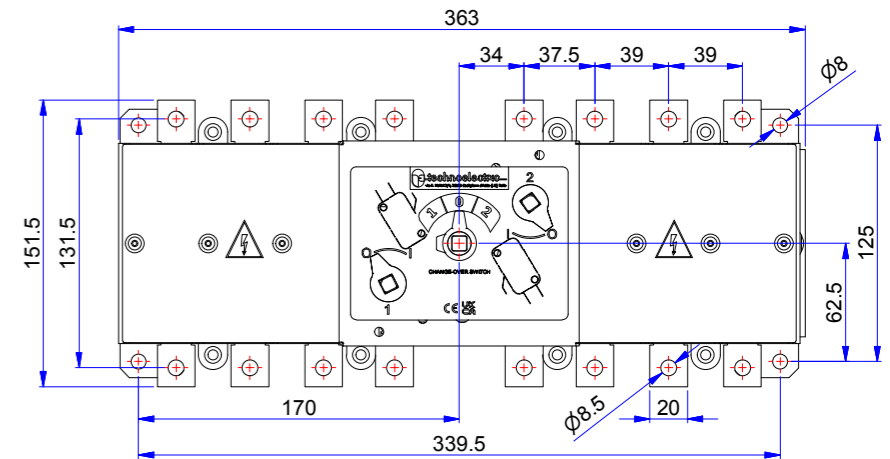

Foratura portella \_Door drilling

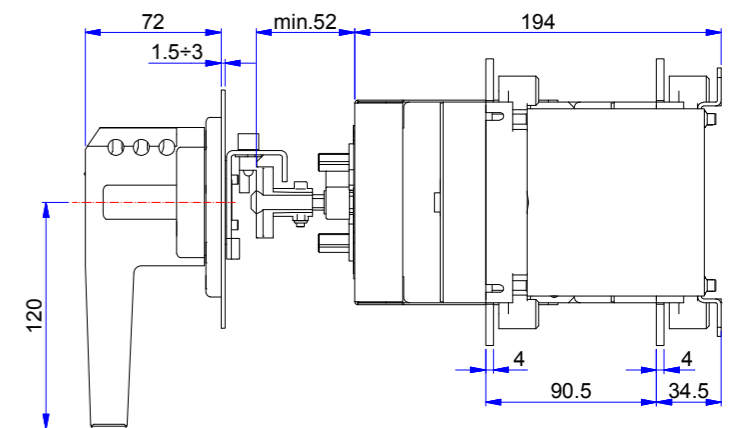
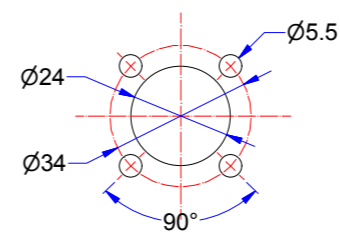

**BYP 3P 400 A**

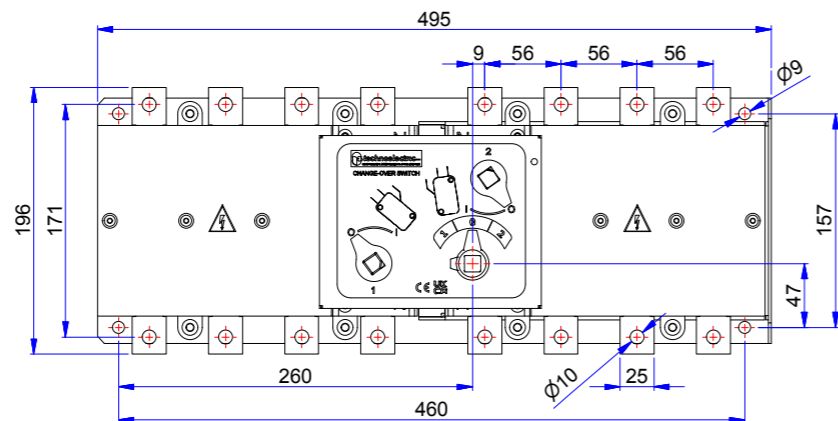

Foratura portella \_Door drilling

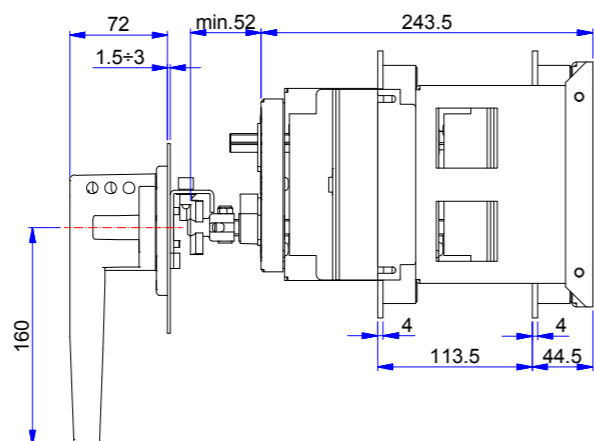
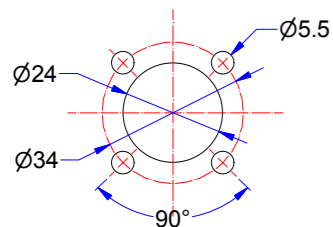

**BYP 5P 1250 A**

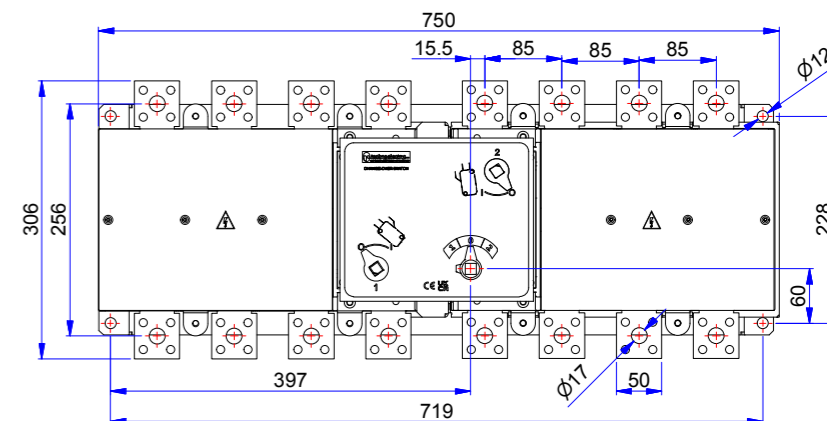

Foratura portella \_Door drilling

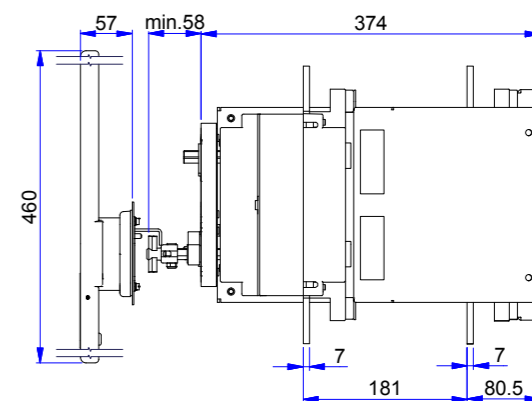
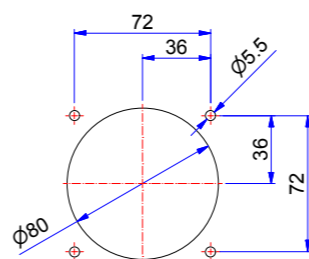

**BYP 4P 800 A**

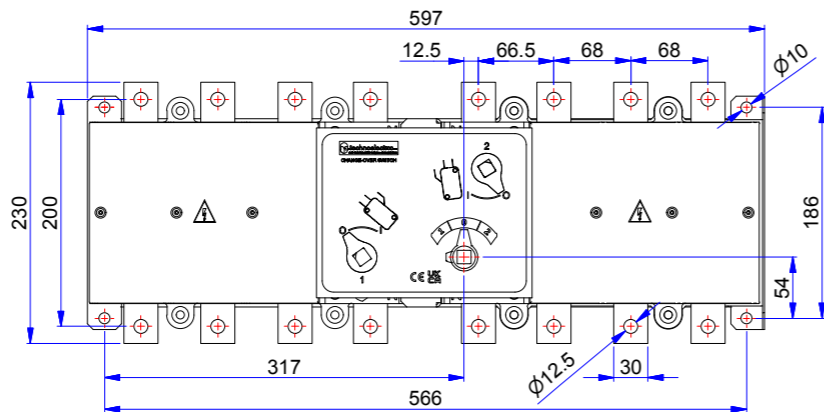

Foratura portella \_Door drilling

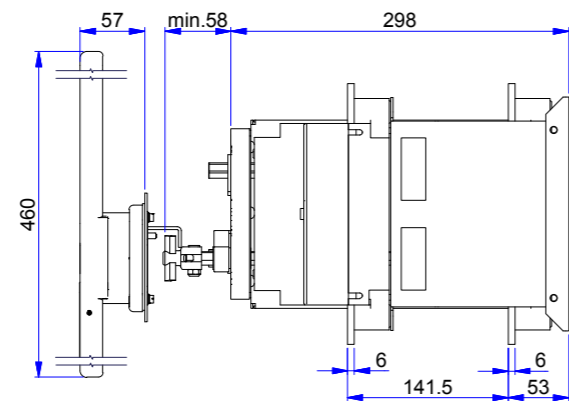
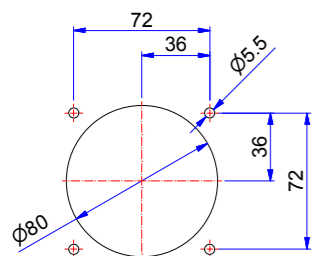

**Commutatori 6-8 poli**  
\_6-8 poles change-over switches



Tipo _type	Corrente nominale _rated current	Senza maniglia _without handle		Maniglia blocco porta _door interlock handle	
		POLI _POLES	CODICE _CODES	POLI _POLES	CODICE _CODES
<b>CO1P</b>	32 A	6P	1100032SM	6P	1100032
		8P	1101032SM	8P	1101032
	45A	6P	1100132SM	6P	1100132
		8P	1101132SM	8P	1101132
	63A	6P	1100232SM	6P	1100232
		8P	1101232SM	8P	1101232
	80A	6P	1100332SM	6P	1100332
		8P	1101332SM	8P	1101332
	100A	6P	1100432SM	6P	1100432
		8P	1101432SM	8P	1101432
	125A	6P	1100532SM	6P	1100532
		8P	1101532SM	8P	1101532
160A	6P	1100632SM	6P	1100632	
	8P	1101632SM	8P	1101632	
<b>CO2P</b>	160A	6P	1200132SM	6P	1200132
		8P	1201132SM	8P	1201132
	200A	6P	1200232SM	6P	1200232
		8P	1201232SM	8P	1201232
	250A	6P	1200332SM	6P	1200332
		8P	1201332SM	8P	1201332
	315A	6P	1200432SM	6P	1200432
		8P	1201432SM	8P	1201432
	315A	6P	1300132SM	6P	1300132
		8P	1301132SM	8P	1301132
	400A	6P	1300232SM	6P	1300232
		8P	1301232SM	8P	1301232
500A	6P	1300332SM	6P	1300332	
	8P	1301332SM	8P	1301332	
630A	6P	1400332SM	6P	1400332	
	8P	1401332SM	8P	1401332	
800A	6P	1400432SM	6P	1400432	
	8P	1401432SM	8P	1401432	
800A	6P	1500032SM	6P	1500032	
	8P	1501032SM	8P	1501032	
1000A	6P	1500132SM	6P	1500132	
	8P	1501132SM	8P	1501132	
1250A	6P	1500232SM	6P	1500232	
	8P	1501232SM	8P	1501232	

**CO1P 32 ÷ 160 A**

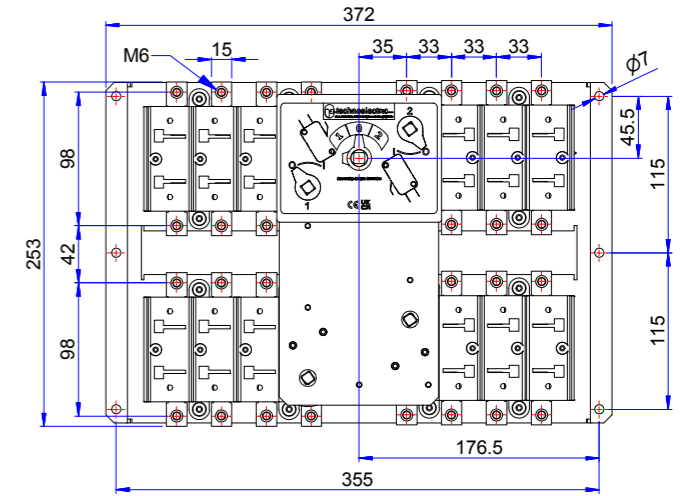

Foratura portella \_Door drilling

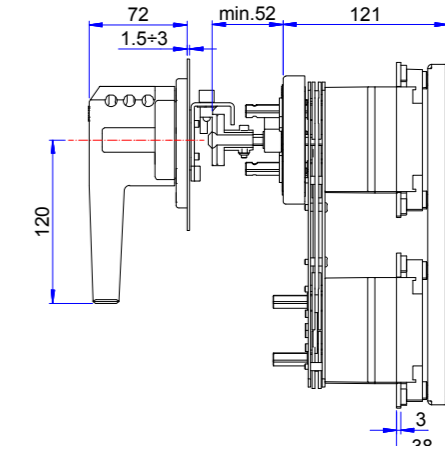
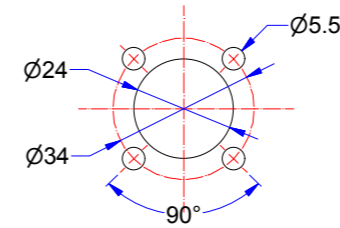

**CO2P 160 ÷ 315 A**

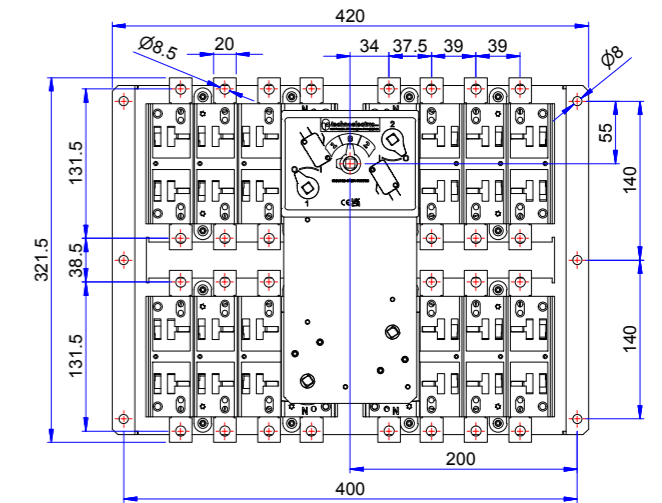

Foratura portella \_Door drilling

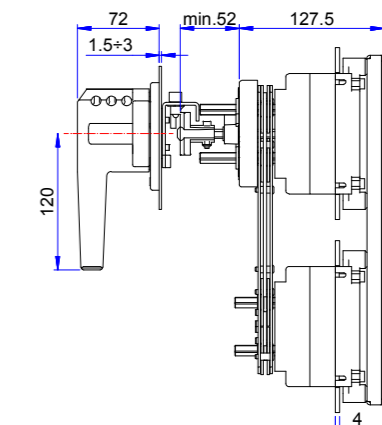
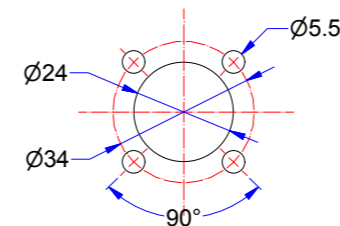



CO3P 315 ÷ 500 A

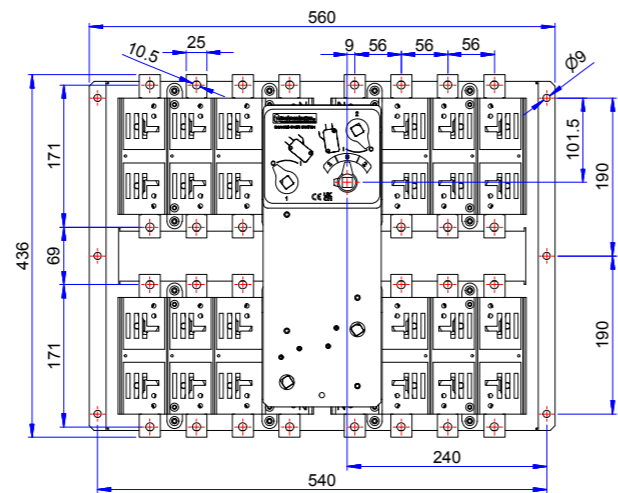
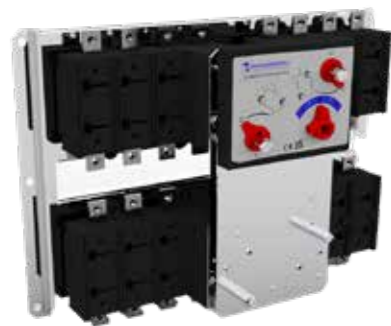

Foratura portella \_Door drilling

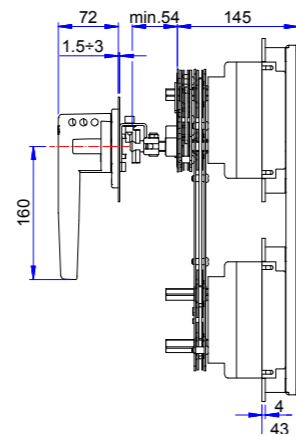
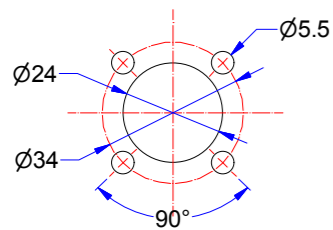

CO5P 800 ÷ 1250 A

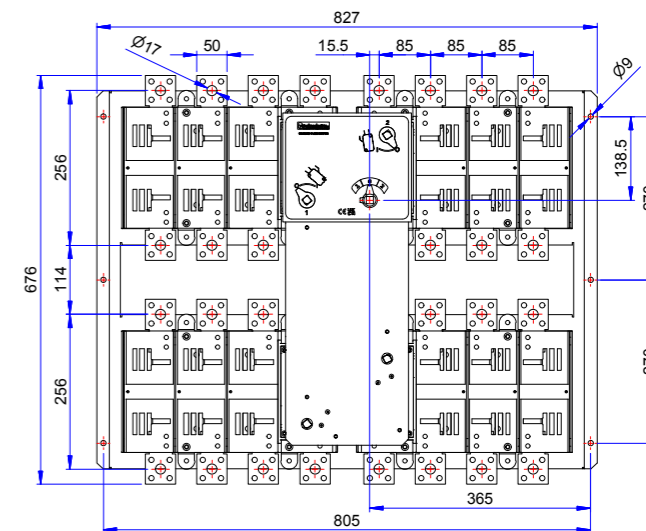

Foratura portella \_Door drilling

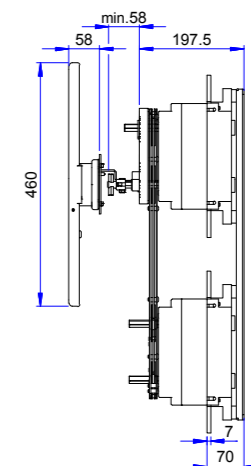
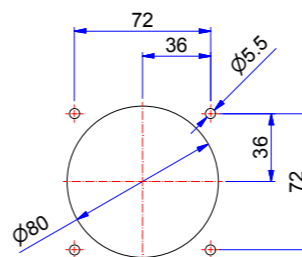

CO4P 630 ÷ 800 A

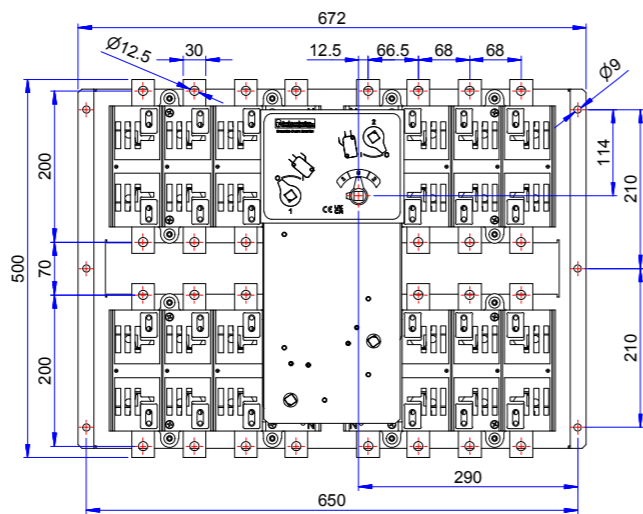

Foratura portella \_Door drilling

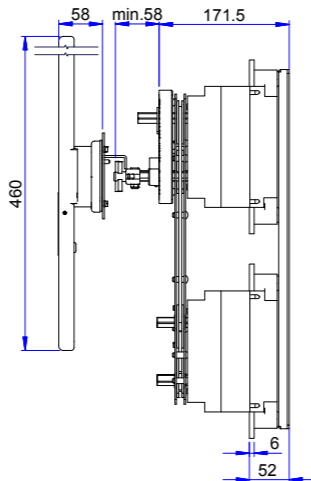
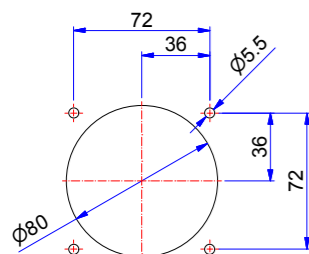

# COP overlapping

Commutatori orizzontali senza zero overlapping  
\_overlapping without zero change-over switches horizontal execution



Tipo _type	Corrente _rated current	Maniglia blocco porta _door interlock handle	
		POLI _POLES	CODICE _CODES
<b>CO1P</b>	32 A	3	110003OL
		4	110103OL
	45A	3	110013OL
		4	110113OL
	63A	3	110023OL
		4	110123OL
	80A	3	110033OL
		4	110133OL
	100A	3	110043OL
		4	110143OL
	125A	3	110053OL
		4	110153OL
160A	3	110063OL	
	4	110163OL	
<b>CO2P</b>	160A	3	120013OL
		4	120113OL
	200A	3	120023OL
		4	120123OL
	250A	3	120033OL
		4	120133OL
315A	3	120043OL	
	4	120143OL	
<b>CO3P</b>	315A	3	130013OL
		4	130113OL
	400A	3	130023OL
		4	130123OL
500A	3	130033OL	
	4	130133OL	
<b>CO4P</b>	630A	3	140033OL
		4	140133OL
	800A	3	140043OL
		4	140143OL
<b>CO5P (35kA)</b>	800A	3	150003OL
		4	150103OL
	1000A	3	150013OL
		4	150113OL
	1250A	3	150023OL
		4	150123OL
<b>CO5P (50kA)</b>	800A	3	150073OL
		4	150173OL
	1000A	3	150083OL
		4	150183OL
	1250A	3	150093OL
		4	150193OL
	1600A	3	150033OL
		4	150133OL
	2000A	3	150043OL
		4	150143OL
	2500A	3	150053OL
		4	150153OL
3150A	3	150063OL	
	4	150163OL	
<b>CO6P</b>	1600A	3	160003OL
		4	160103OL
	2000A	3	160013OL
		4	160113OL
	2500A	3	160023OL
		4	160123OL
	3150A	3	160033OL
		4	160133OL

# CSP overlapping

Commutatori sovrapposti senza zero overlapping  
\_overlapping whitout zero change-over switches two layers execution

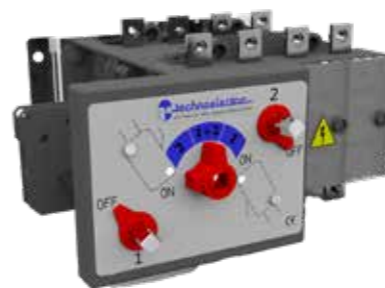

Tipo _type	Corrente _rated current	Maniglia blocco porta _door interlock handle	
		POLI _POLES	CODICE _CODES
<b>CS1P</b>	32 A	3	110008OL
		4	110108OL
	45A	3	110018OL
		4	110118OL
	63A	3	110028OL
		4	110128OL
	80A	3	110038OL
		4	110138OL
	100A	3	110048OL
		4	110148OL
	125A	3	110058OL
		4	110158OL
160A	3	110068OL	
	4	110168OL	
<b>CS2P</b>	160A	3	120018OL
		4	120118OL
	200A	3	120028OL
		4	120128OL
	250A	3	120038OL
		4	120138OL
315A	3	120048OL	
	4	120148OL	
<b>CS3P</b>	315A	3	130018OL
		4	130118OL
	400A	3	130028OL
		4	130128OL
500A	3	130038OL	
	4	130138OL	
<b>CS4P</b>	630A	3	140038OL
		4	140138OL
	800A	3	140048OL
		4	140148OL
<b>CS5P (35kA)</b>	800A	3	150008OL
		4	150108OL
	1000A	3	150018OL
		4	150118OL
	1250A	3	150028OL
		4	150128OL
<b>CS5P (50kA)</b>	800A	3	150078OL
		4	150178OL
	1000A	3	150088OL
		4	150188OL
	1250A	3	150098OL
		4	150198OL
	1600A	3	150038OL
		4	150138OL
	2000A	3	150048OL
		4	150148OL
	2500A	3	150058OL
		4	150158OL
3150A	3	150068OL	
	4	150168OL	
<b>CS6P</b>	1600A	3	160008OL
		4	160108OL
	2000A	3	160018OL
		4	160118OL
	2500A	3	160028OL
		4	160128OL
	3150A	3	160038OL
		4	160138OL

**CO1P OL 32 - 160 A**

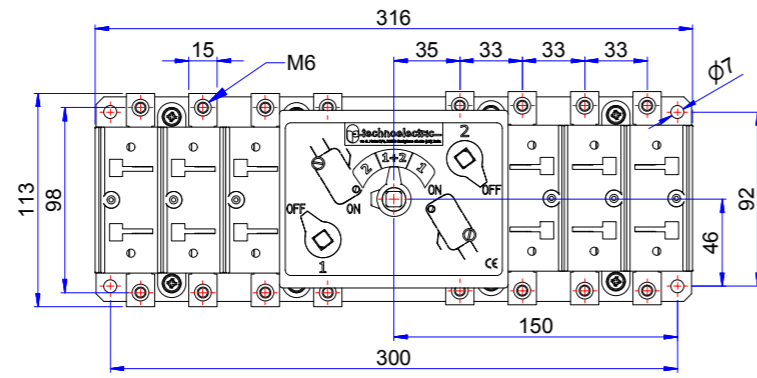

Foratura portella \_Door drilling

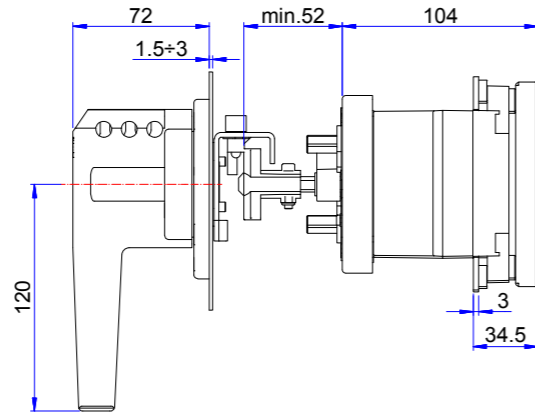
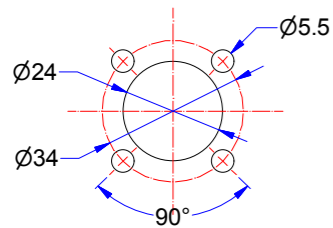

**CO3P OL 315 - 500 A**

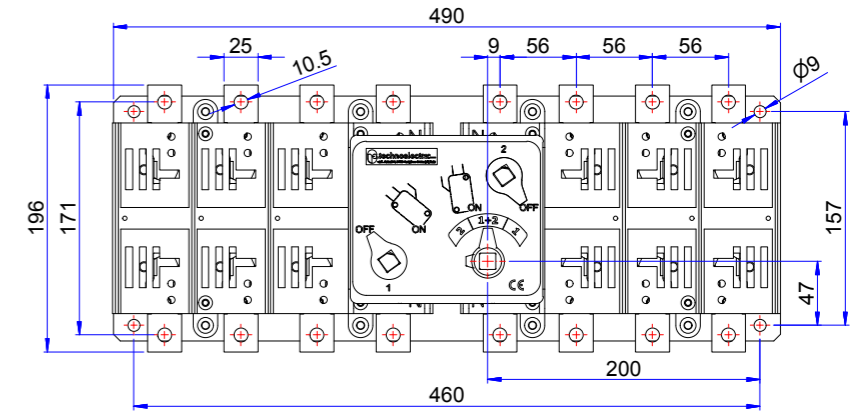

Foratura portella \_Door drilling

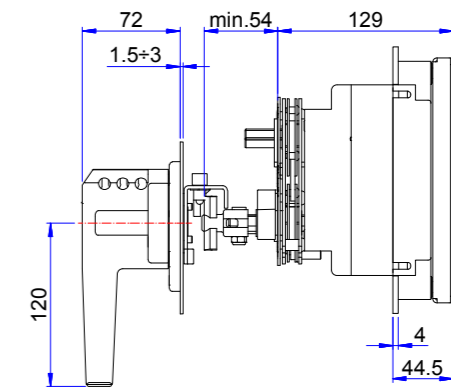
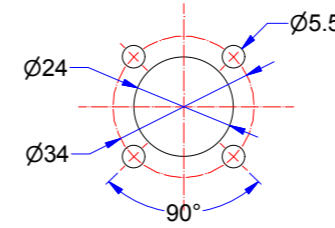

**CO2P OL 160 - 315 A**

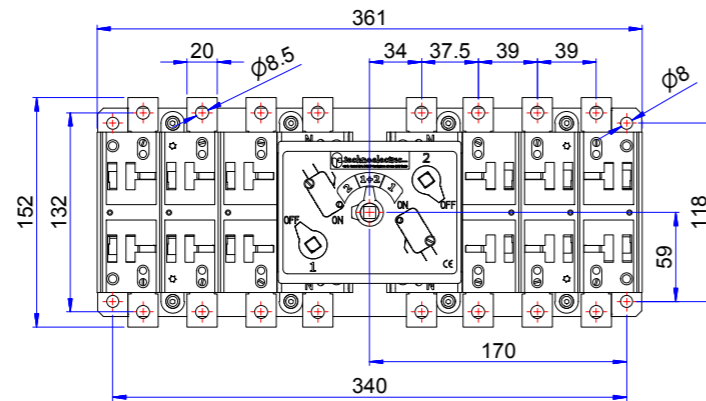
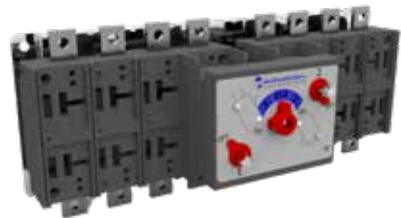

Foratura portella \_Door drilling

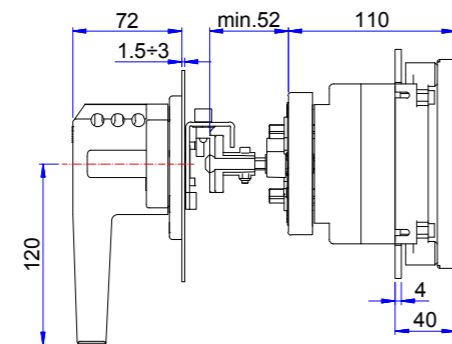
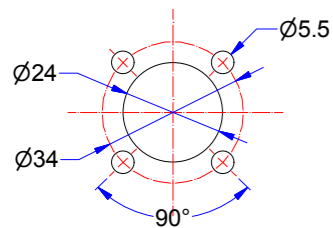

**CO4P OL 630 - 800 A**

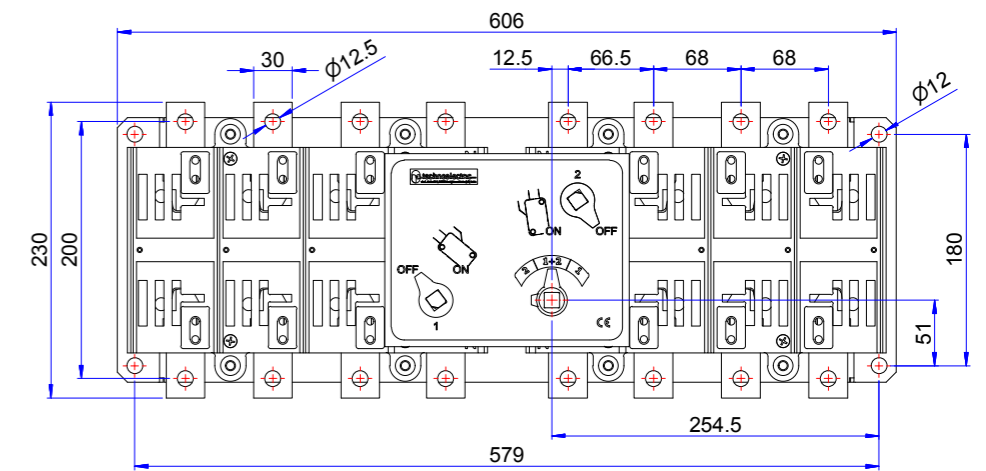

Foratura portella \_Door drilling

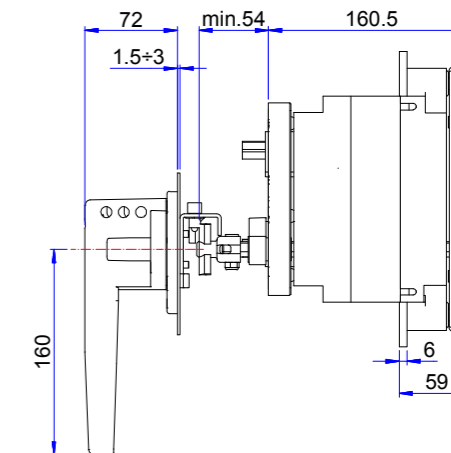
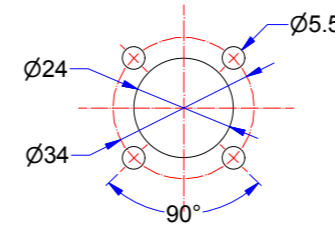

**CO5P OL 800 - 1250A 35kA**

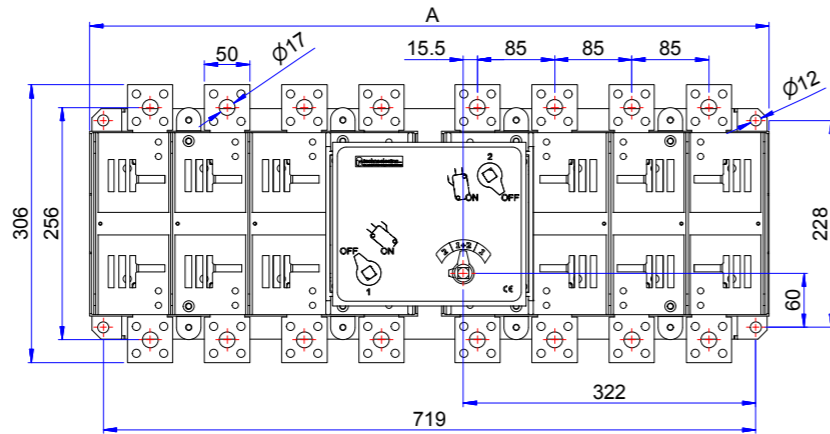

Foratura portella \_Door drilling

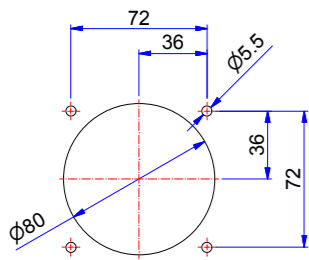

Tipo/Type	A	B	C	D
CO5P OL 800+1250A	744	192		
CO5P OL 1600+2000A	749	231	39	
CO5P OL 2500+3150A	749	270	39	39

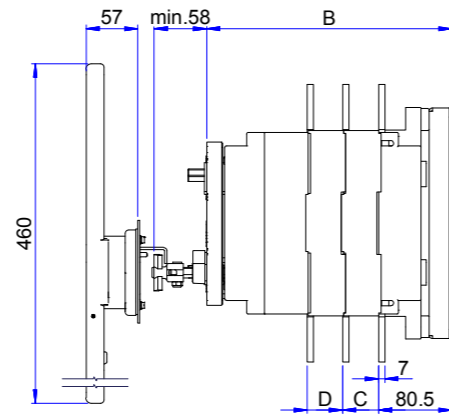

**CO6P OL 2000 A**

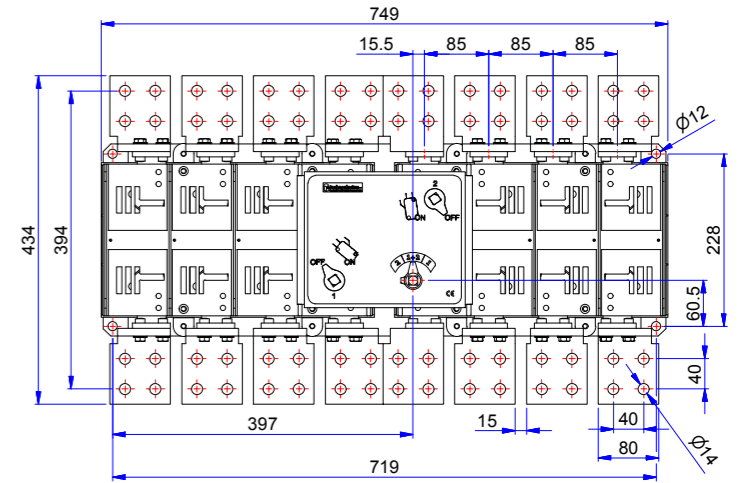

Foratura portella \_Door drilling

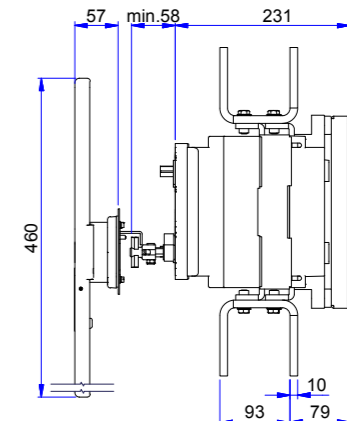
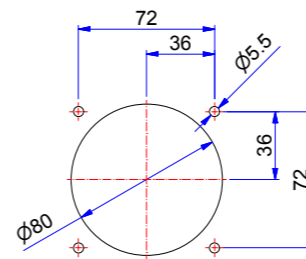

**CO6P OL 1600 A**

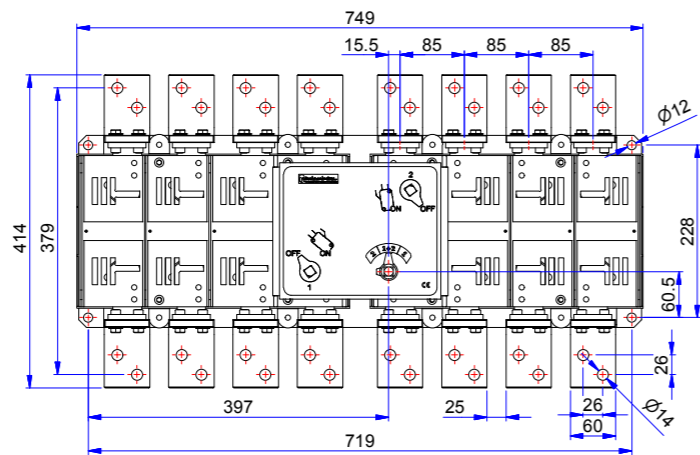
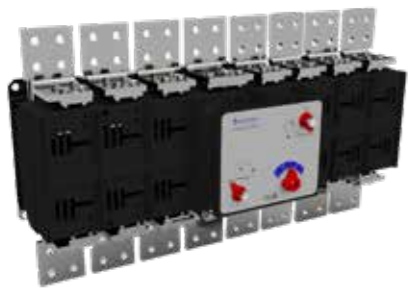

Foratura portella \_Door drilling

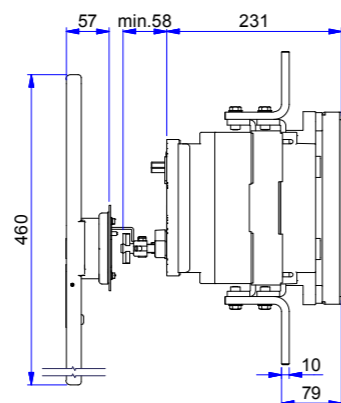
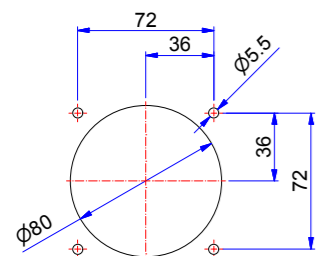

**CO6P OL 2500 A**

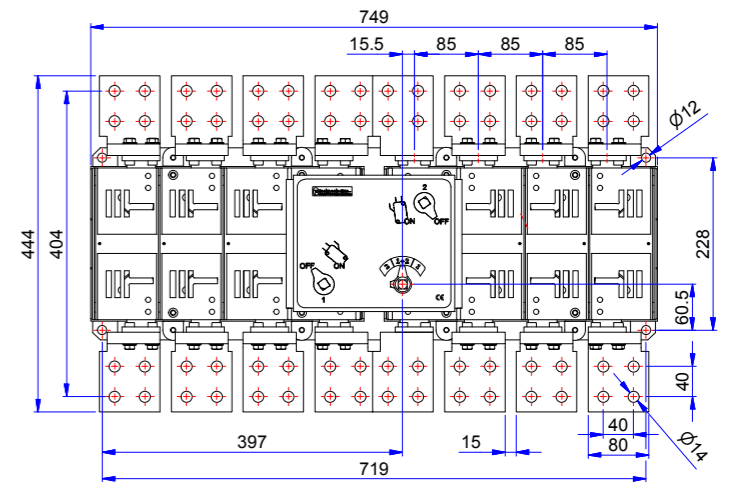
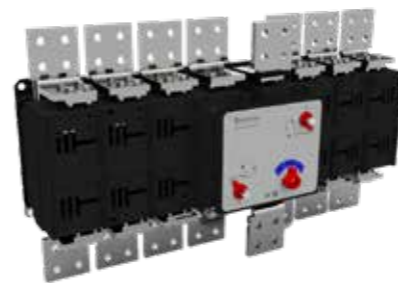

Foratura portella \_Door drilling

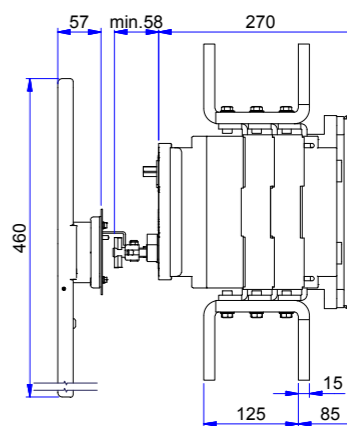
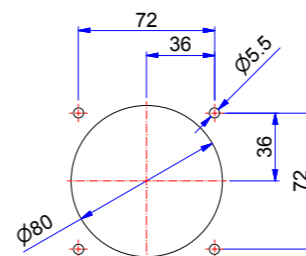



**CO6P OL 3150 A**

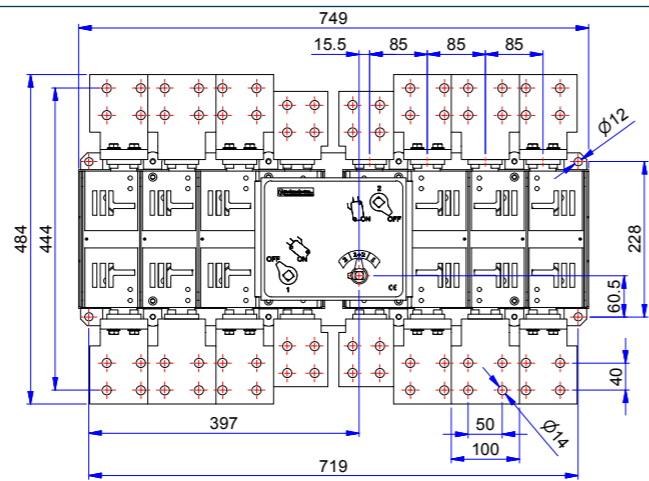

Foratura portella \_Door drilling

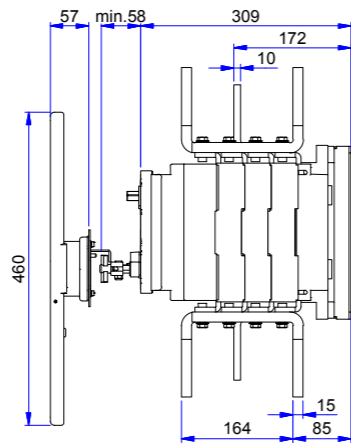
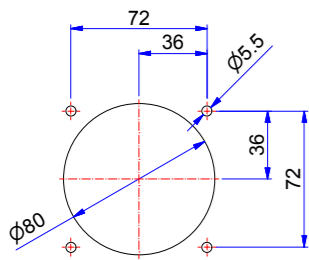

**CS2P OL 160 - 315 A**

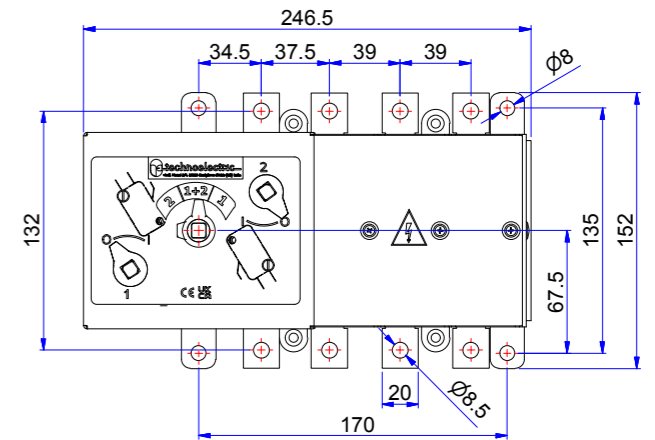

Foratura portella \_Door drilling

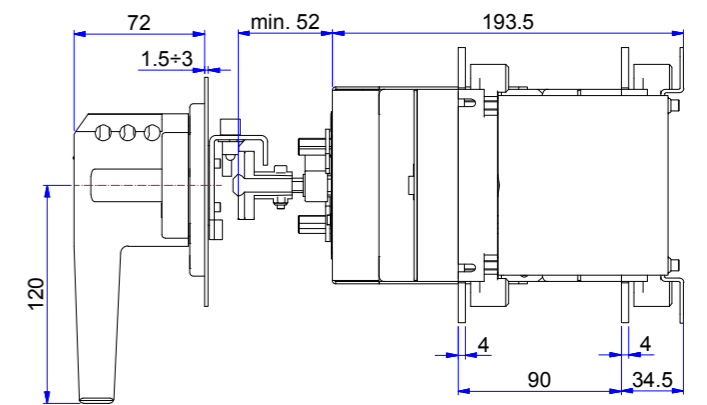
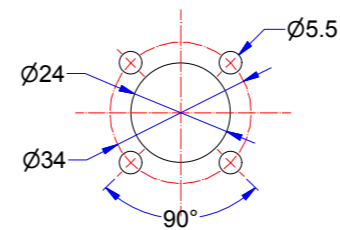

**CS1P OL 32 - 160 A**

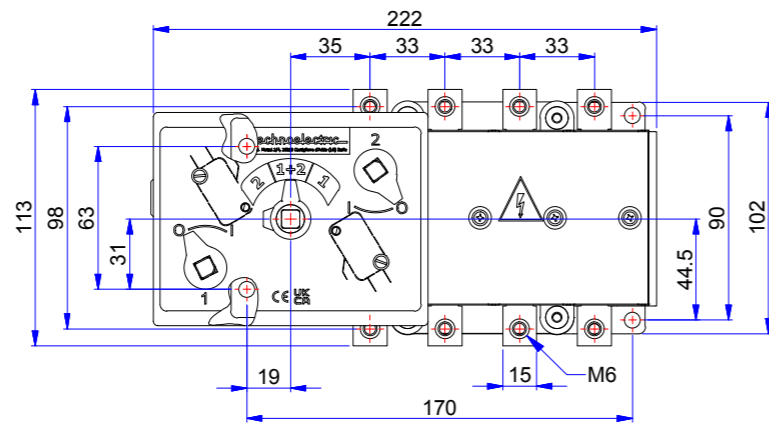

Foratura portella \_Door drilling

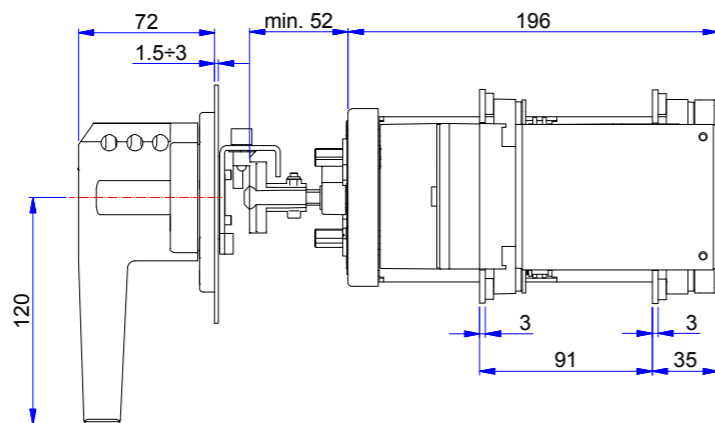
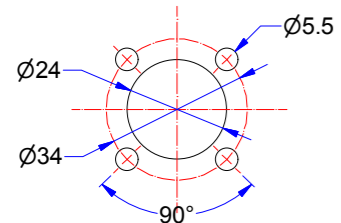

**CS3P OL 315 - 500 A**

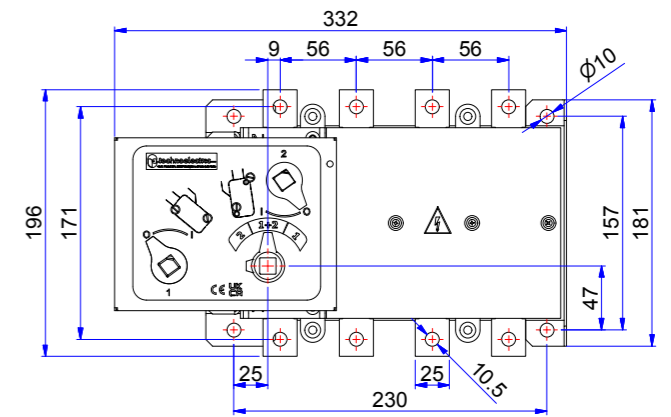

Foratura portella \_Door drilling

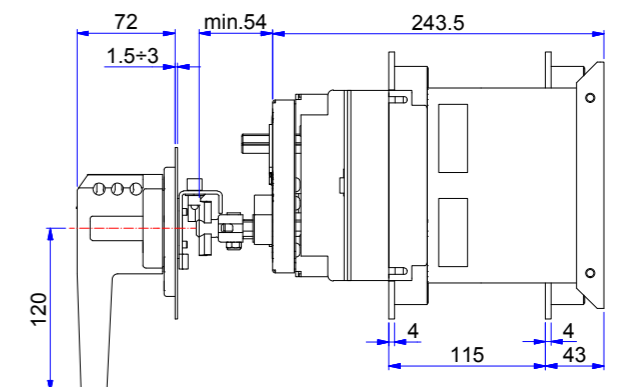
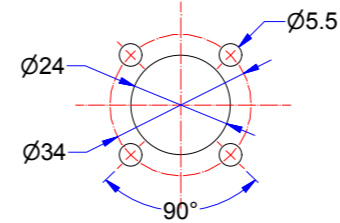

**CS4P OL 630 - 800 A**

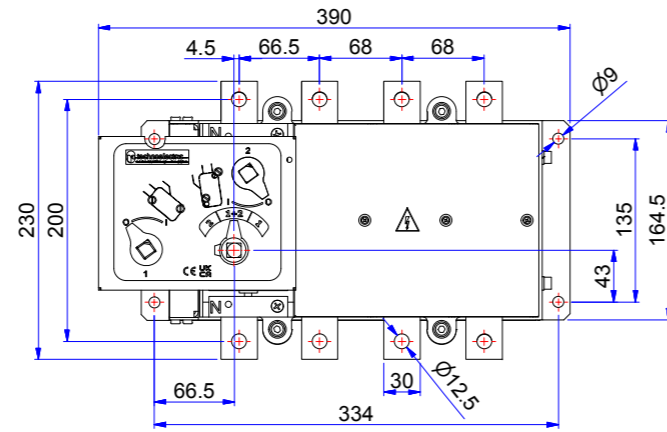

Foratura portella \_Door drilling

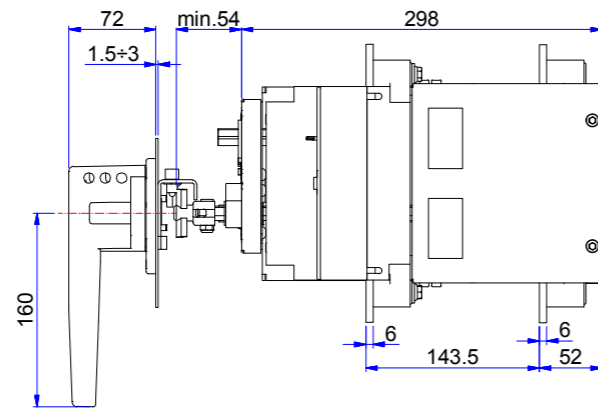
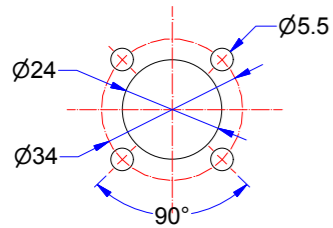

**CS5P OL 1600 ÷ 2000 A**

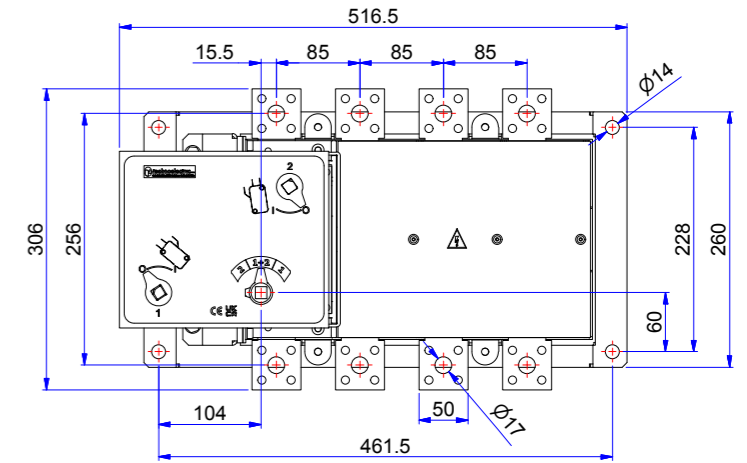

Foratura portella \_Door drilling

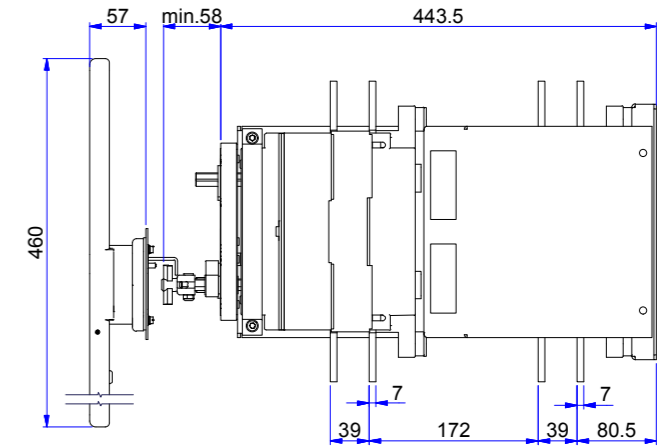
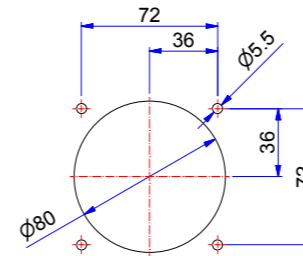

**CS5P OL 800 ÷ 1250 A**

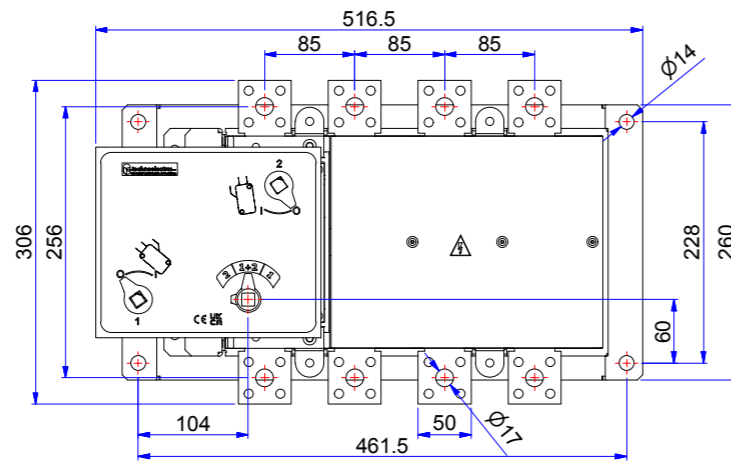
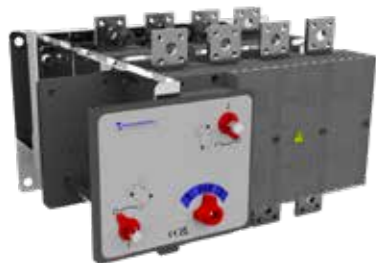

Foratura portella \_Door drilling

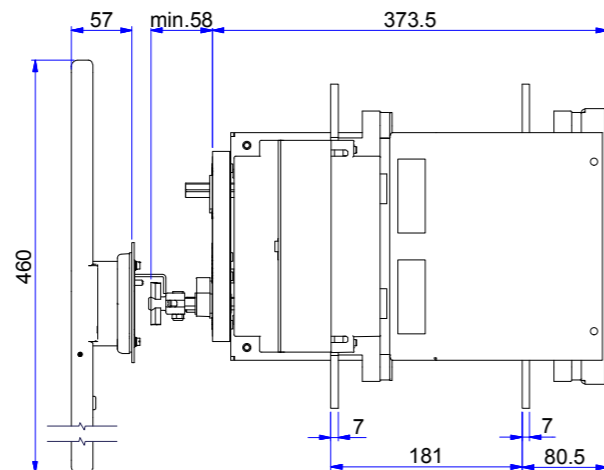
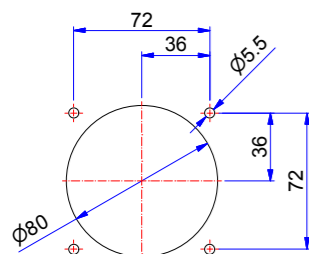

**CS5P OL 2500 ÷ 3150 A**

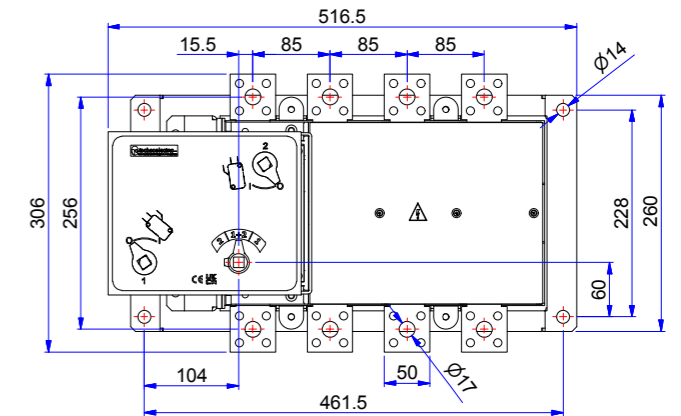

Foratura portella \_Door drilling

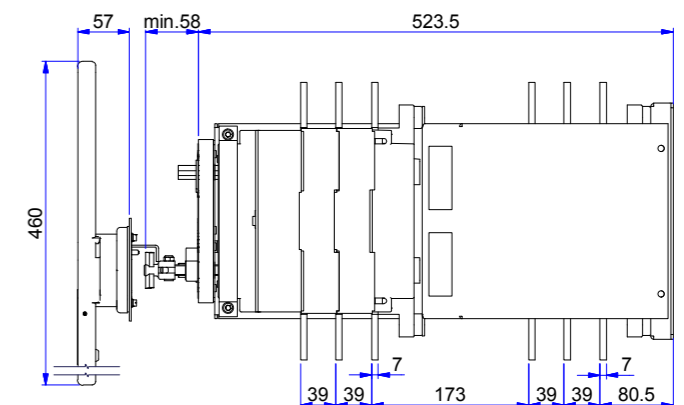
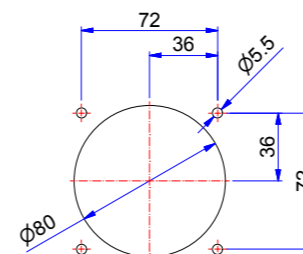

**CS6P OL 1600 A**

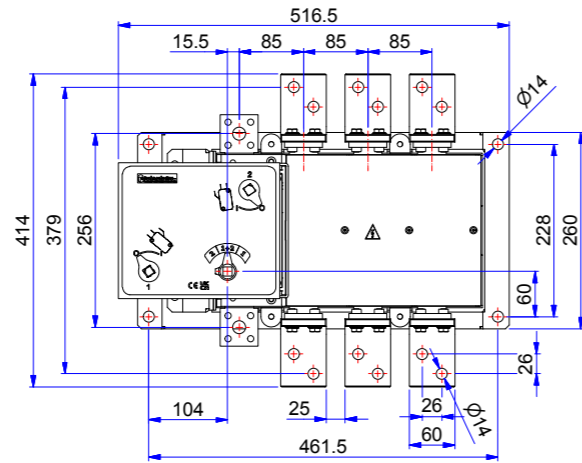

Foratura portella \_Door drilling

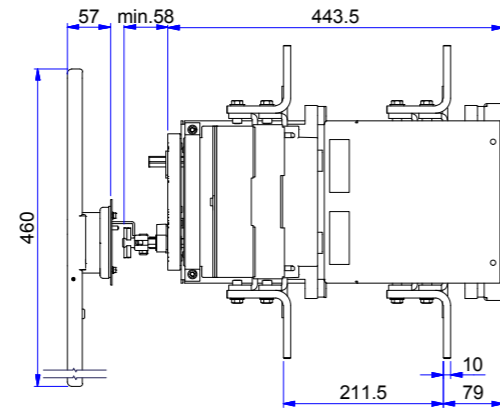
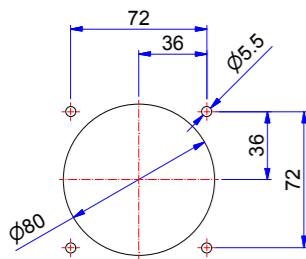

**CS6P OL 2500 A**

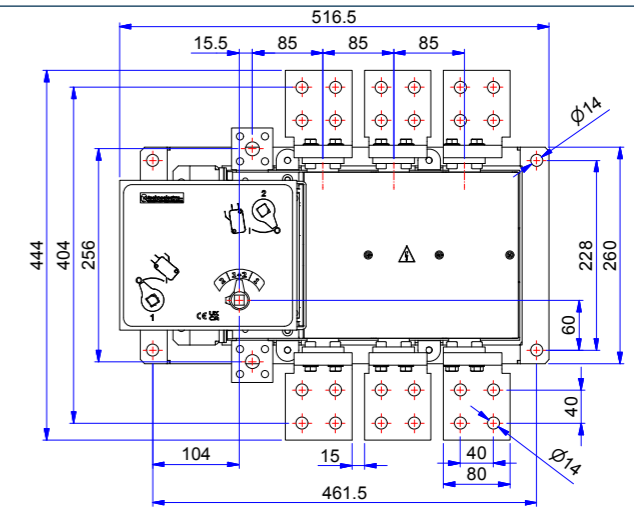

Foratura portella \_Door drilling

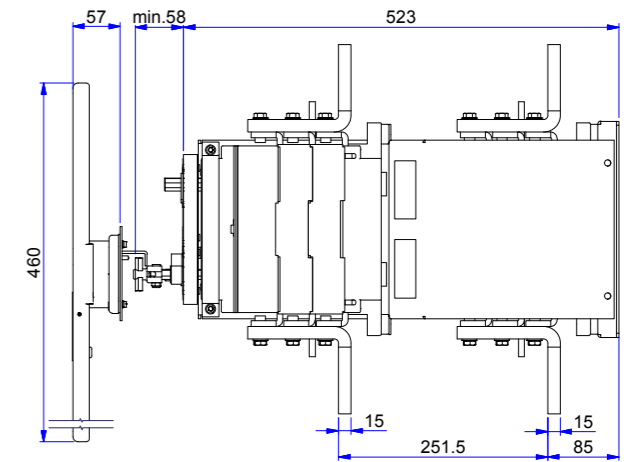
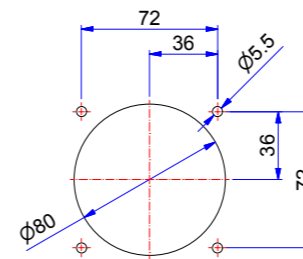

**CS6P OL 2000 A**

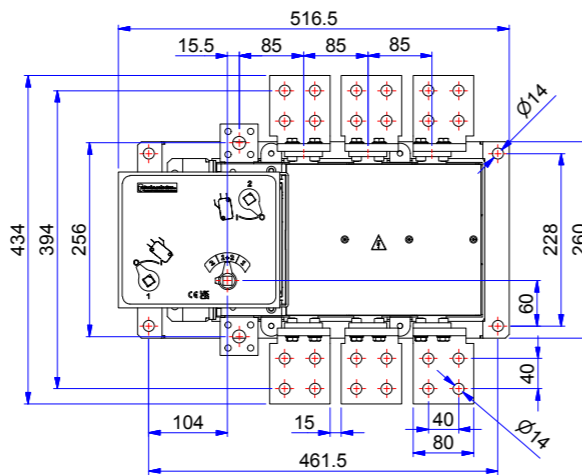

Foratura portella \_Door drilling

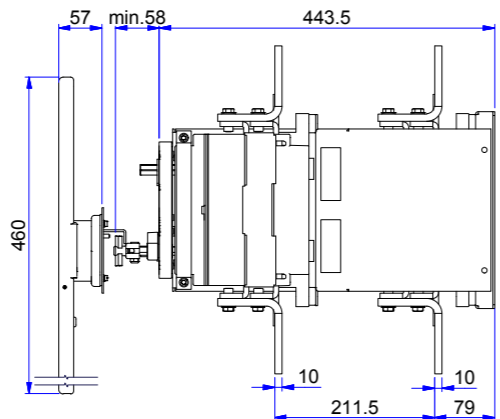
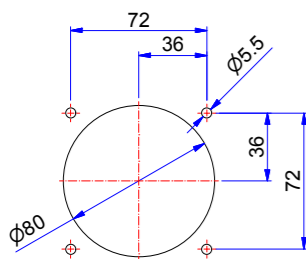

**CS6P OL 3150 A**

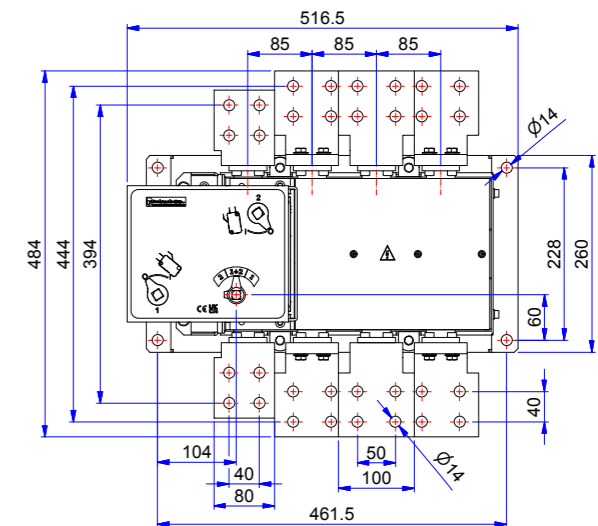

Foratura portella \_Door drilling

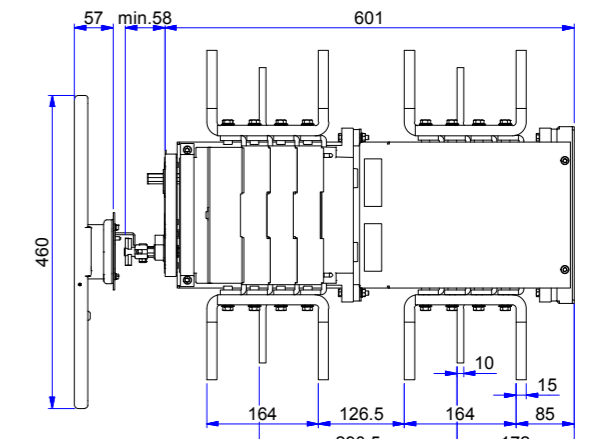
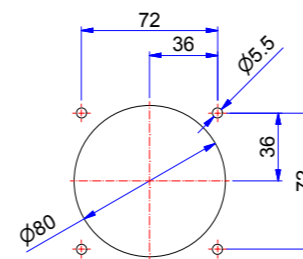

**Commutatori orizzontali  
con fusibili**  
**\_Horizontal change-over  
switches with fuses**



**CO1F**



**CO2F**



**CO3F**

**CO4F**

**CO5F**

Tipo _type	Corrente nomi- nale _rated cur- rent	POLI _POLES	Senza maniglia _without handle			Maniglia blocco porta _door interlock handle			
			NFC	DIN	BS	NFC	DIN	BS	
CODICE _CODES									
32 A	3	3	110203SM	110403SM	110603SM	110203	110403	110603	
			110303SM	110503SM	110703SM	110303	110503	110703	
	4	3	110213SM	110413SM	110613SM	110213	110413	110613	
			110313SM	110513SM	110713SM	110313	110513	110713	
	63A	3	3	110223SM	110423SM	110623SM	110223	110423	110623
				110323SM	110523SM	110723SM	110323	110523	110723
80A	3	3	110233SM	110433SM	110633SM	110233	110433	110633	
			110333SM	110533SM	110733SM	110333	110533	110733	
100A	3	3	110243SM	110443SM	110643SM	110243	110443	110643	
			110343SM	110543SM	110743SM	110343	110543	110743	
100A	4	3	120213SM	120413SM	120603SM	120213	120413	120603	
			120313SM	120513SM	120703SM	120313	120513	120703	
125A	3	3	120223SM	120423SM	120613SM	120223	120423	120613	
			120323SM	120523SM	120713SM	120323	120523	120713	
160A	3	3	120433SM	120623SM		120433	120623		
			120533SM	120723SM		120533	120723		
200A	3	3	130413SM	130613SM		130413	130613		
			130513SM	130713SM		130513	130713		
250A	3	3	130423SM	130623SM		130423	130623		
			130523SM	130723SM		130523	130723		
315A	3	3	140223SM	140423SM		140223	140423		
			140323SM	140523SM		140323	140523		
400A	3	3	140233SM	140433SM		140233	140433		
			140333SM	140533SM		140333	140533		
630A	3	3	150203SM	150403SM		150203	150403		
			150303SM	150503SM		150303	150503		
800A	3	3		150413SM			150413		
				150513SM			150513		

Caratteristiche tecniche _Technical Features	Tipo _Type		CO1F					CO2F		
	In	A	32	45	63	80	100	100	125	160
Corrente nominale _Rated current	Ui	V	1500	1500	1500	1500	1500	1500	1500	1500
Tensione nominale d'isolamento _Rated insulation voltage	U imp	kV	8	8	8	8	8	12	12	12
Tensione nominale impulso _Shock resistance	Ith	A	32	45	63	80	100	100	125	160
Corrente nominale termica _Thermal current	Corrente nominale d' impiego _Rated operational current									
AC-21A	400V	A	32	45	63	80	100	100	125	160
	500V	A	32	45	63	80	100	100	125	160
	690V	A	32	45	63	80	100	100	125	160
AC-22A	400V	A	32	45	63	80	80	100	125	160
	500V	A	32	45	63	80	80	100	125	160
AC-23A	400V	A	32	45	63	80	80	100	125	160
	500V	A	25	32	45	63	63	80	100	125
	690V	A	20	25	32	45	45	63	80	100
DC-21A	48V	A	32	50	63	80	100	100	125	160
	220V	A	32	50	63	80	100	100	125	160
	420V	A	32	50	63	80	100	100	125	160
DC-22A	560V	A	-	-	-	-	-	100	125	160
	48V	A	32	50	63	80	80	100	125	160
	220V	A	32	50	63	80	80	100	125	160
DC-23A	420V	A	32	50	63	80	80	100	125	160
	560V	A	-	-	-	-	-	100	125	160
	48V	A	32	50	50	63	80	100	125	160
Potenza nominale d'impiego _Rated operational power	400V AC23	kW	17	23	33	42	42	52	65	85
	Corrente di corto circuito condizionata da fusibile _Rated fuse short-circuit current									
	Tipo fusibile _Backup fuse	A	32	45	63	80	80	100	125	160
Valore efficace _R.M.S. value	kA	100	100	100	100	100	50	50	50	
Valore di picco _Peak value	kA	6	9	10	12	12	12	15	15	
Potere di chiusura nominale 420V c.a. cos 0,35 (0,45*) _ Rated making capacity at 420V AC cos 0,35 (0,45*)	A	320*	450*	630*	800*	800*	1000*	1250	1600	
Potere di interruzione nominale 420V cos 0,35 (0,45*) _Rated breaking capacity at 420V cos 0,35 (0,45*)	A	256*	360*	504*	640*	640*	800*	1000	1280	
Potere di chiusura, interruzione nominale c.c. (3) _Rated making and breaking capacity DC (3)	A	80	120	140	180	180	252	320	400	
Potenza condensatori a 400V Rated capacitor power at 400V	kVAR	15	20	30	40	45	45	50	70	
Durata meccanica \ Mechanical endurance	n	10000	10000	10000	10000	10000	8000	8000	8000	
Durata elettrica \ Electrical endurance	n	1500	1500	1500	1500	1500	1000	1000	1000	
Potenza dissipata per polo \ Power losses for pole*	W	0.3	0.6	1.2	2.0	3.1	2.1	3.3	5.5	
Dimensione cavo \ Cable section	mmq	25	25	25	25	35	70	70	70	
Dimensione barre \ Bars dimension	mm	12x3	12x3	12x3	12x3	16x3	16x4	16x4	16x4	
Peso netto _Net weight	3P	Kg	2,4	2,4	2,4	2,4	2,4	4	4	4
	4P		2,6	2,6	2,6	2,6	2,6	4,3	4,3	4,3

Due poli in serie \_Two poles in series

Escluso fusibile \_Fuse excluded



# SERIE\_SERIES CMA

Caratteristiche tecniche  
\_Technical Features

	Tipo _Type		CO3F		CO4F		CO5F	
Corrente nominale _Rated current	In	A	200	250	315	400	630	800
Tensione nominale d'isolamento _Rated insulation voltage	Ui	V	1500	1500	1500	1500	1500	1500
Tensione nominale impulso _Shock resistance	U imp	kV	12	12	12	12	12	12
Corrente nominale termica _Thermal current	Ith	A	200	250	315	400	630	800
Corrente nominale d'impiego _Rated operational current								
AC-21A	400V	A	200	250	315	400	630	800
	500V	A	200	250	315	400	630	800
	690V	A	200	250	315	400	630	800
AC-22A	400V	A	200	250	315	400	630	800
	500V	A	200	250	315	400	630	800
AC-23A	400V	A	200	250	315	400	630	800
	500V	A	160	200	250	315	500	630
DC-21A	48V	A	200	250	315	400	630	800
	220V	A	200	250	315	400	630	800
	420V	A	200	250	315	400	630	800
	560V	A	-	-	-	-	-	-
DC-22A	48V	A	200	250	315	400	630	800
	220V	A	200	250	315	400	630	800
	420V	A	200	250	315	400	630	800
	560V	A	-	-	-	-	-	-
DC-23A	48V	A	200	250	315	400	630	800
	220V	A	160	200	315	315	500	630
	420V	A	160	250	250	250	400	500
	560V	A	-	-	-	-	-	-
Potenza nominale d'impiego _Rated operational power	400V AC23	kW	105	130	165	210	330	420
Corrente di corto circuito condizionata da fusibile _Rated fuse short-circuit current								
Tipo fusibile _Backup fuse		A	200	250	315	400	630	800
Valore efficace _R.M.S. value		kA	50	50	50	50	50	50
Valore di picco _Peak value		kA	20	25	25	30	40	40
Potere di chiusura nominale 420V c.a. cos 0,35 (0,45*) _Rated making capacity at 420V AC cos 0,35 (0,45*)		A	2000	2500	3150	4000	6300	8000
Potere di interruzione nominale 420V cos 0,35 (0,45*) _Rated breaking capacity at 420V cos 0,35 (0,45*)		A	1600	2000	2520	3200	5040	6400
Potere di chiusura, interruzione nominale c.c. (3) _Rated making and breaking capacity DC (3)		A	500	640	800	1000	1600	2000
Potenza condensatori a 400V Rated capacitor power at 400V		kVAR	90	110	140	180	300	370
Durata meccanica \ Mechanical endurance		n	7000	7000	7000	7000	4000	4000
Durata elettrica \ Electrical endurance		n	1000	1000	1000	1000	1000	1000
Potenza dissipata per polo \ Power losses for pole*		W	11.7	17.5	12.9	20.8	52.9	85.3
Dimensione cavo \ Cable section		mmq	120	120	240	240	2x185	2x185
Dimensione barre \ Bars dimension		mm	25x4	25x4	32x5	32x5	2x40x6	2x40x6
Peso netto _Net weight	3P	Kg	9,5	9,5	16,2	16,2	29,2	29,2
	4P		9,9	9,9	16,8	16,8	30,8	30,8

Due poli in serie \_Two poles in series

Escluso fusibile \_Fuse excluded

## CO1F 32 - 100 A

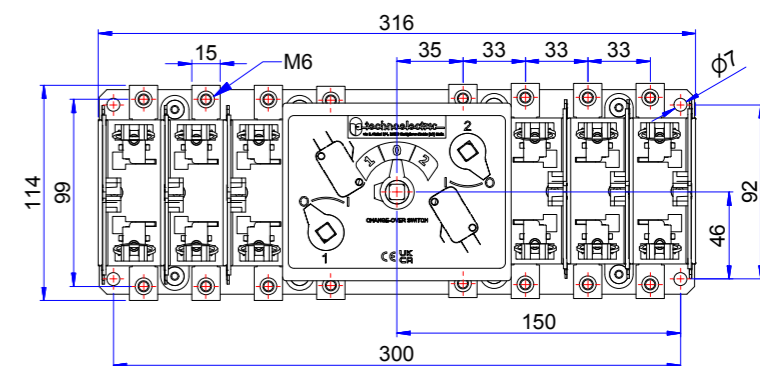

Foratura portella \_Door drilling

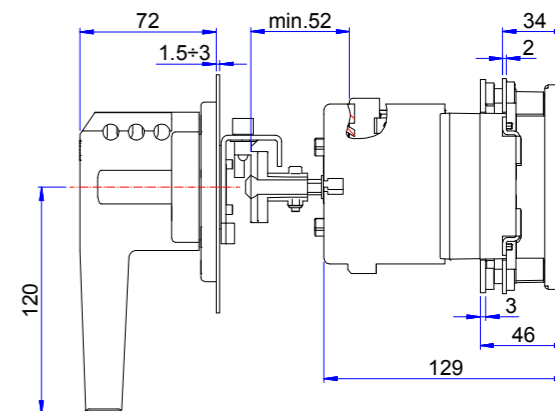
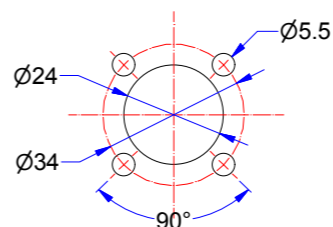

## CO2F 100 - 160 A

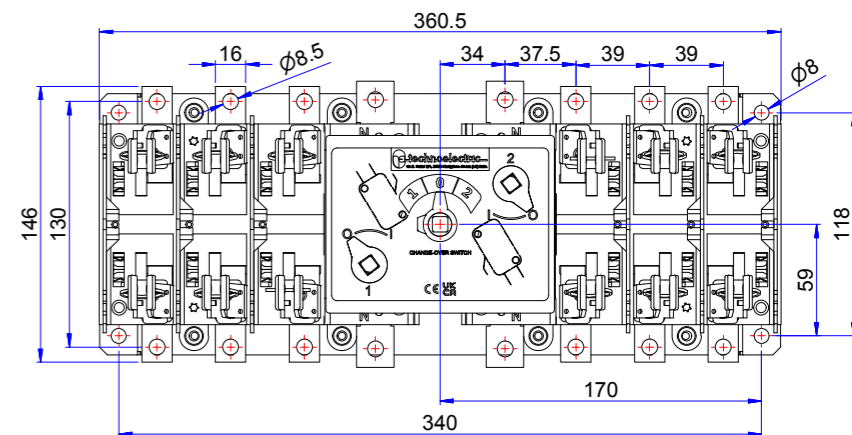

Foratura portella \_Door drilling

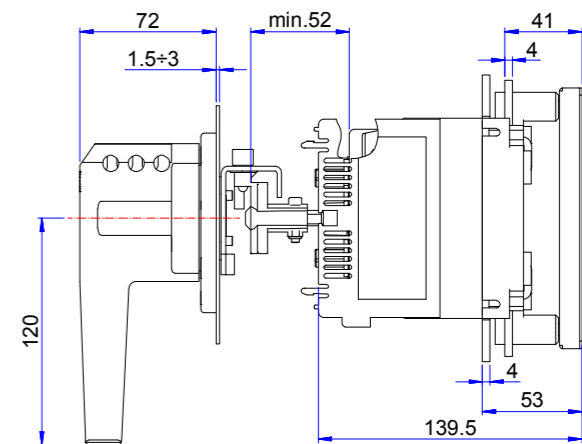
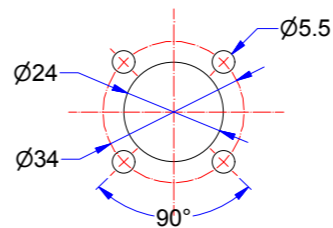

CO3F 200 - 250 A

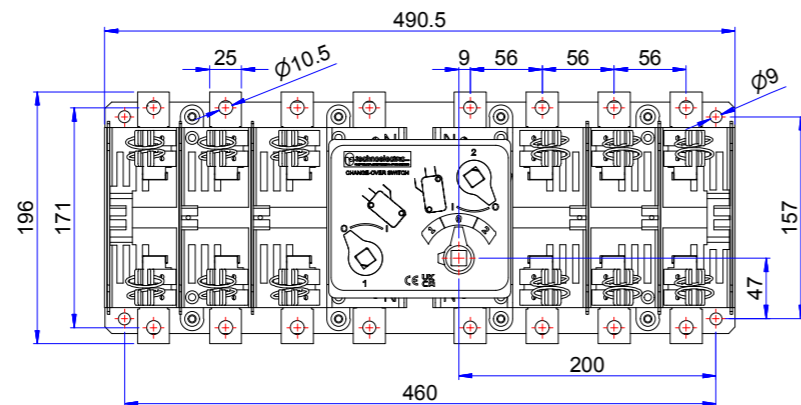

Foratura portella \_Door drilling

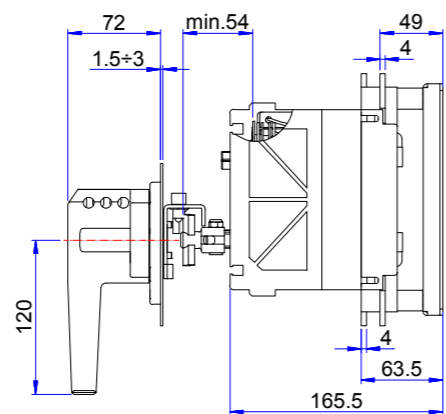
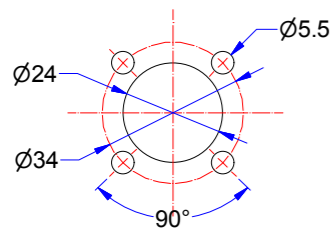

CO5F 630 - 800 A

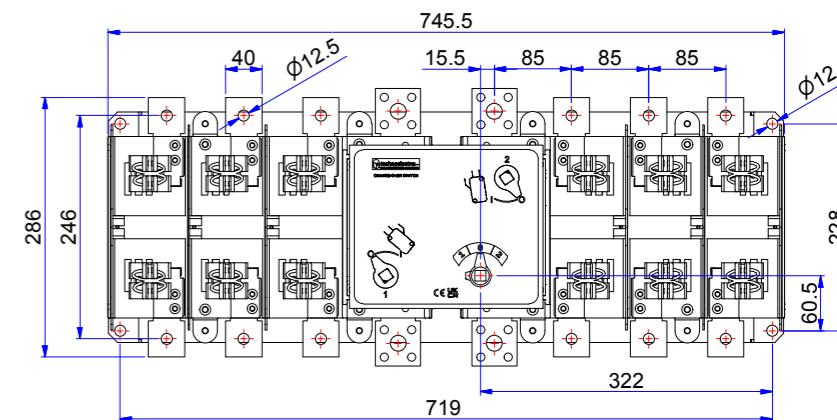

Foratura portella \_Door drilling

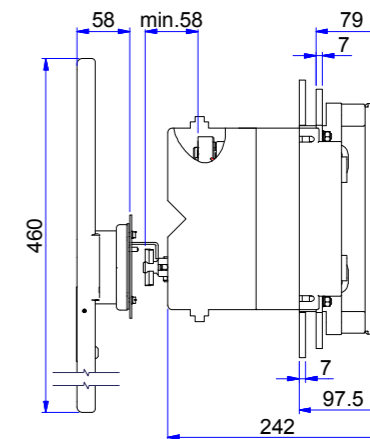
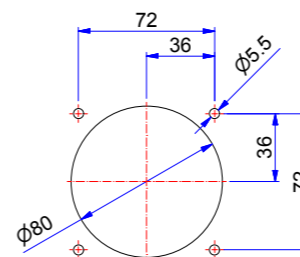

CO4F 315 - 400 A

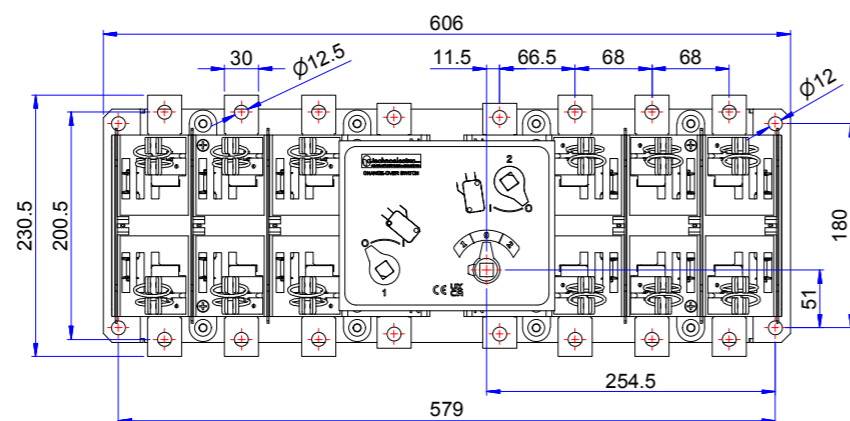

Foratura portella \_Door drilling

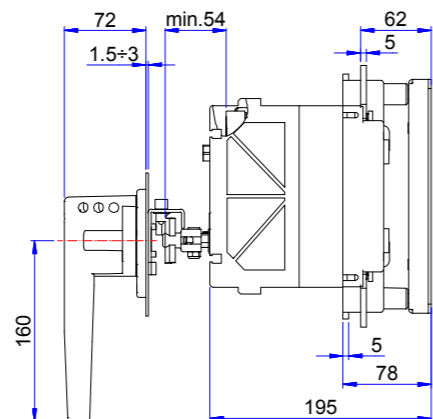
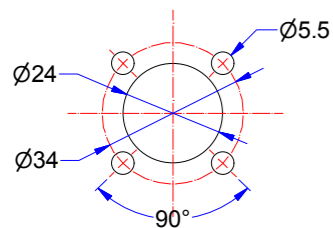

# COMMUTATORE GT

## GENERALITÀ

Serie di commutatori ad azionamento manuale che permettono l'apertura e la commutazione di due circuiti elettrici in bassa tensione. Sono realizzati interbloccando due normali interruttori sezionatori della serie GT.

## CARATTERISTICHE GENERALI

3 Posizioni I-O-II  
 Visibilità diretta, mediante finestrelle, dei contatti fissi e mobili  
 Manovre a scatto rapido indipendente  
 Doppia interruzione per ogni polo  
 Elevata durata meccanica ed elettrica  
 Adatti per utilizzo in climi tropicali  
 Comando di tipo rotativo frontale a mezzo di:  
 Maniglia esterna a doppio isolamento con dispositivo bloccoporta nelle posizioni I e II

## CONDIZIONI NORMALI DI SERVIZIO, MONTAGGIO E TRASPORTO

temperatura ambiente di immagazzinamento e trasporto - 25°C + 55°C  
 temperatura ambiente di funzionamento - 20°C + 40°C  
 in caso di temperatura ambiente (t<sub>a</sub>) superiore, applicare la seguente formula di declassamento:

$$I_{The} = k I_{Th} \text{ dove } K = 1 - \frac{t_a - 40}{100}$$

- umidità relativa max 95%
- frequenza nominale 50 - 60 Hz
- altitudine max 2000 m s.l.m.
- grado di inquinamento 3 secondo IEC 60947-1
- tipo di servizio (secondo IEC 60947-1):
  - servizio 8 ore
  - servizio ininterrotto
  - servizio intermittente 60% classe 30
  - servizio temporaneo
  - servizio periodico

Per condizioni di impiego diverse consultare il costruttore.

## GT CHANGE-OVER SWITCHES

### GENERALITIES

Change-over switches manually operated suitable for breaking and permutating two low voltage electrical circuits. They are made by two standard switches of GT series mechanically interlocked.

### GENERAL CHARACTERISTICS

3 Positions I-O-II  
 Visibility of fixed and moving contacts by means of windows  
 Independent fast action operation  
 Double break contacts  
 High electrical and mechanical endurance  
 Resistant to damp heat  
 Rotary front operation by means of:  
 External double insulated handle with door-interlock in I and II position

### NORMAL SERVICE, MOUNTING AND TRANSPORT CONDITIONS

storage and transport ambient temperature - 25°C + 55°C  
 working ambient temperature - 20°C + 40°C  
 in case of higher ambient temperature (t<sub>a</sub>) consider the following derating formula:

$$I_{The} = k I_{Th} \text{ dove } K = 1 - \frac{t_a - 40}{100}$$

- relative humidity max 95%
- rated frequency 50 - 60 Hz
- altitude max 2000 m a.s.l.
- pollution degree 3 according IEC 60947-1
- duty (IEC 60947-1):
  - eight-hour duty
  - uninterrupted duty
  - intermittent duty 60% class 30
  - temporary duty
  - periodic duty

For other operating conditions please contact the manufacturer.



Tipo _type	Corrente nominale _rated current	POLI _POLES	CODICE _CODES
GT6	3150A	3P	GT60038
		4P	GT60138
	4000A	3P	GT60048
		4P	GT60148

Caratteristiche tecniche _Technical Features	Tipo _Type		GT 3150	GT 4000
Corrente nominale _Rated current	I <sub>n</sub>	A	3150A	4000A
Tensione nominale d'isolamento _Rated insulation voltage	U <sub>i</sub>	V	1500	1500
Corrente nominale termica _Thermal current	I <sub>th</sub>	A	3150	4000
<b>Corrente nominale d' impiego _Rated operational current</b>				
AC-21A	420V	A	3150	4000
	500V	A	3150	4000
	690V	A	-	-
AC-22A	420V	A	-	-
	500V	A	-	-
	690V	A	-	-
AC-23A	420V	A	-	-
	500V	A	-	-
	690V	A	-	-
Corrente di breve durata _Short-circuit withstand current	1 sec	kA	50	50
Potere di chiusura in corto circuito _Short-circuit making capacity		kA	105	105
<b>Corrente di corto circuito condizionata da fusibile _Rated fuse short-circuit current</b>				
Tipo fusibile _Backup fuse		A	-	-
Valore efficace _R.M.S. value		kA	-	-
Valore di picco _Peak value		kA	-	-
Durata meccanica _Mechanical endurance		n.	2500	2500
Durata elettrica _Electrical endurance		n.	500	500
Potenza dissipata per polo _Power dissipation per pole		W	170	272
Potenza condensatori a 400V _Rated capacitor power at 400V	400 V	kVAR	1250	1600
Peso netto _Net weight	3P	Kg	180	180
	4P		220	220

GT 4000A 3P

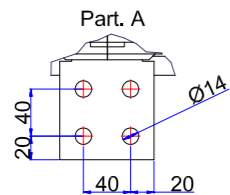
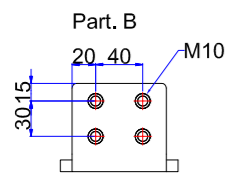
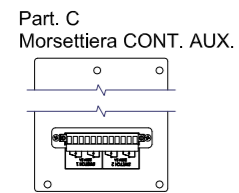
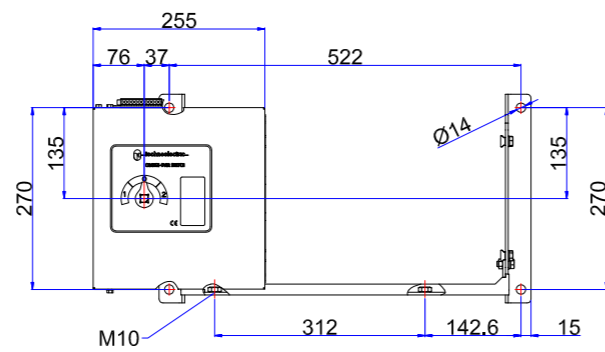
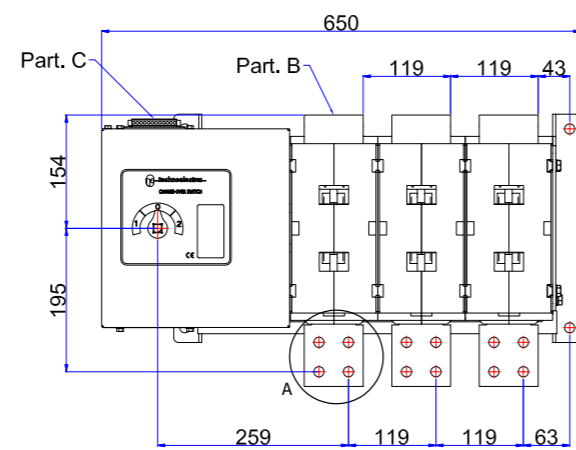
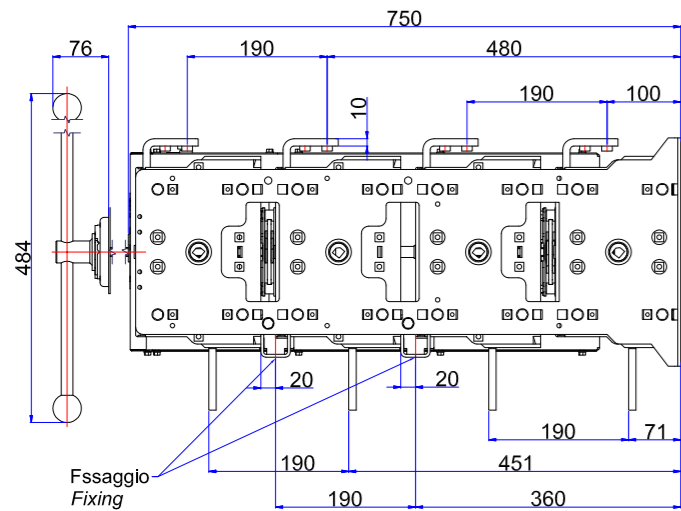

GT 4000A 4P

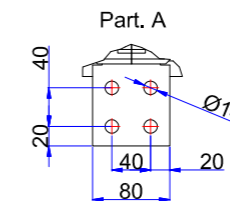
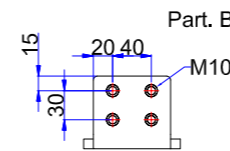
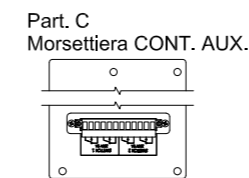
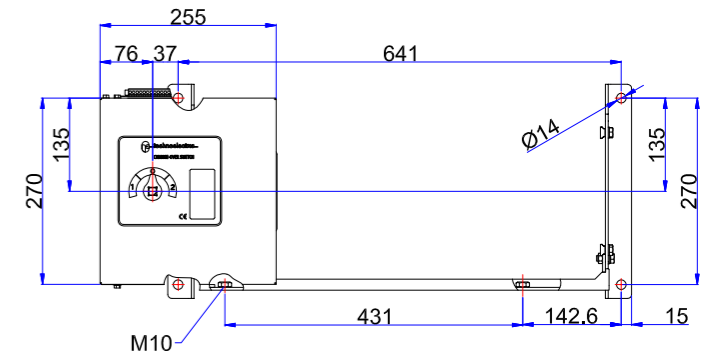
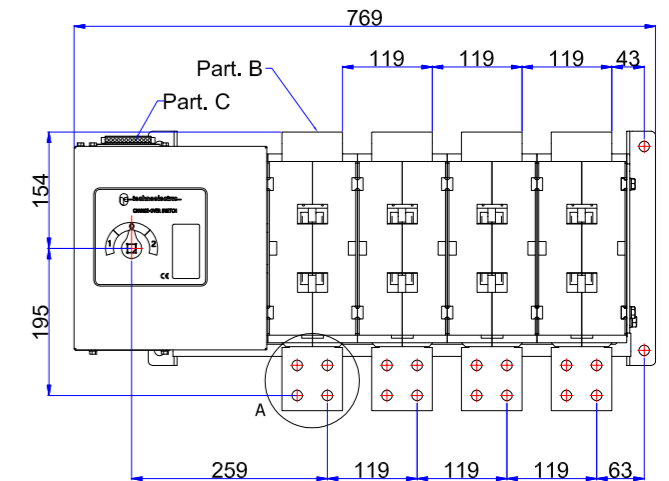
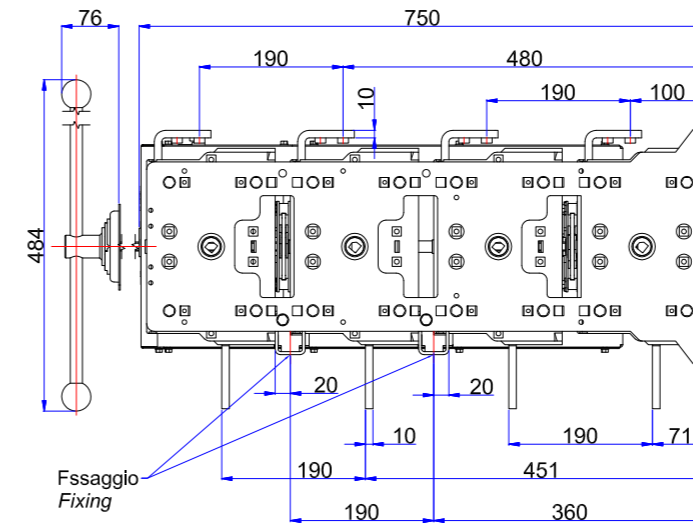



**MANIGLIA BLOCCO PORTA\_Door interlock handles**

Tipo_type	CO - CS - BYP 1   2   3	CO - CS - BYP 4	CO - CS - BYP 5 35 kA	CO - CS 5 50kA   CO - CS 6	CO - CS 5 50kA   CO - CS 6
Codice_code	18582	18583	18584	18838	18839

**18582**

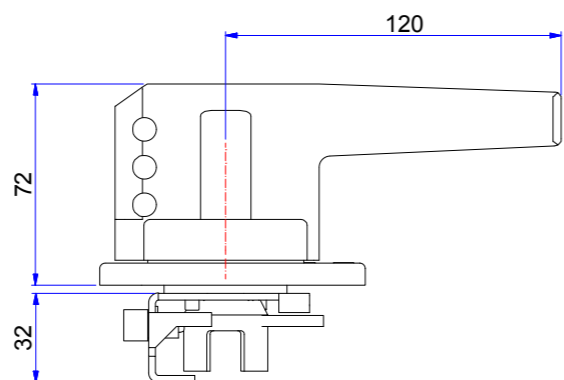

Foratura portella \_Door drilling

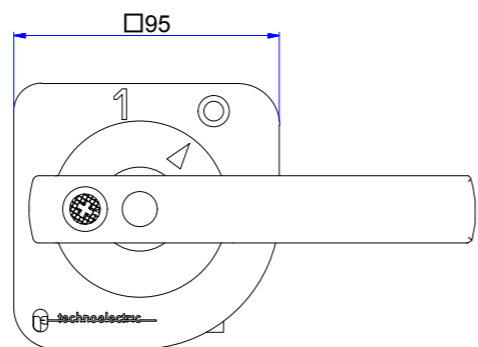
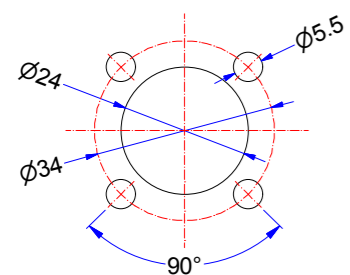

**18583**

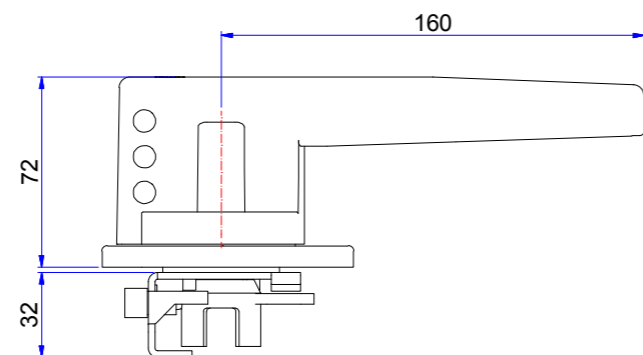

Foratura portella \_Door drilling

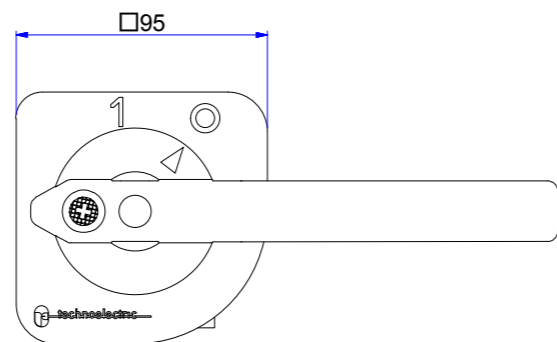
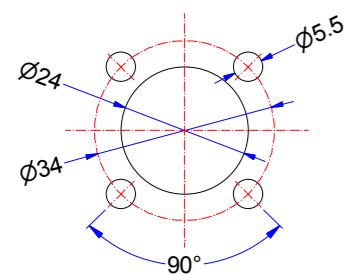

**18584**

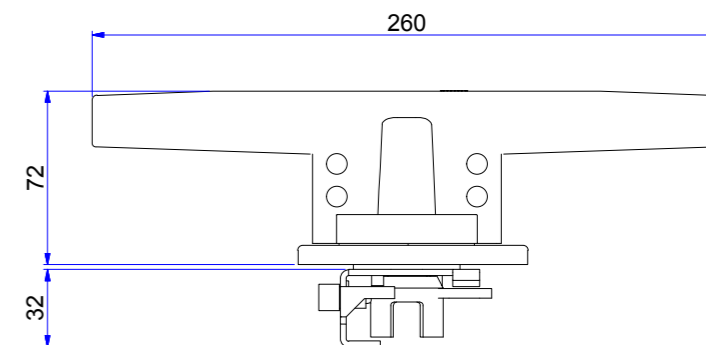

Foratura portella \_Door drilling

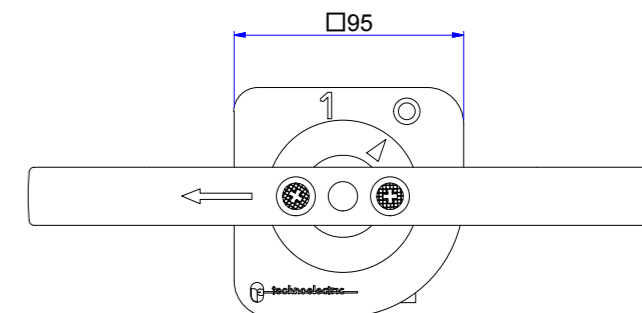
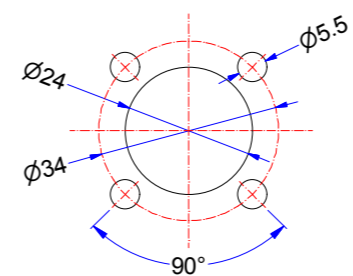

**18838**

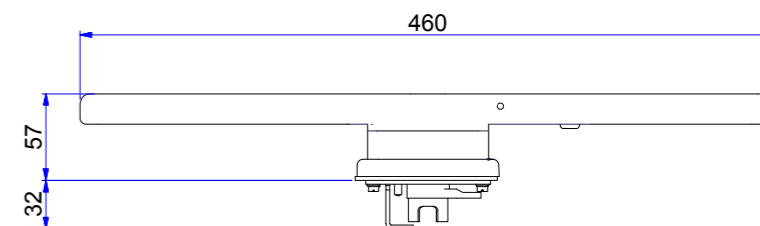

Foratura portella \_Door drilling

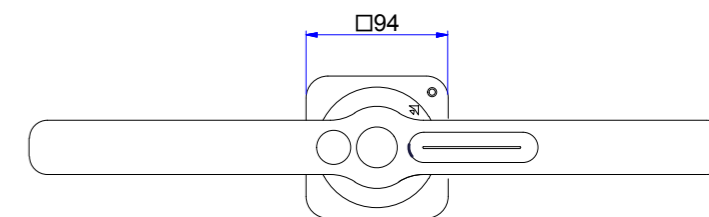
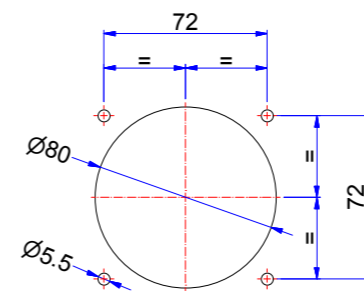

**18839**

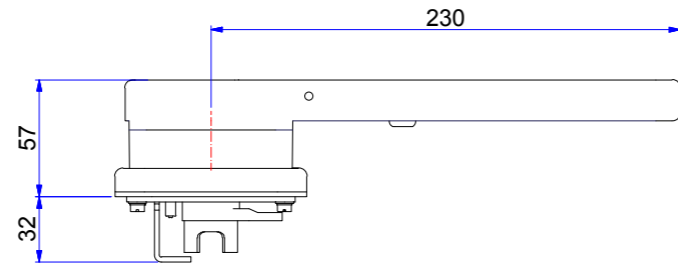

Foratura portella \_Door drilling

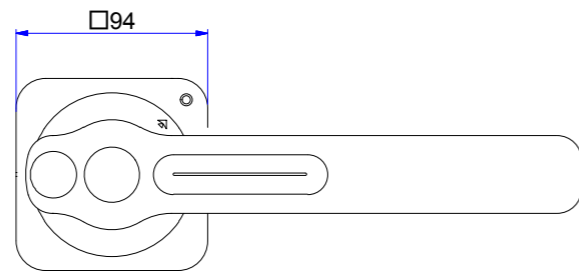
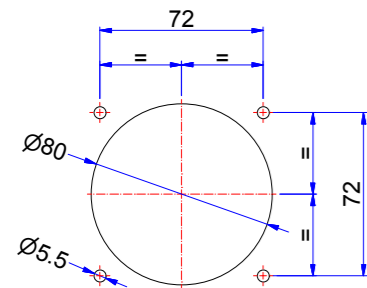

**MANIGLIA DIRETTA CON SCHERMI\_direct handle with covers**

Tipo_type	CO1P	CO2P	CO3P	CO4P	CO5P	CO6P
Codice_code	18588	18589	18590	18591	18853	18853

Fornita completa di due schermi copricontatti principali per interruttori di tipo P.

Versione lucchettabile fornibile a richiesta

\_With two main contact shields covers. Padlockable version on request.

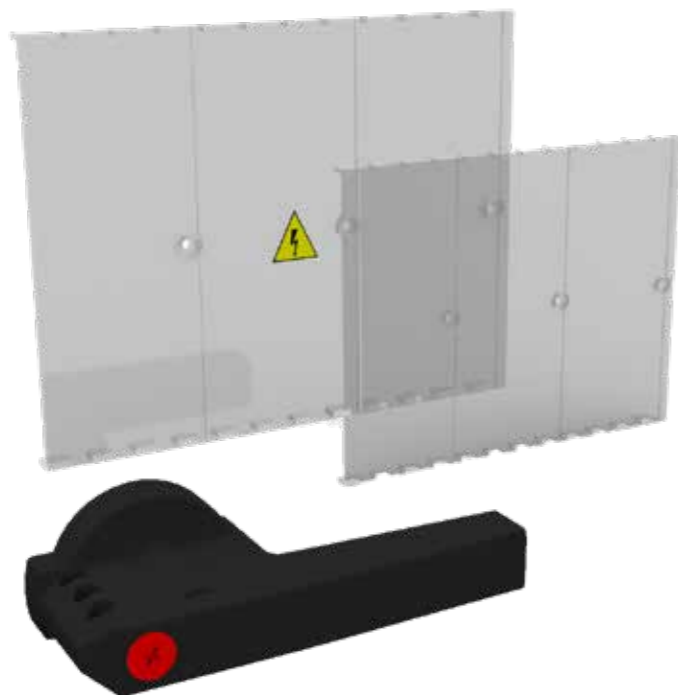

**MANIGLIA DIRETTA SENZA SCHERMI\_direct handle without covers**

Tipo_type	CS1-CS2	CS3	CS4	CS5 35kA	CS5 50kA - CS6
Codice_code	18187	18083	18084	18188	18189

**18187**

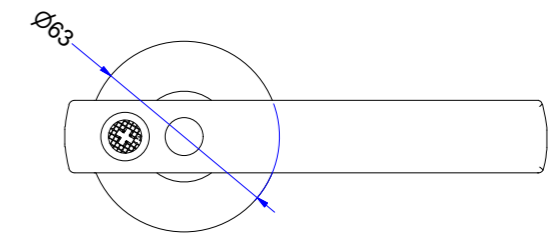
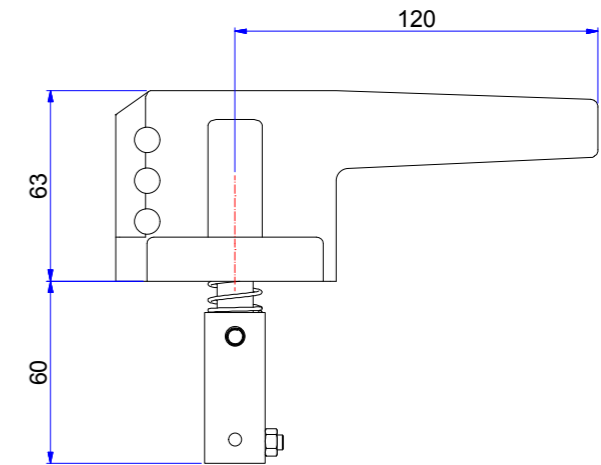

**18083**

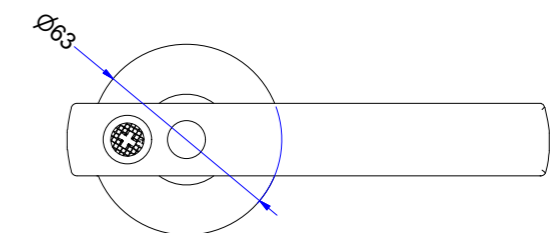
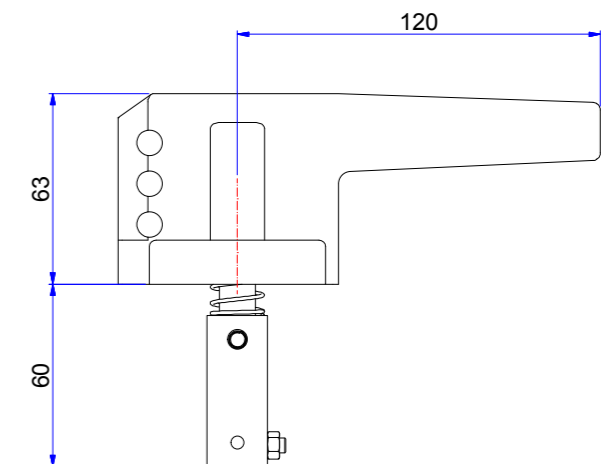

18084

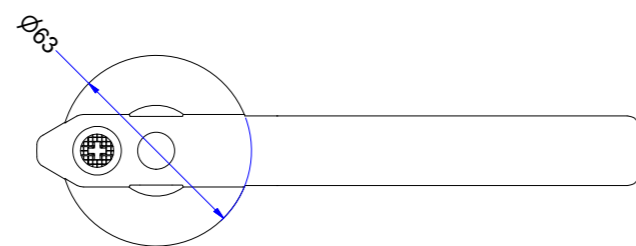
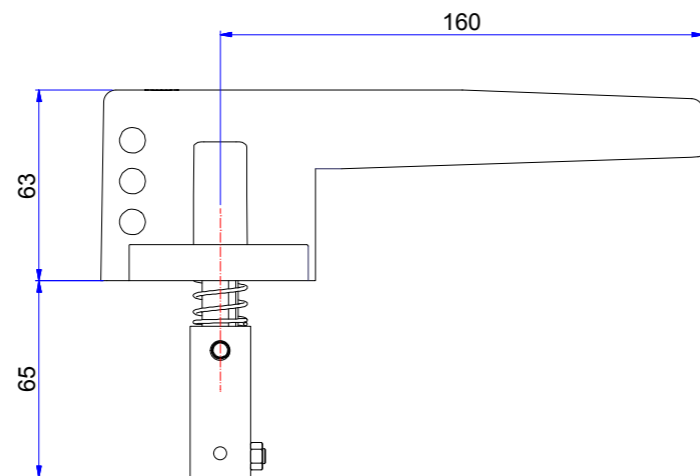

18189

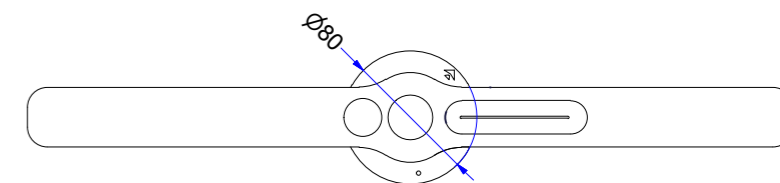
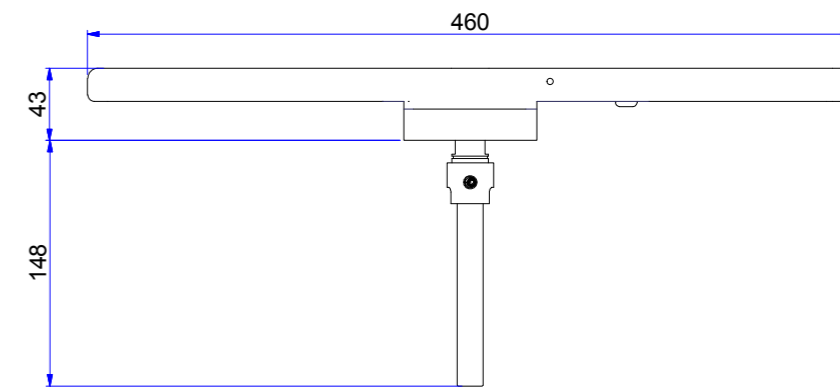

**MANIGLIA BLOCCO PORTA CON BLOCCO CHIAVE IN POSIZIONE 0**  
**\_door interlock handle with key lock 0 position**

Tipo_type	CO - CS - CC - BYP 1   2   3	CO - CS - CC - BYP 4	CO - CS - C BYP5 35 kA
Codice_code	18500	18501	18502

18188

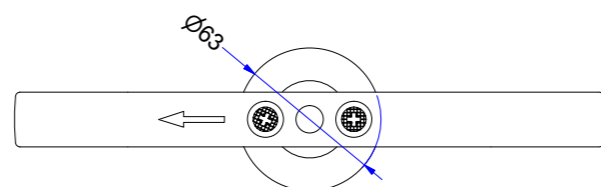
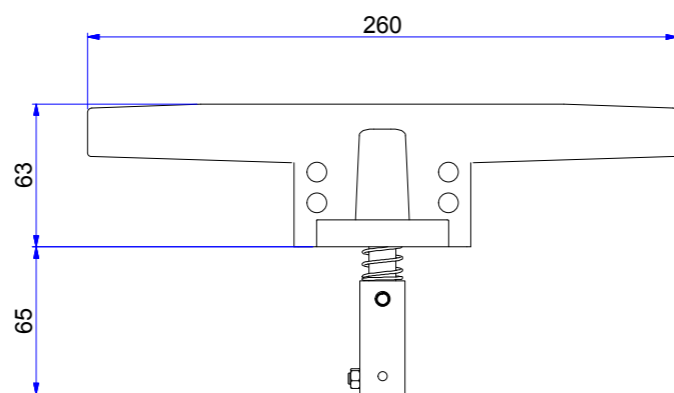

18500

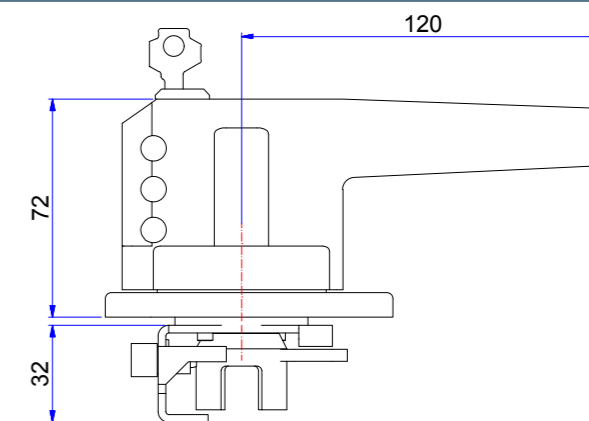

Foratura portella \_Door drilling

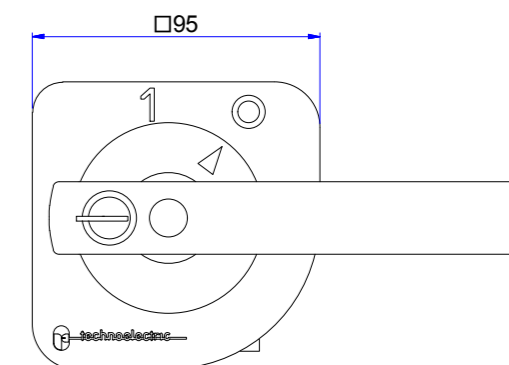
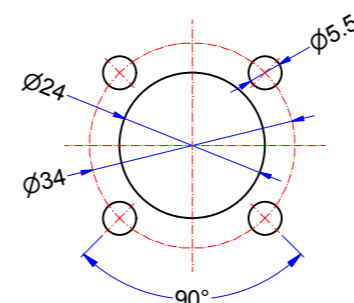

18501



Foratura portella \_Door drilling

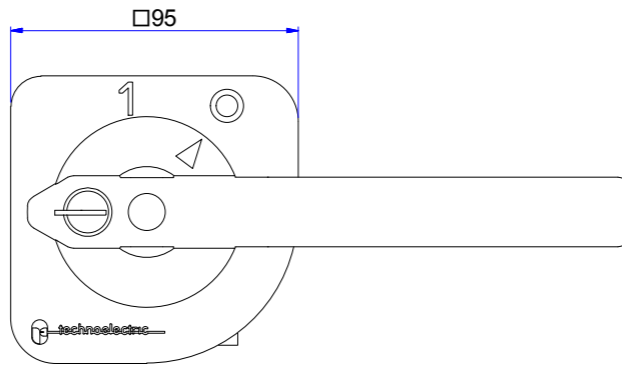
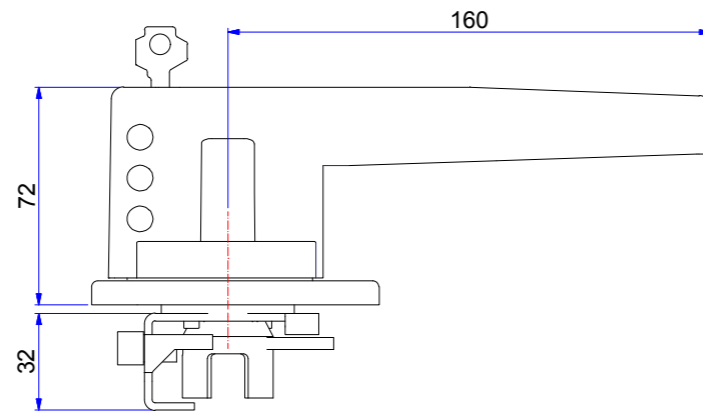
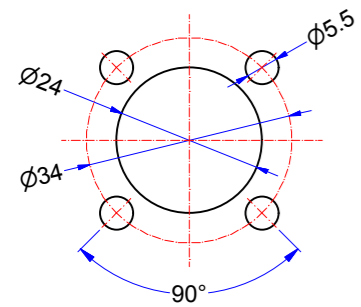

18502



Foratura portella \_Door drilling

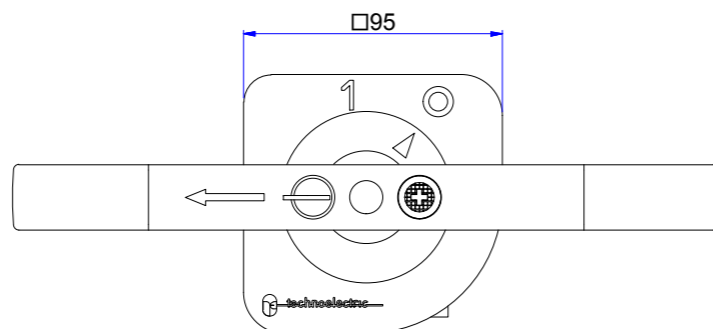
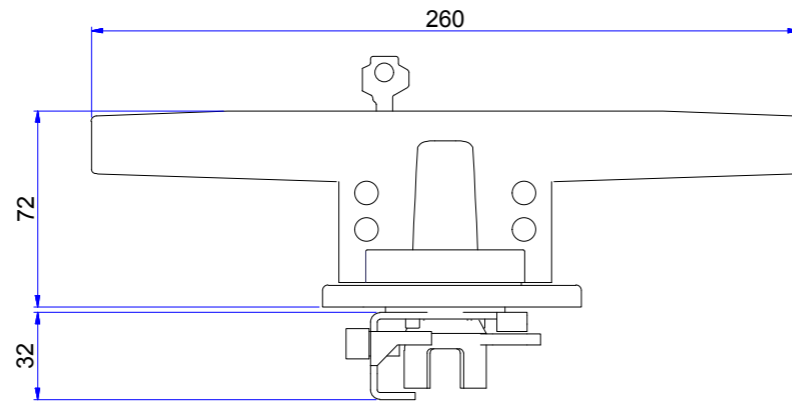
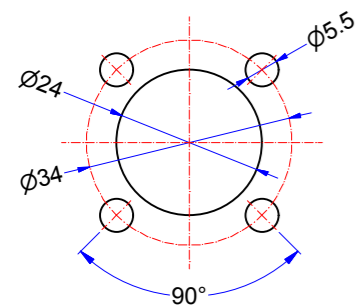

PROLUNGA ALBERO COMANDO  
\_extension shaft



100 MM

Tipo_type	CO - CS - BYP 1   2	CO - CS - BYP 3   4   5 CO - CS 6
Codice_code	18571	18573

200 MM

Tipo_type	CO - CS - BYP 1   2	CO - CS - BYP 3   4   5 CO - CS 6
Codice_code	18574	18576

ALBERO COMANDO 300 MM  
\_300mm Shaft



Tipo_type	CO - CS - BYP 1   2	CO - CS - BYP 3   4   5 CO - CS 6
Codice_code	18575	18578

CONTATTI AUSILIARI IN SCAMBIO 1NA+1NC  
\_auxiliary changeover contacts 1NO+1NC

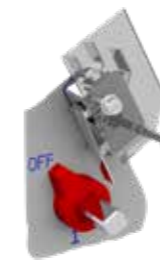

18566



18560

Tipo_type	CO - CS - BYP 1   2	CO - CS - BYP 3   4   5 CO - CS 6
Codice_code	18566	18560



**CONTATTI AUSILIARI IN SCAMBIO 2NA+2NC**  
**\_auxiliary changeover contacts 2NO+2NC**



18568

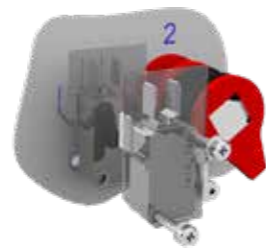

18567

Tipo_type	CO - CS - BYP 1   2	CO - CS - BYP 3   4   5 CO - CS 6
Codice_code	18568	18567

**CALOTTA PROTEZIONE TERMINALI SUPERIORI**  
**\_upper terminal cover**

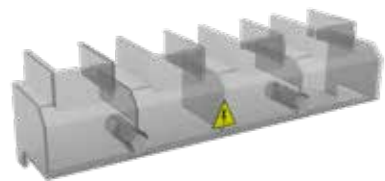

Tipo_type	CO1P	CO2P	CO3P	CO4P	CO5P	CO5P 1600 A
Codice_code	18050	18052	18350	18054	18056	18058

**CALOTTA PROTEZIONE TERMINALI INFERIORI**  
**\_lower terminal cover**



Tipo_type	CO1P	CO2P	CO3P	CO4P	CO5P	CO5P 1600 A
Codice_code	18051	18053	18351	18055	18057	18059

**CONNESSIONI A PONTE**  
**\_Connecting bridges**

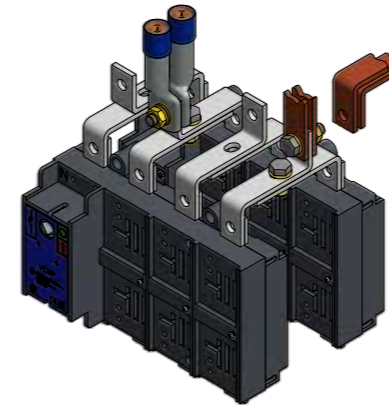

**COLLEGAMENTO CAVO\SBARRA \_connection cable\bar**

Tipo_type	CS1 32-160A		CS2 160-315A		CS3 315-500A		CS4 630-800A	
Poli_poles	3P	4P	3P	4P	3P	4P	3P	4P
Codice_code	18411	18410	18408	18409	18419	18412	18417	18418

**COLLEGAMENTO SBARRA \_connection bar**

Tipo_type	CS5 800-1250A	
Poli_poles	3P	4P
Codice_code	18424	18414

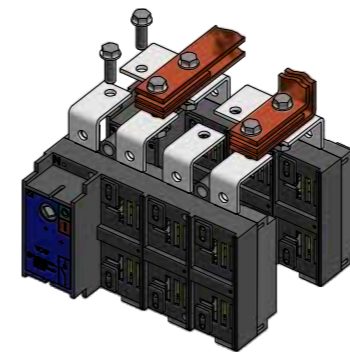

**COLLEGAMENTO CAVO \_connection cable**

Tipo_type	CS5 1600-2000A		CS5 1600-2000A
Poli_poles	3P	4P	4P FN
Codice_code	18438	18439	18440

**PIATTO PER TERMINALI SEZIONATORI**  
**\_terminal plate for switches**



Tipo_type Piatto_plate	CO - CS 5 4 MM	CO - CS 5 6 MM
Codice_code	18138	18139

La confezione contiene 1 piatto per terminali  
 \_Each box contain a terminal plate

**MANIGLIA BLOCCO PORTA\_Door interlock handles**

Tipo_type	CO 1F	CO 2F	CO 3F	CO 4F	CO 5F
Codice_code	18582	18582	18582	18583	18584

**18582**

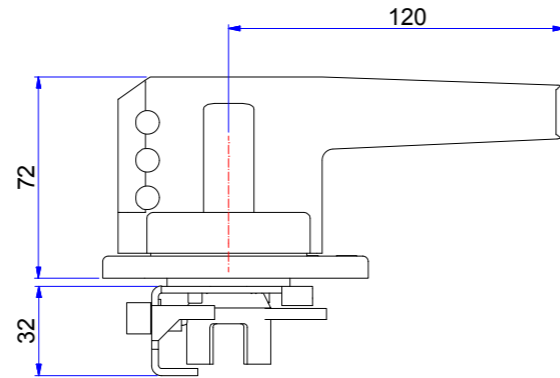

Foratura portella \_Door drilling

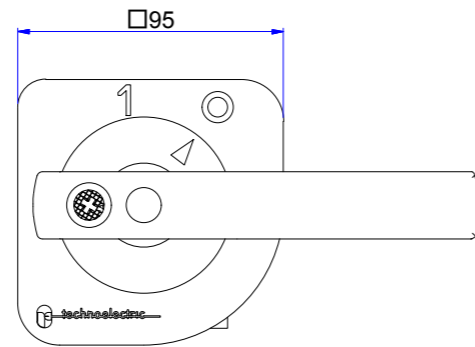
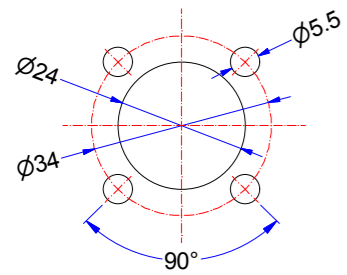

**18583**

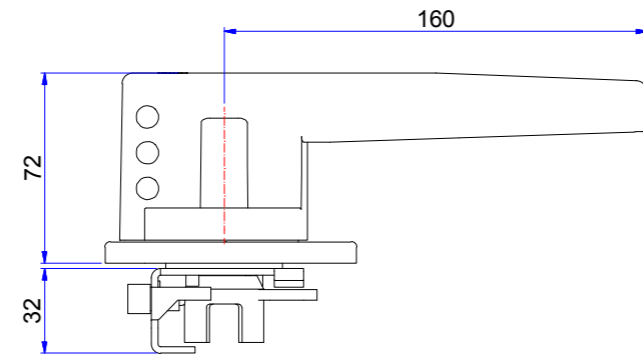

Foratura portella \_Door drilling

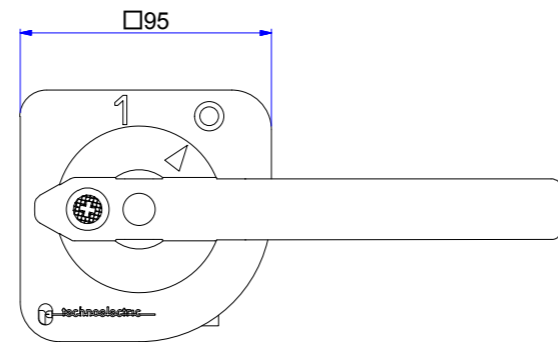
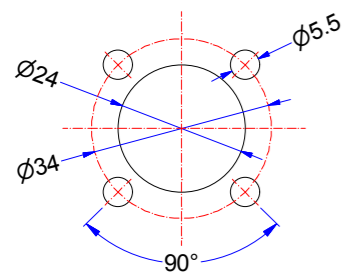

**18584**

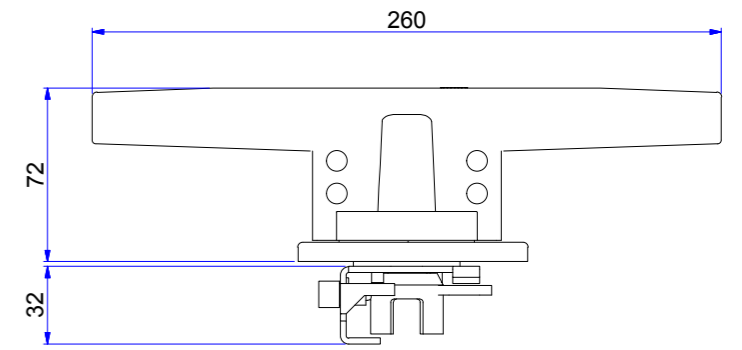

Foratura portella \_Door drilling

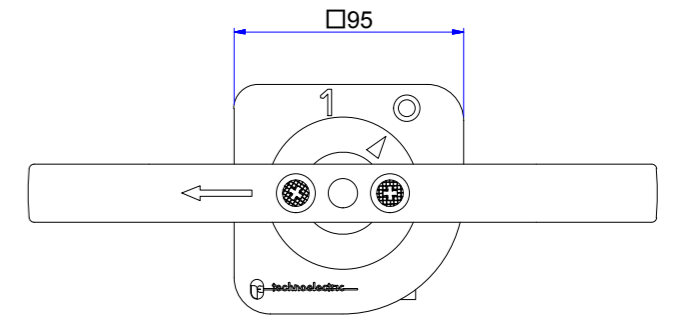
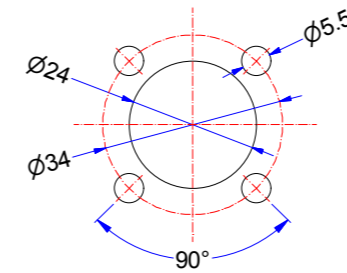

**MANIGLIA BLOCCO PORTA CON BLOCCO CHIAVE  
\_Door interlock handles with key lock**

Tipo_type	CO 1F	CO 2F	CO 3F	CO 4F	CO 5F
Codice_code	18500	18500	18500	18501	18502

**18500**

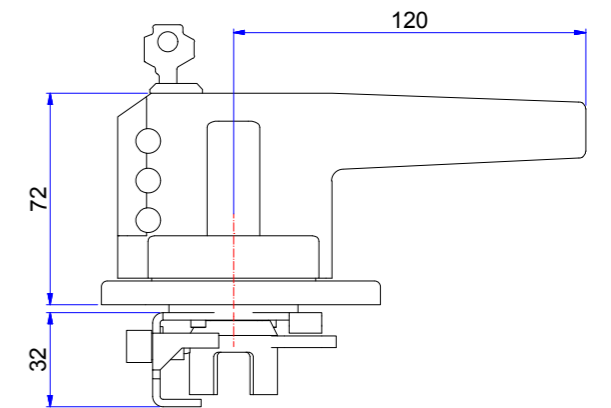

Foratura portella \_Door drilling

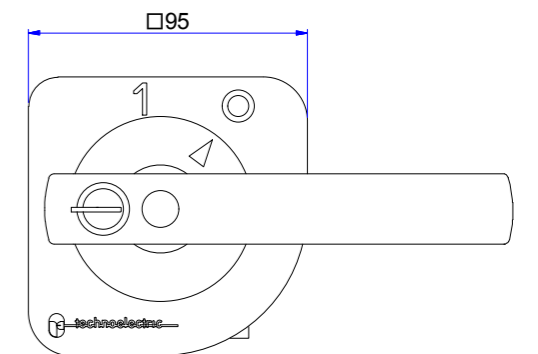
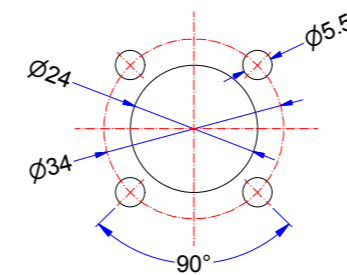

18501

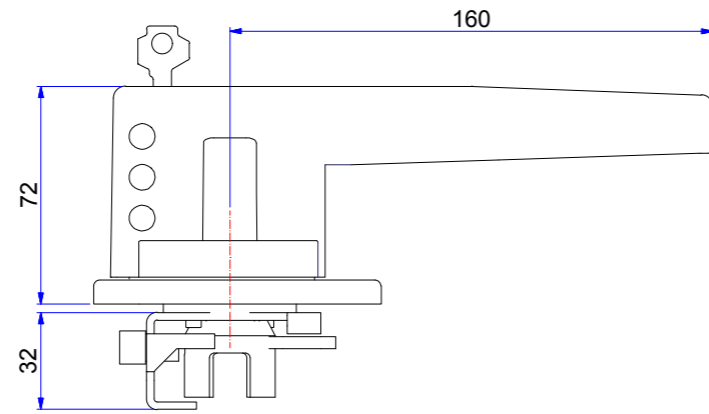

Foratura portella \_Door drilling

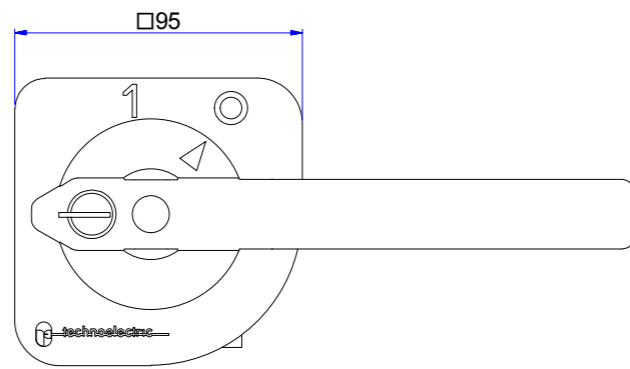
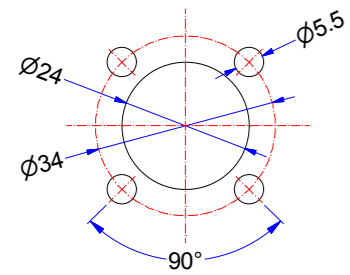

MANIGLIA DIRETTA  
\_direct handle



Tipo_type	CO 1F	CO 2F	CO 3F	CO 4F	CO 5F
Codice_code	18594	18595	18597	18598	18599

SCHERMO PROTEZIONE FUSIBILI  
\_fuse cover



Tipo_type	CO 1F	CO 2F	CO 3F	CO 4F	CO 5F
Codice_code	18660	18661	18663	18664	18665

18502

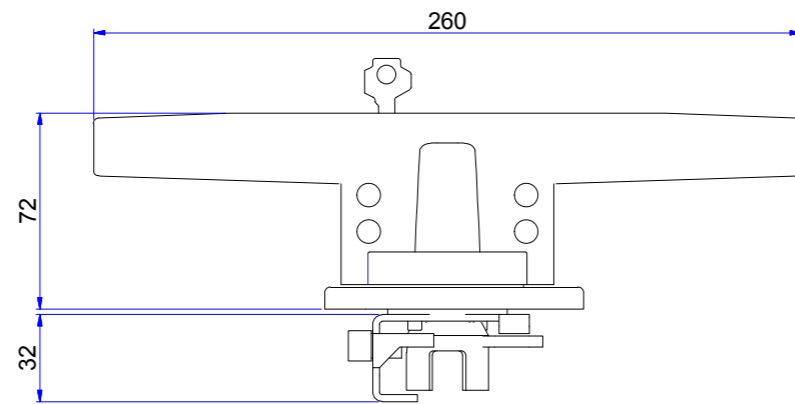

Foratura portella \_Door drilling

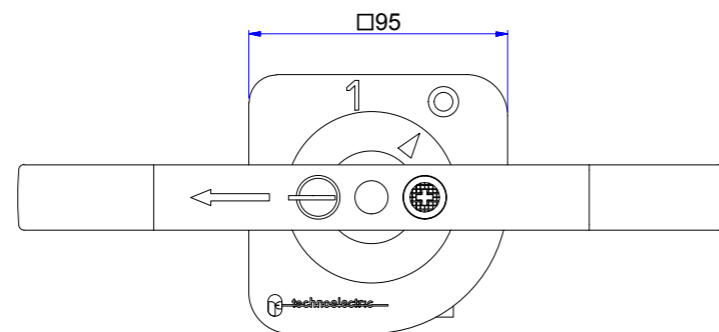
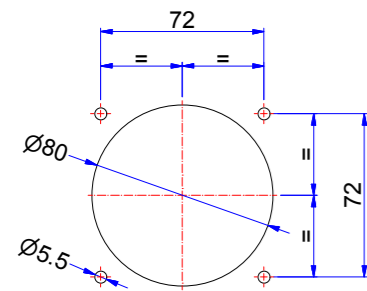

PROLUNGA ALBERO COMANDO  
\_extension shaft



100 MM

Tipo_type	COF 1   2	COF 3   4   5
Codice_code	18571	18573

200 MM

Tipo_type	COF 1   2	COF 3   4   5
Codice_code	18574	18576

ALBERO COMANDO 300 MM  
\_300mm Shaft



Tipo_type	COF 1   2	COF 3   4   5
Codice_code	18575	18578

# COMMUTATORI MOTORIZZATI

## \_MOTORIZED CHANGE-OVER SWITCHES

**CMO 160 ÷ 4000 A**





## **GENERALITÀ**

Le apparecchiature di commutazione con comando motorizzato, tripolari e tetrapolari consentono manovre a distanza di commutazione/interruzione/sezionamento sottocarico di linee di potenza in sistemi di bassa tensione.

## **GAMMA**

La gamma di commutatori motorizzati è costituita da 15 taglie con portate amperometriche da 160A a 4000A, 3 e 4 poli, disponibile la serie CS (versione sovrapposta) e la serie CO (versione orizzontale).

La serie CS è costituita da 4 famiglie: MSX1, MSX, MSY, MS differenziate tra loro principalmente per le diverse tensioni di alimentazione e per la visualizzazione della posizione del commutatore.

La serie CO è realizzata nella sola versione MS.

## **CARATTERISTICHE GENERALI**

I commutatori motorizzati sono realizzati impiegando due interruttori di manovra-sezionatori della serie Visualcompact e della serie Globe Technics interbloccati meccanicamente tra di loro.

Commutazione automatica sotto carico (ac-22, ac-23) da e per qualsiasi delle posizioni “1”, “0”, “2” sia elettrica che manuale (commutazione d'emergenza) funzione deviatore con passaggio diretto da “1” a “2” e viceversa Visualizzazione frontale delle posizioni “1”, “0”, “2” a mezzo display (per la versione ms) indice meccanico

Sicurezza: blocco lucchettabile che interdice ogni manovra elettrica o manuale, blocco a chiave per la selezione della manovra elettrica o manuale (solo su serie ms-co)

Segnalazioni esterne delle posizioni “1”, “0”, “2” tramite contatto Pulito (non alimentato)

Tempi rapidi di manovra da “1” a “2” e viceversa

Collegamenti facili ed immediati a mezzo morsettiera ad aggancio rapido

Alimentazioni 12-24v cc, 110/220v ca, altre a richiesta

Dimensioni compatte

Scelta della logica funzionamento per mezzo di un micro-interruttore posto sulla scheda di comando facilmente accessibile per le seguenti logiche:

- A) impulso (min. 150ms)
- B) contattore (contatto mantenuto)

## **\_GENERALITIES**

The three and four pole change-over switches, with motorized operation, allow remote control of change-over/breaking/disconnection under load of power circuits in low voltage systems.

## **\_RANGE**

The range of motorized change-over switches is made by 15 sizes of switches of current rating from 160A to 4000A, 3 and 4 poles are available in the CS series with switch disconnectors laid one upon the other and in the “CO” series with switch disconnectors horizontally interlocked. The CS series is made by 4 families: MSX1, MSX, MSY, MS differentiated among them mainly by the supply voltage and by the display of the position of the change-over switch.

The horizontal CO series is made in the MS version only.

## **\_GENERAL CHARACTERISTICS**

The motorized change-over switches are made by means of two switch disconnectors of Visualcompact and Globe Technics series mechanically interlocked.

Automatic under-load change-over (ac-22, ac-23) from and to any of positions “1”, “0”, “2” both electrical and manual (emergency changeover), transfer function with direct transition from position “1” to position “2” and viceversa

Front display of positions “1”, “0”, “2” by digital display (for ms version) mechanical indicator

Safety: locking by padlock preventing any electrical or manual operation, key lock for the selection of electrical or manual operation (for ms series only)

External signalisation of positions “1”, “0” and “2” by a clean contact (no voltage supply)

Quick operating time from pos. “1” To “2” and back

Easy and fast electrical connections by means of terminal blocks of quick connection type

Power supply voltage 12-24v dc, 110/220v ac, others on request

Compact dimensions

Selection of operating logic by a micro switch on the pc board and easily accessible for the following logic:

- A) impulse (150ms min)
- B) contactor (maintained contact)

---

Commutatori sovrapposti serie MSX tipo CS 2-3-4-5 da 160A a 1250A, alimentazione 24V dc, visualizzazione a indice meccanico.

Commutatori sovrapposti serie MSX1 tipo CS 2-3-4 da 160A a 800A, alimentazione 12V dc, visualizzazione a indice meccanico.

Commutatori sovrapposti serie MSY tipo CS 2-3-4-5 da 160A a 1250A, alimentazione 220V ac, visualizzazione a indice meccanico.

Commutatori sovrapposti serie MS tipo CS 3-4-5-6 da 315A a 3150A e serie GT da 4000A, alimentazione multipla 24V dc, 110/220 ac, visualizzazione a mezzo display ed indice meccanico.

Commutatori orizzontali serie MS tipo CO 4-5-6 da 630A a 3150A, alimentazione multipla 24V dc, 110/220 ac, visualizzazione a mezzo display e indice meccanico.

## **ACCESSORI**

Connessioni a ponte per commutatori sovrapposti della serie CS2, CS3, CS4 e CS5.

Esecuzioni speciali e tensioni di alimentazione speciali a richiesta.

Maniglia per la manovra manuale di emergenza sempre inclusa

---

Two layers change-over switches MSX series types CS 2-3-4-5 from 160A to 1250A, power supply 24V DC, display by mechanical indicator.

Two layers change-over switches MSX1 series type CS 2-3-4 from 160A to 800A, power supply 12V DC, display by mechanical indicator.

Two layers change-over switches MSY series types CS 2-3-4-5 from 160A to 1250A, power supply 220V AC, display by mechanical indicator.

Two layers change-over switches MS series type CS 3-4-5-6 from 315A to 3150A and GT series 4000A, multiple power supply voltage 24V DC, 110/220 AC, visualisation by display and mechanical indicator.

Horizontal change-over switches MS series type CO 4-5-6 from 630A to 3150A, multiple power supply 24V DC, 110/220 AC, display by digital display and mechanical indicator.

## **ACCESSORIES**

Bridge connections for two layers change-over switches of CS2, CS3, CS4 e CS5 series.

Special executions and special power supply voltages on request.

Handle for emergency manual operation supplied with the change over switch

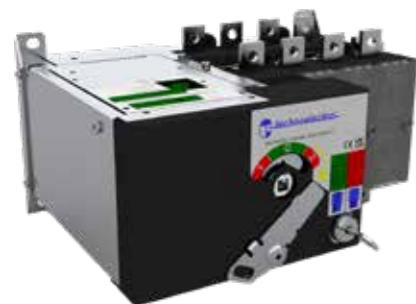

**CS2**



**CS4**



**CS6**

Alimentazione _electrical feeding		12 V DC	24 V DC	110/220 V AC	multiten- sione _multiple power supply	
Tipo _type	Corrente nominale _rated current	POLI _POLES	CODICE _CODES	CODICE _CODES	CODICE _CODES	CODICE _CODES
<b>CS2</b>	160A	3	120018MSX1	120018MSX	120018MSY	-
		4	120118MSX1	120118MSX	120118MSY	-
	200A	3	120028MSX1	120028MSX	120028MSY	-
		4	120128MSX1	120128MSX	120128MSY	-
	250A	3	120038MSX1	120038MSX	120038MSY	-
		4	120138MSX1	120138MSX	120138MSY	-
315A	3	120048MSX1	120048MSX	120028MSY	-	
	4	120148MSX1	120148MSX	120148MSY	-	
<b>CS3</b>	315A	3	-	130018MSX	130018MSY	130018MS
		4	-	130118MSX	130118MSY	130118MS
	400A	3	-	130028MSX	130028MSY	130028MS
		4	-	130128MSX	130128MSY	130128MS
	500A	3	-	130038MSX	130038MSY	130038MS
		4	-	130138MSX	130138MSY	130138MS
<b>CS4</b>	630A	3	-	140038MSX	140038MSY	140038MS
		4	-	140138MSX	140138MSY	140138MS
	800A	3	-	140048MSX	140048MSY	140048MS
		4	-	140148MSX	140148MSY	140148MS
	800A	3	-	150008MSX	150008MSY	150008MS
		4	-	150108MSX	150108MSY	150108MS
<b>CS5</b>	1000A	3	-	150018MSX	150018MSY	150018MS
		4	-	150118MSX	150118MSY	150118MS
	1250A	3	-	150028MSX	150028MSY	150028MS
		4	-	150128MSX	150128MSY	150128MS
	1600A	3	-	-	-	150038MS
		4	-	-	-	150138MS
<b>CS6</b>	1600A	F.N.	-	-	-	15013FN8MS
		3	-	-	-	150048MS
	2000A	4	-	-	-	150148MS
		F.N.	-	-	-	15014FN8MS
	2500A	3	-	-	-	150058MS
		4	-	-	-	150158MS
<b>GT6</b>	2500A	F.N.	-	-	-	15015FN8MS
		3	-	-	-	150068MS
	3150A	4	-	-	-	150168MS
		F.N.	-	-	-	15016FN8MS
	1600A	3	-	-	-	160008MS
		4	-	-	-	160108MS
<b>CO4</b>	1600A	F.N.	-	-	-	16010FN8MS
		3	-	-	-	160018MS
	2000A	4	-	-	-	160118MS
		F.N.	-	-	-	16011FN8MS
	2500A	3	-	-	-	160028MS
		4	-	-	-	160128MS
<b>CO5</b>	2500A	F.N.	-	-	-	16012FN8MS
		3	-	-	-	160038MS
	3150A	4	-	-	-	160138MS
		F.N.	-	-	-	16013FN3MS
	1600A	3	-	-	-	160003MS
		4	-	-	-	160103MS
<b>CO6</b>	1600A	F.N.	-	-	-	16010FN3MS
		3	-	-	-	160013MS
	2000A	4	-	-	-	160113MS
		F.N.	-	-	-	16011FN3MS
	2500A	3	-	-	-	160023MS
		4	-	-	-	160123MS
2500A	F.N.	-	-	-	16012FN3MS	
	3	-	-	-	160033MS	
3150A	4	-	-	-	160033MS	



**CS3**



**CS5**



**GT6**

Alimentazione _electrical feeding			multiten- sione _multiple power supply
Tipo _type	Corrente nominale _rated current	Poli _poles	Codice _code
<b>CO4</b>	630A	3	140033MS
		4	140133MS
	800A	3	140043MS
		4	140143MS
	800A	3	150003MS
		4	150103MS
1000A	3	150013MS	
	4	150113MS	
1250A	3	150023MS	
	4	150123MS	
1600A	3	150033MS	
	4	150133MS	
	F.N.	15013FN3MS	
2000A	3	150043MS	
	4	150143MS	
	F.N.	15014FN3MS	
2500A	3	150053MS	
	4	150153MS	
	F.N.	15015FN3MS	
3150A	3	150063MS	
	4	150163MS	
	F.N.	15016FN3MS	
1600A	3	160003MS	
	4	160103MS	
	F.N.	16010FN3MS	
2000A	3	160013MS	
	4	160113MS	
	F.N.	16011FN3MS	
2500A	3	160023MS	
	4	160123MS	
	F.N.	16012FN3MS	
3150A	3	160033MS	
	4	160033MS	

**SERIE\_SERIES CMO**

Caratteristiche tecniche _Technical Features	Tipo _Type		CS2			
	In	A	160	200	250	315
Corrente nominale _Rated current	In	A	160	200	250	315
Tensione nominale d'isolamento _Rated insulation voltage	Ui	V	1500	1500	1500	1500
Corrente nominale termica _Thermal current	Ith	A	160	200	250	315
Corrente nominale d' impiego _Rated operational current						
AC-21A/B	400V	A	160	200	250	250/315
	500V	A	160	200	250	250/315
	690V	A	160	200	250	250/315
AC-22A/B	400V	A	160	200	250	250/315
	500V	A	160	200	250	250/250
	690V	A	160	200	250	250/250
AC-23A/B	400V	A	160	200	250	250/250
	500V	A	125	160	200	200/200
	690V	A	100	125	160	160/160
DC-21A/B*	220V	A	160	200	250	250/315
	420V	A	160	200	250	250/315
	560V	A	-	-	-	-
DC-22A/B*	220V	A	160	200	250	250/315
	420V	A	160	200	250	250/250
	560V	A	-	-	-	-
*DC-23A/B	220V	A	160	200	250	250/250
	420V	A	160	200	250	250/250
	560V	A	-	-	-	-
Potere di chiusura _Rated making capacity	400V AC23	A	1600	2000	2500	2500
Potere di interruzione _Breaking capacity	400V AC23	A	1280	1600	2000	2000
Corrente di breve durata _Short-circuit withstand current	1 sec	kA	8	8	8	8
Corrente di breve durata _Short-circuit withstand current	0,25 sec	kA	16	16	16	16
Potere di chiusura in corto circuito _Short-circuit making capacity	400V	kA	13,5	13,5	13,5	13,5
Potenza nominale d'impiego _Rated operational power	400V AC23	kW	85	105	130	130
Corrente di corto circuito condizionata da fusibile _Rated fuse short-circuit current						
Tipo fusibile _Backup fuse		A	160	200	250	315
Valore efficace _R.M.S. value		kA	50	50	50	50
Valore di picco _Peak value		kA	16	20	25	27
Durata meccanica _Mechanical endurance		n.	10000	10000	10000	10000
Durata elettrica _Electrical endurance		n.	2000	2000	2000	2000/200
Potenza dissipata per polo _Power losses for pole		W	1,6	2,4	3,8	6,1
Dimensione cavo _Cable section		mmq	70	95	120	185
Dimensione barre _Bars dimension		MM	20x4	20x5	20x6	22x8
Tempi di commutazione _ Change over time	[IH o IH]	sec	1,8	1,8	1,8	1,8
Tensione di alimentazione c.c. _DC voltage supply	± 10%		12/24	12/24	12/24	12/24
	min		18	18	18	18
Tensione di alimentazione c.a. _AC voltage supply	± 10%		-	-	-	-
Consumo comando elettrico _Power motor consumption	A		3	3	3	3
Peso netto _Net weight	3P	Kg	5,5	5,5	5,5	5,5
	4P		6	6	6	6

Caratteristiche tecniche _Technical Features	Tipo _Type		CS3			CS4/CO4	
	In	A	315	400	500	630	800
Corrente nominale _Rated current	In	A	315	400	500	630	800
Tensione nominale d'isolamento _Rated insulation voltage	Ui	V	1500	1500	1500	1500	1500
Corrente nominale termica _Thermal current	Ith	A	315	400	500	630	800
Corrente nominale d' impiego _Rated operational current							
AC-21A/B	400V	A	315	400	500/500	630	630/800
	500V	A	315	400	400/500	630	630/800
	690V	A	315	400	400/500	630	630/800
AC-22A/B	400V	A	315	400	400/500	630	630/800
	500V	A	315	400	500/500	630	630/630
	690V	A	315	400	400/400	630	630/630
AC-23A/B	400V	A	315	400	500/500	630	630/630
	500V	A	250	315	315/315	500	500/500
	690V	A	200	250	250/250	400	400/400
DC-21A/B*	220V	A	315	400	400/500	630	630/800
	420V	A	315	400	400/500	630	630/800
	560V	A	315	400	400/500	630	630/800
DC-22A/B*	220V	A	315	400	400/500	630	630/800
	420V	A	315	400	400/400	630	630/630
	560V	A	315	400	400/400	630	630/630
*DC-23A/B	220V	A	315	400	400/400	630	630/800
	420V	A	315	400	400/400	630	630/800
	560V	A	315	400	400/400	630	630/800
Potere di chiusura _Rated making capacity	400V AC23	A	3150	4000	5000	6300	6300
Potere di interruzione _Breaking capacity	400V AC23	A	2520	3200	4000	5040	5040
Corrente di breve durata _Short-circuit withstand current	1 sec	kA	13	13	13	26,6	26,6
Corrente di breve durata _Short-circuit withstand current	0,25 sec	kA	26	26	26	53	53
Potere di chiusura in corto circuito _Short-circuit making capacity	400V	kA	26	26	26	30	30
Potenza nominale d'impiego _Rated operational power	400V AC23	kW	165	210	210	330	330
Corrente di corto circuito condizionata da fusibile _Rated fuse short-circuit current							
Tipo fusibile _Backup fuse		A	315	400	500	630	800
Valore efficace _R.M.S. value		kA	50	50	50	50	50
Valore di picco _Peak value		kA	27	30	37	40	50
Durata meccanica _Mechanical endurance		n.	8000	8000	8000	8000	8000
Durata elettrica _Electrical endurance		n.	1500	1500	1500/200	1500	1500/200
Potenza dissipata per polo _Power losses for pole		W	5,9	9,4	14,8	15,6	25,7
Dimensione cavo _Cable section		mmq	185	2x120	2x150	2x185	2x240
Dimensione barre _Bars dimension		MM	30x6	2x25x5	2x30x5	2x40x5	2x40x6
Tempi di commutazione _ Change over time	[HI o IH]	sec	1,8	1,8	1,8	2,8	2,8
Tensione di alimentazione c.c. _DC voltage supply	± 10%		24	24	24	24	24
	min		18	18	18	18	18
Tensione di alimentazione c.a. _AC voltage supply	± 10%		230	230	230	230	230
Consumo comando elettrico _Power motor consumption	A		4	4	4	4	4
Peso netto _Net weight	3P	Kg	17	17	17	22	22
	4P		18	18	18	24	24

**SERIE\_SERIES CMO**

Caratteristiche tecniche _Technical Features	Tipo _Type		CS5/CO5						
	In	A	800	1000	1250	1600	2000	2500	3150
Corrente nominale _Rated current	In	A	800	1000	1250	1600	2000	2500	3150
Tensione nominale d'isolamento _Rated insulation voltage	Ui	V	1500	1500	1500	1500	1500	1500	1500
Corrente nominale termica _Thermal current	Ith	A	800	1000	1250	1600	2000	2500	3150
Corrente nominale d' impiego _Rated operational current									
AC-21A/B	400V	A	800	1000	1250	1600	2000	2500	3150
	500V	A	800	1000	1250	1250	1600	2000	2500
	690V	A	800	1000	1250	1250	1250	1250	1250
AC-22A/B	400V	A	800	1000	1250	1250	1250	-	-
	500V	A	800	1000	1250	-	-	-	-
	690V	A	800	1000	1250	-	-	-	-
AC-23A/B	400V	A	800	1000	1250	-	-	-	-
	500V	A	630	800	1000	-	-	-	-
	690V	A	500	630	800	-	-	-	-
DC-21A/B*	220V	A	800	1000	1250	1600	-	-	-
	420V	A	-	-	-	-	-	-	-
	560V	A	-	-	-	-	-	-	-
DC-22A/B*	220V	A	800	1000	1250	-	-	-	-
	420V	A	-	-	-	-	-	-	-
	560V	A	-	-	-	-	-	-	-
*DC-23A/B	220V	A	800	630	800	-	-	-	-
	420V	A	-	-	-	-	-	-	-
	560V	A	-	-	-	-	-	-	-
Potere di chiusura _Rated making capacity	400V AC23	A	8000	10000	12500	-	-	-	-
Potere di interruzione _Breaking capacity	400V AC23	A	6400	8000	10000	-	-	-	-
Corrente di breve durata _Short-circuit withstand current	1 sec	kA	50	50	50	50	50	50	50
Corrente di breve durata _Short-circuit withstand current	0,25 sec	kA	100	100	100	100	100	100	100
Potere di chiusura in corto circuito _Short-circuit making capacity	400V	kA	105	105	105	105	105	105	105
Potenza nominale d'impiego _Rated operational power	400V AC23	kW	420	525	630	630	630	-	-
Corrente di corto circuito condizionata da fusibile _Rated fuse short-circuit current									
Tipo fusibile _Backup fuse		A	800	1000	1250	-	-	-	-
Valore efficace _R.M.S. value		kA	100	100	100	-	-	-	-
Valore di picco _Peak value		kA	50	60	70	-	-	-	-
Durata meccanica _Mechanical endurance		n.	4000	4000	4000	4000	4000	2500	2500
Durata elettrica _Electrical endurance		n.	1000	1000	1000	500	500	500	500
Potenza dissipata per polo _Power losses for pole		W	15,6	24,3	38	38,3	61,3	91,3	145,5
Dimensione cavo _Cable section		mmq	2x240	-	-	-	-	-	-
Dimensione barre _Bars dimension		MM	2x50x5	2x50x8	3x50x8	3x50x12	4x50x12	6x50x12	2x80x10
Tempi di commutazione _ Change over time	[HI o IH]	sec	3	3	3	3,8	3,8	3,8	3,8
Tensione di alimentazione c.c. _DC voltage supply	± 10%		24	24	24	24	24	24	24
	min		18	18	18	18	18	18	18
Tensione di alimentazione c.a. _AC voltage supply	± 10%		230	230	230	230	230	230	230
Consumo comando elettrico _Power motor consumption	A		5÷6	5÷6	5÷6	5÷6	5÷6	5÷6	5÷6
Peso netto _Net weight	3P	Kg	37	37	37	51	51	70	70
	4P		37	37	37	53	53	74	74

Caratteristiche tecniche _Technical Features	Tipo _Type		CS6/CO6				GT
	In	A	1600	2000	2500	3150	4000
Corrente nominale _Rated current	In	A	1600	2000	2500	3150	4000
Tensione nominale d'isolamento _Rated insulation voltage	Ui	V	1500	1500	1500	1500	1500
Corrente nominale termica _Thermal current	Ith	A	1600	2000	2500	3150	4000
Corrente nominale d' impiego _Rated operational current							
AC-21A/B	400V	A	1600	2000	2500	3150	4000
	500V	A	1600	2000	2500	3150	4000
	690V	A	1250	1250	1250	1250	-
AC-22A/B	400V	A	1600	2000	2500	1600	-
	500V	A	1250	1250	1250	-	-
	690V	A	400	400	800	-	-
AC-23A/B	400V	A	1250	1250	-	-	-
	500V	A	800	800	-	-	-
	690V	A	400	400	-	-	-
DC-21A/B*	220V	A	1600	2000	-	-	-
	420V	A	-	-	-	-	-
	560V	A	-	-	-	-	-
DC-22A/B*	220V	A	-	-	-	-	-
	420V	A	-	-	-	-	-
	560V	A	-	-	-	-	-
*DC-23A/B	220V	A	-	-	-	-	-
	420V	A	-	-	-	-	-
	560V	A	-	-	-	-	-
Potere di chiusura _Rated making capacity	400V AC23	A	12500	12500	-	-	-
Potere di interruzione _Breaking capacity	400V AC23	A	10000	10000	-	-	-
Corrente di breve durata _Short-circuit withstand current	1 sec	kA	60	60	70	70	50
Corrente di breve durata _Short-circuit withstand current	0,25 sec	kA	120	120	140	140	-
Potere di chiusura in corto circuito _Short-circuit making capacity	400V	kA	105	105	105	105	100
Potenza nominale d'impiego _Rated operational power	400V AC23	kW	630	630	-	-	-
Corrente di corto circuito condizionata da fusibile _Rated fuse short-circuit current							
Tipo fusibile _Backup fuse		A	-	-	-	-	-
Valore efficace _R.M.S. value		kA	-	-	-	-	-
Valore di picco _Peak value		kA	-	-	-	-	-
Durata meccanica _Mechanical endurance		n.	4000	2500	2500	2500	2500
Durata elettrica _Electrical endurance		n.	1000	500	500	500	500
Potenza dissipata per polo _Power losses for pole		W	47,8	74,7	85,4	118,1	272
Dimensione cavo _Cable section		mmq	-	-	-	-	-
Dimensione barre _Bars dimension		MM	2x80x10	2x80x10	3x80x10	3x100x10	-
Tempi di commutazione _ Change over time	[HI o IH]	sec	3,8	3,8	3,8	3,8	22
Tensione di alimentazione c.c. _DC voltage supply	± 10%		24	24	24	24	24
	min		18	18	18	18	18
Tensione di alimentazione c.a. _AC voltage supply	± 10%		230	230	230	230	230
Consumo comando elettrico _Power motor consumption	A		5÷6	5÷6	5÷6	5÷6	3,8
Peso netto _Net weight	3P	Kg	51	53	74	108	196
	4P		53	55	80	116	230



**CS2**

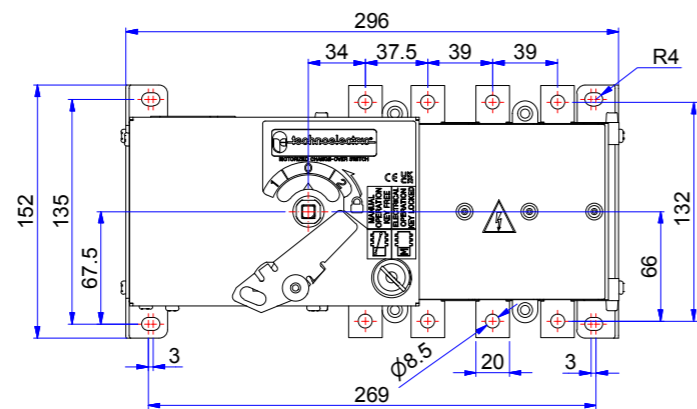

**CS4**

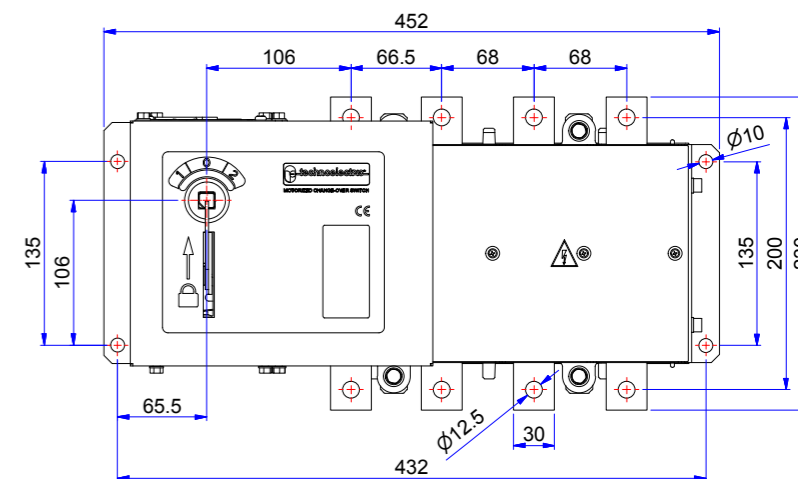

**CS3**

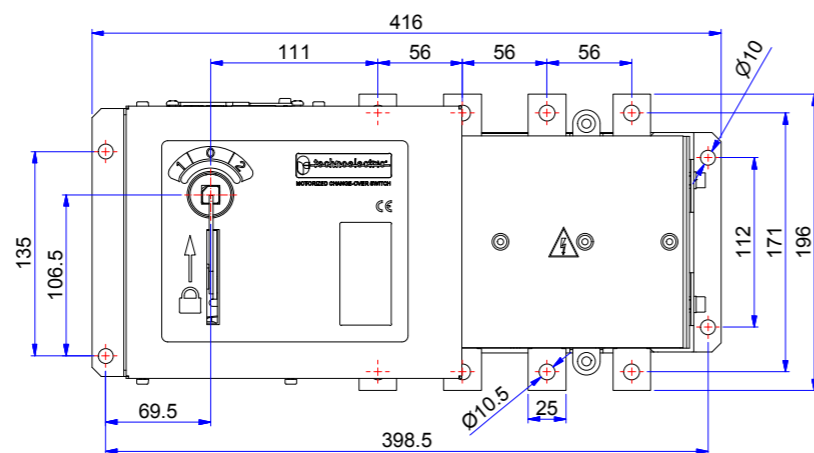

**CS5 800 ÷ 1250 A**

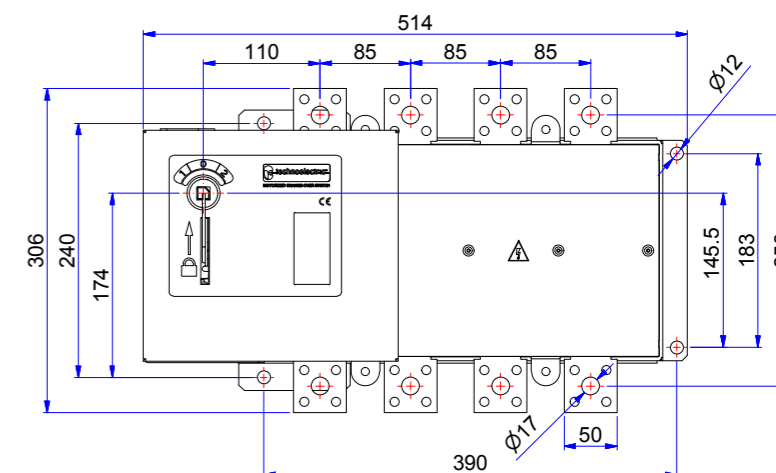

**CS5 1600 ÷ 2000 A**

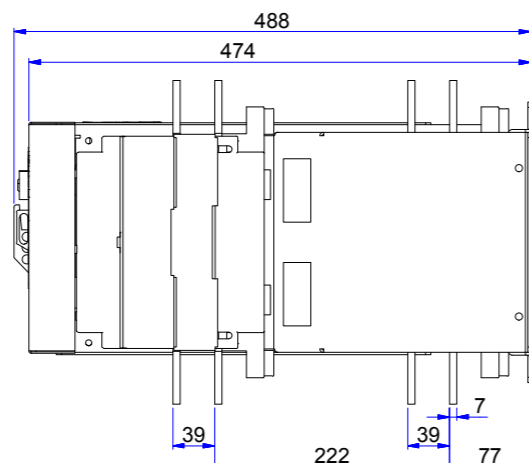
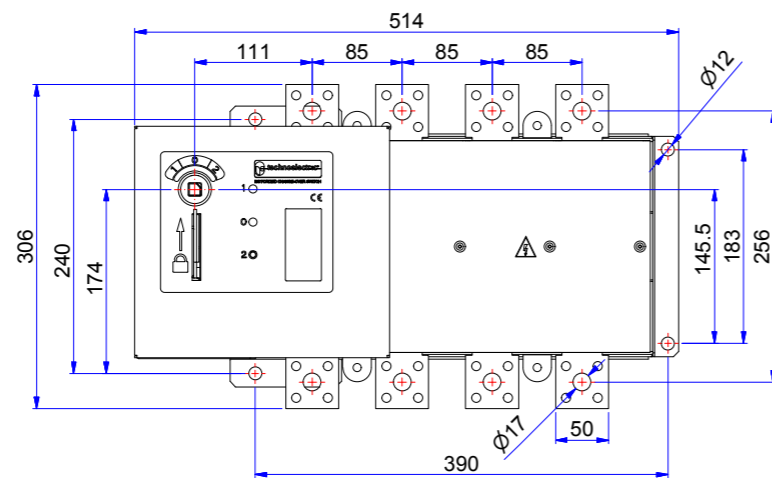

**CS6 FN 1600 A**

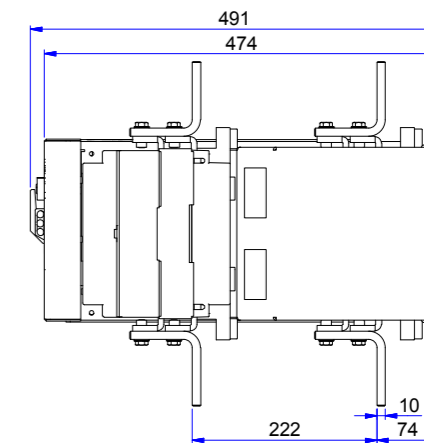
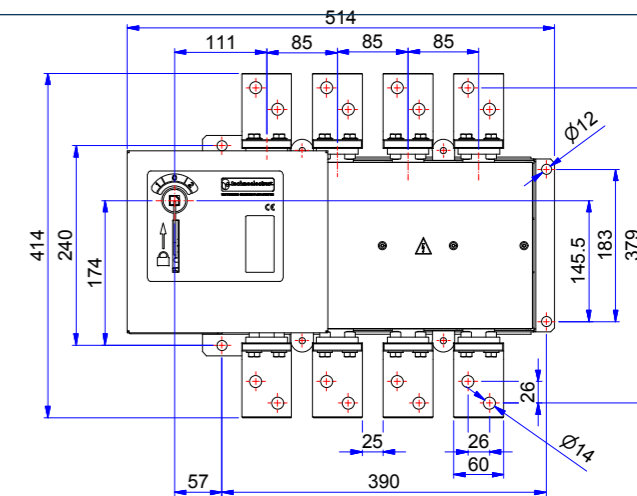

**CS5 2500 ÷ 3150 A**

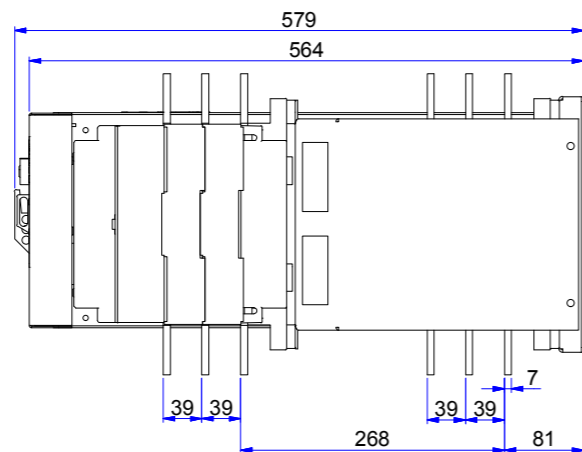
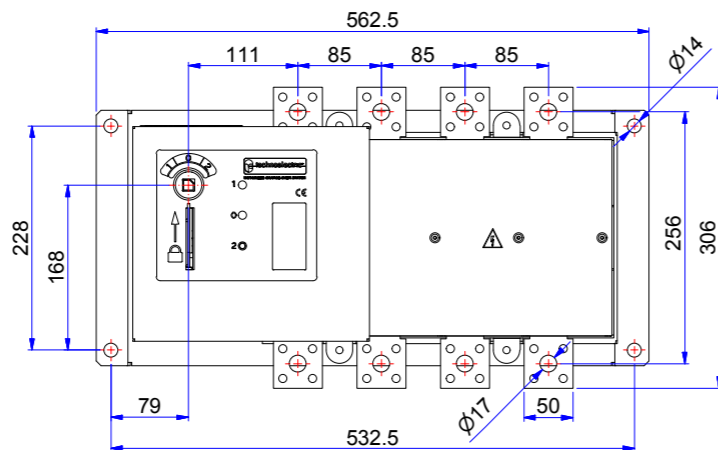

**CS6 1600 A | N 1250 A**

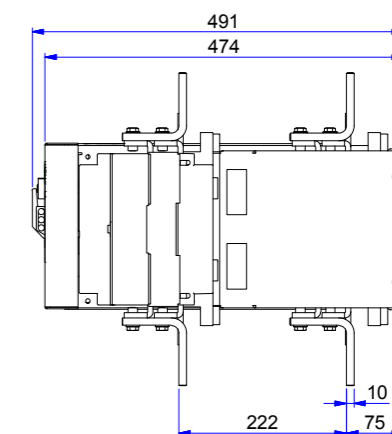
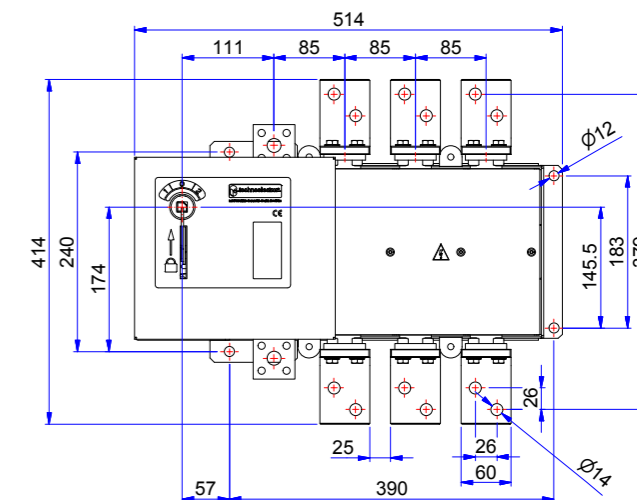

**CS6MS FN 2000 A**

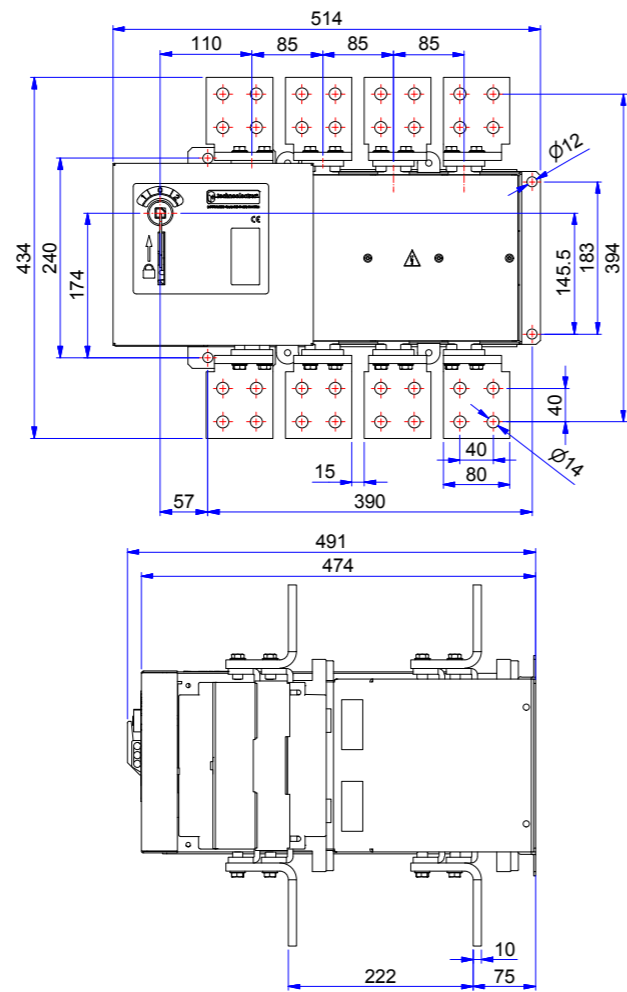

**CS6 2500 A**

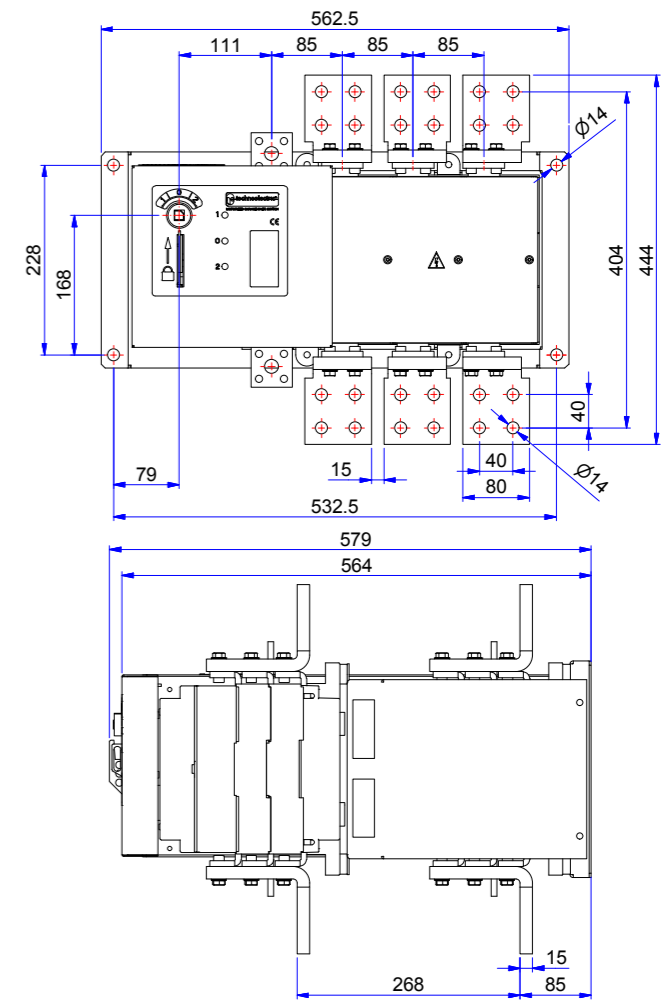

**CS6 2000 A | N1250 A**

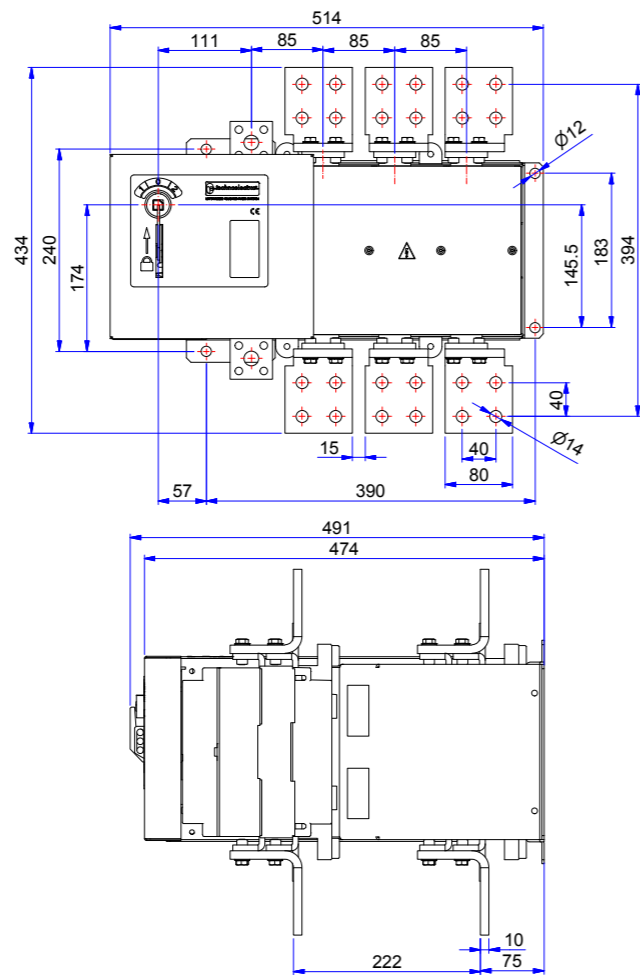

**CS6 FN 2500 A**

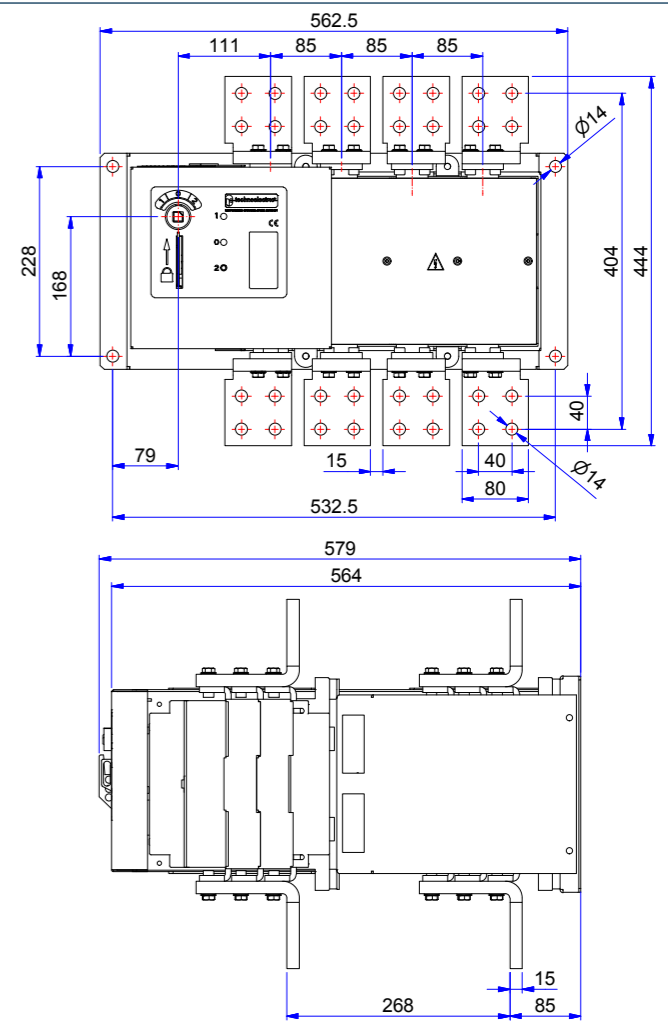

**CS6 3150 A**

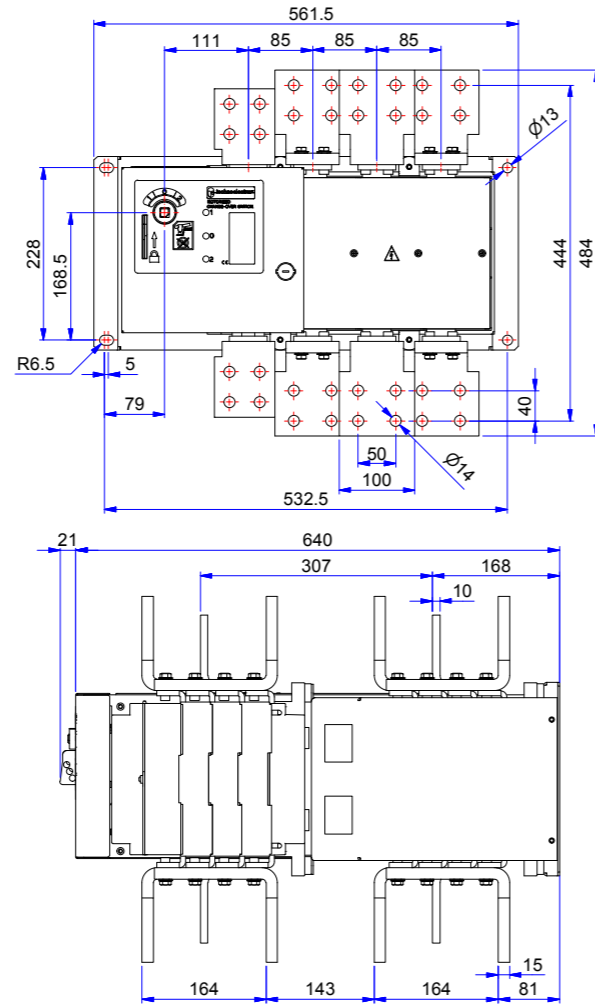

**GT 4000 A 4P**

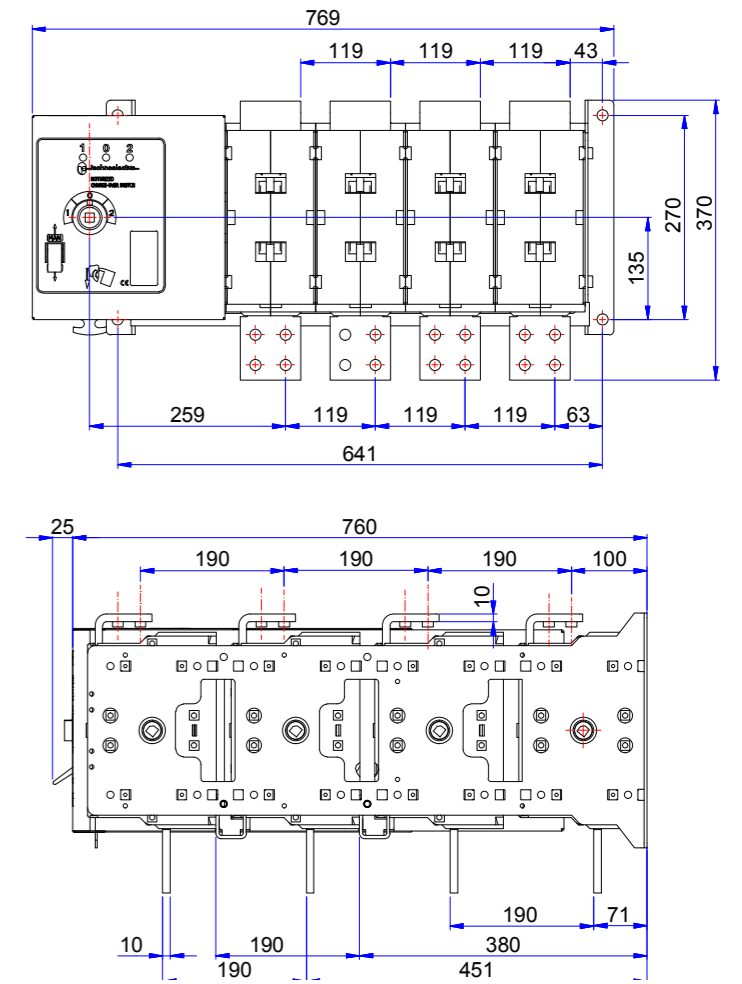

**GT 4000 A 3P**

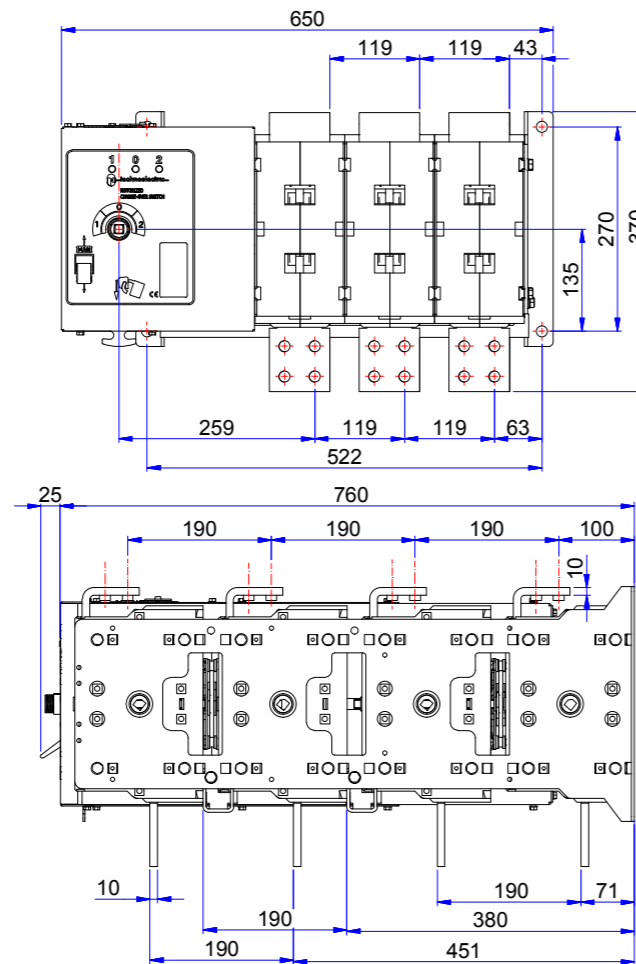

**CO4**

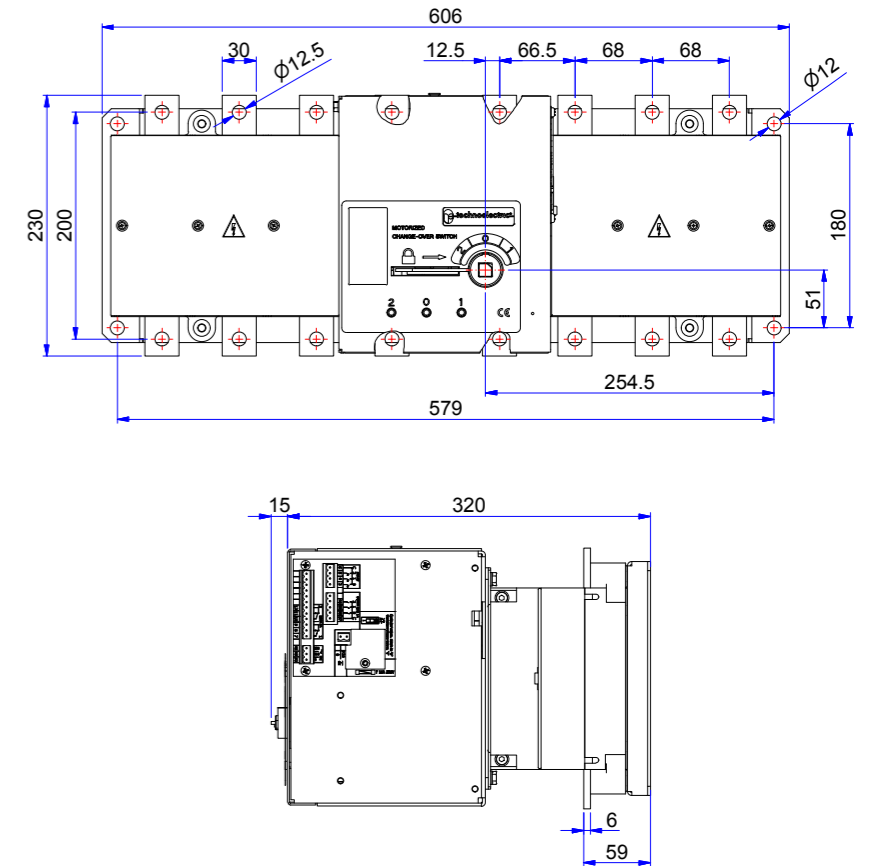



**CO5 800 ÷ 3150 A**

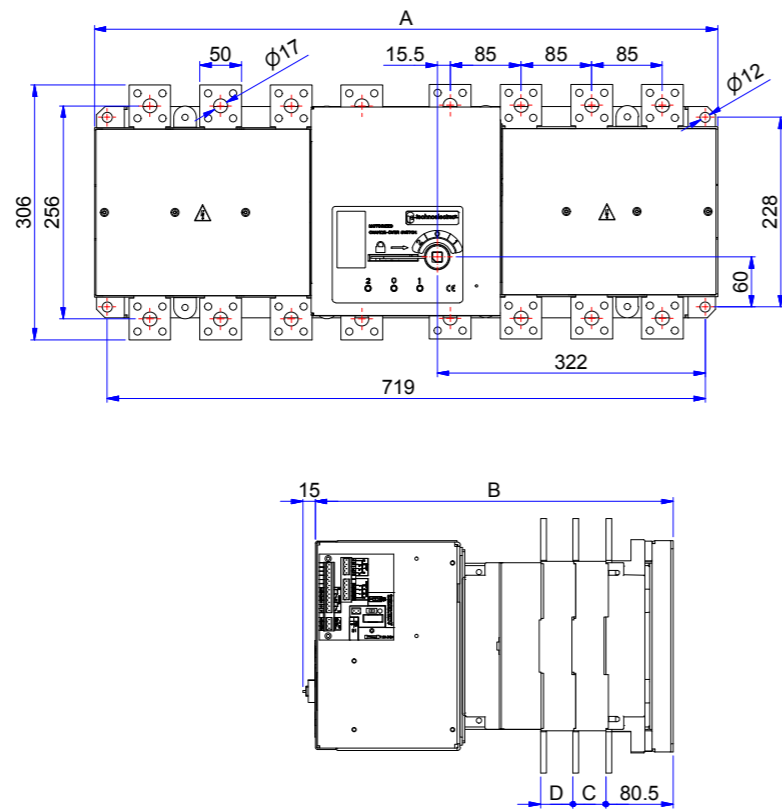

**CO6 2000 A**

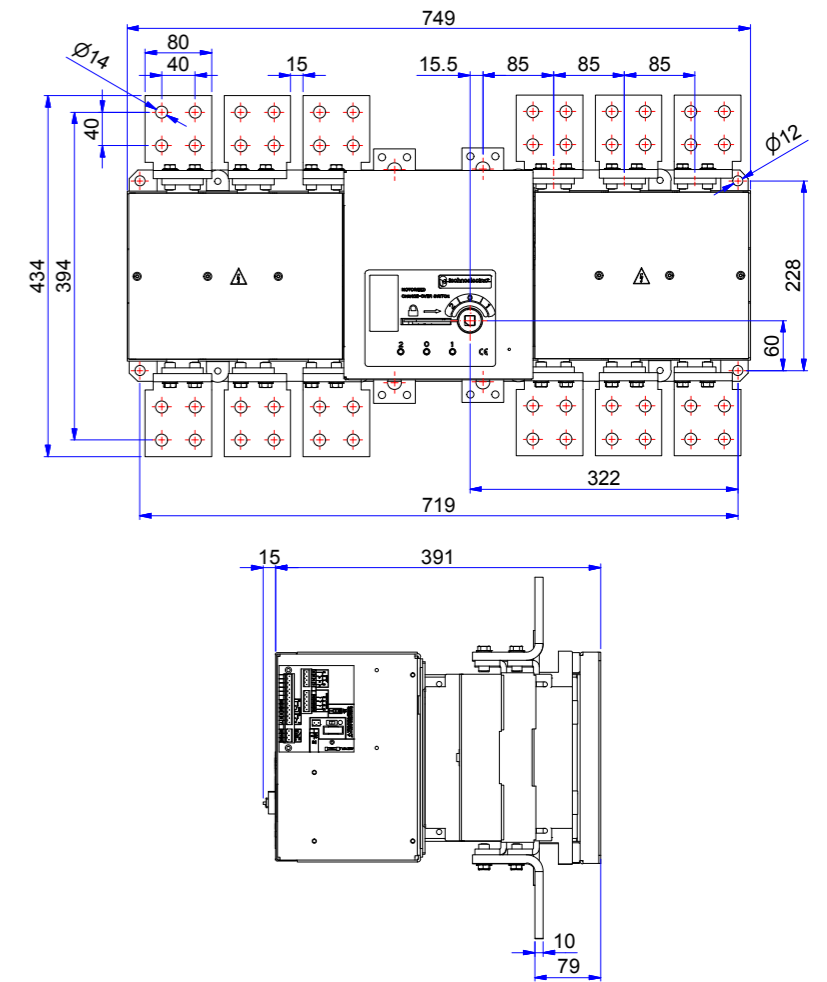

**CO6 1600 A**

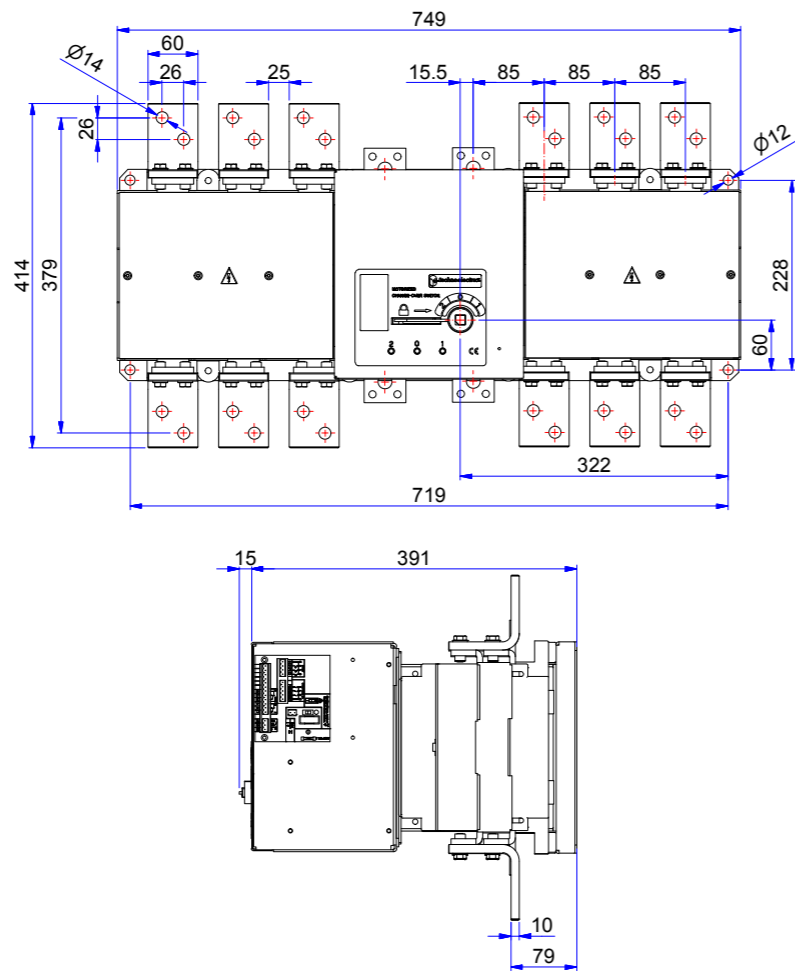

**CO6 2500 A**

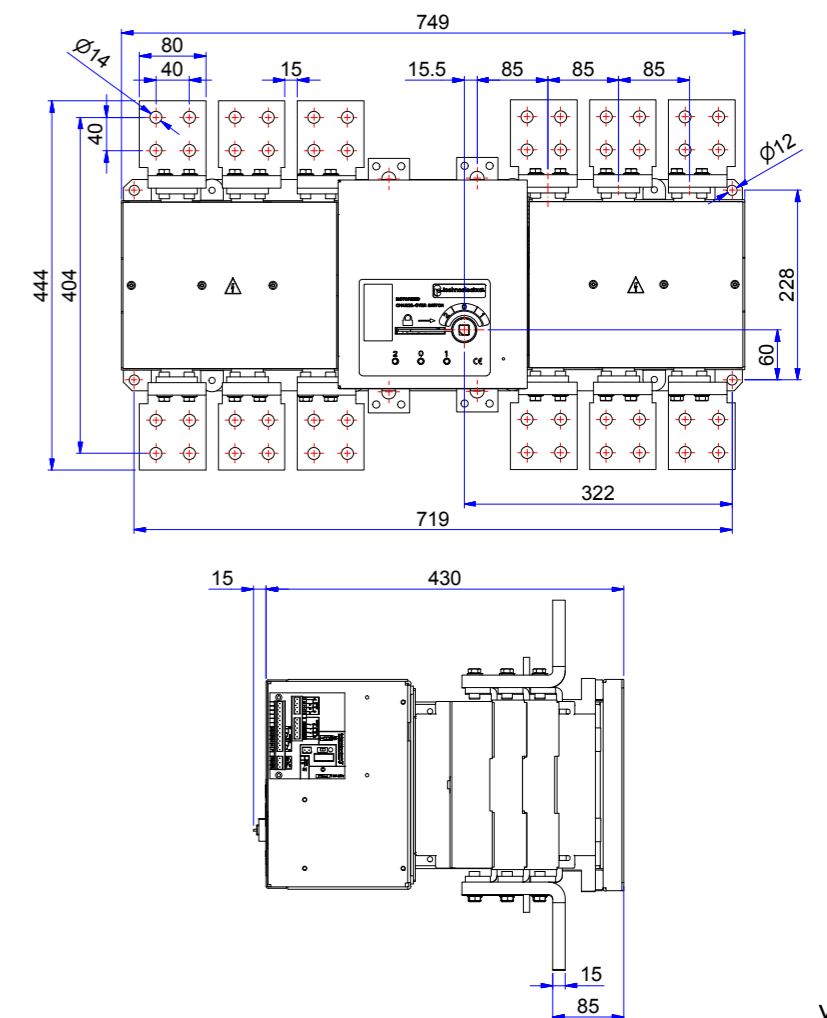

CO6 3150 A

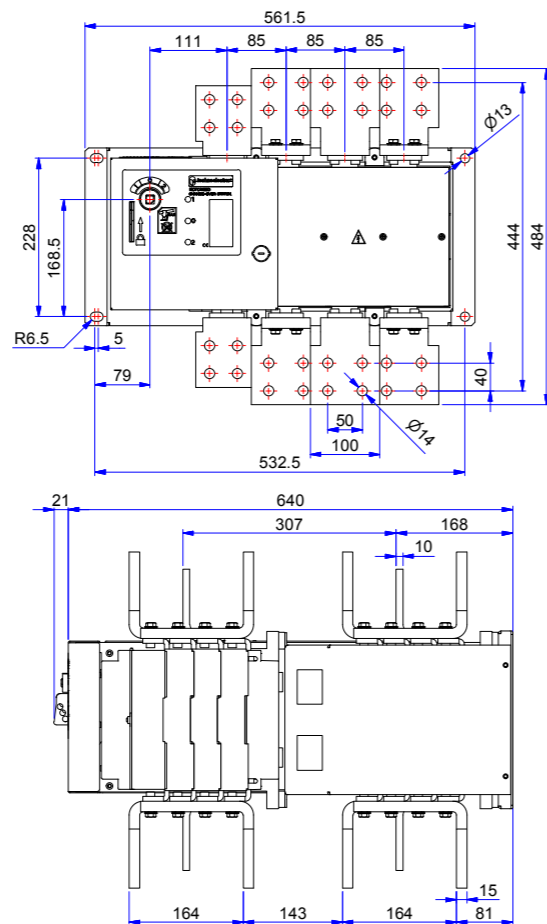

**SCHEMA MORSETTIERA 24V DC - 110 ÷ 220V AC PER CSMS | COMS | GT MS**  
 \_terminal board diagram 24V dc - 100 ÷ 220V AC rating type CSMS | COMS | GT MS

**SCHEMA MORSETTIERA 24V DC | 220V AC PER CS MS X-Y**  
 \_terminal board diagram 24V dc | 220V ac rating type CS MS X-Y

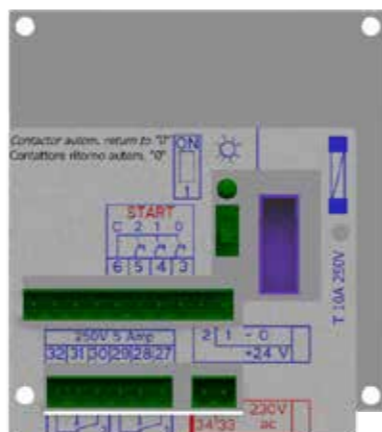
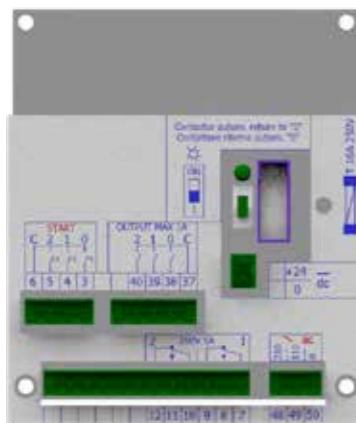

**CONNESSIONI A PONTE**  
 \_Connecting bridges

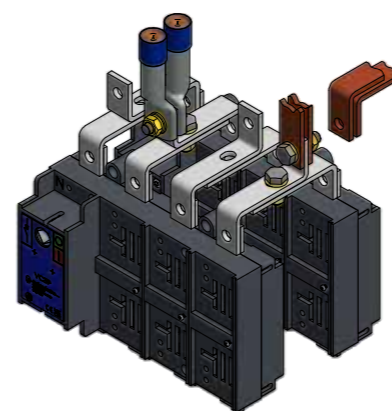

**CODICE CAVO\SBARRA \_Code cable\bar**

Tipo _type	CS2 160-315A		CS3 315-500A		CS4 630-800A	
Poli _poles	3P	4P	3P	4P	3P	4P
Codice _code	18408	18409	18419	18412	18417	18418

**CODICE SBARRA \_Code bar**

Tipo _type	CS4 630-800A		CS5 800-1250A	
Poli _poles	3P	4P	3P	4P
Codice _code	18427	18428	18424	18414

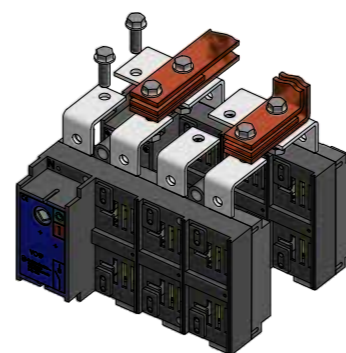

**CODICE SBARRA \_Code bar**

Tipo _type	CS5 1600-2000A		CS5 1600-2000A	
Poli _poles	3P	4P	4P FN	
Codice _code	18438	18439	18440	

**N° 1 PIATTO PER TERMINALI SEZIONATORI**  
 \_n° 1 terminal plate for switches



**CODICE CAVO \_Code cable**

Tipo _type	CO - CS 5	
Piatto _plate	4 MM	6 MM
Codice _code	18138	
	18139	



Visualizzazione delle posizioni "1", "0", "2", a indice meccanico, blocco a lucchetto (max. 3 lucchetti). Con il blocco lucchetto inserito sono interdetto le manovre manuali e elettriche.  
Commutatore tipo CS2 MSX MSX1 MSY

\_Display of position "1", "0", "2" by mechanical indicator, padlock (max. 3), with the padlock on both manual and electrical operations are prevented.  
Change-over type CS2 MSX MSX1 MSY



Visualizzazione delle posizioni "1", "0", "2" a mezzo display e indice meccanico, con il blocco lucchetto inserito sono interdetto le manovre manuali e elettriche.  
Commutatore tipo CO MS - CS MS.

\_Display of position "1", "0", "2" by means of digital display and mechanical indicator, with the padlock on both manual and electrical operations are prevented.  
Change-over type CO MS - CS MS.

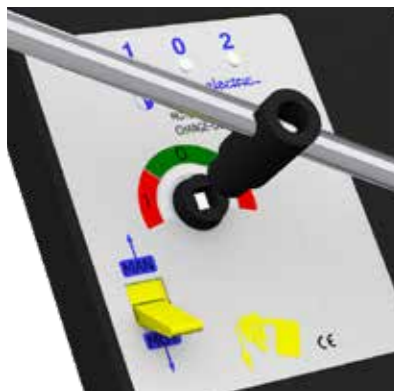

Visualizzazione delle posizioni "1", "0", "2" a mezzo display e indice meccanico, con il blocco lucchetto inserito sono interdetto le manovre manuali e elettriche.  
Commutatore tipo GT MS.

\_Display of position "1", "0", "2" by means of digital display and mechanical indicator, with the padlock on both manual and electrical operations are prevented.  
Change-over type GT MS.



Blocco elettrico a chiave per la selezione della manovra manuale o elettrica.

\_Electrical key lock for selection of manual or electrical operation.



Vano fusibile; sulla scheda di alimentazione è posto il microinterruttore per la scelta della logica di funzionamento:

1. funzionamento ad impulso (min. 150ms)  
ON. funzionamento CONTACTORE, (contatto mantenuto) ritorno automatico in "0", led acceso.

\_Fuse block; on the supply board there is the micro switch to select the logic of the operation:  
1. operation by impulse (min. 150ms)  
ON. operation type CONTACTOR (maintained contact), automatic return to "0", led switch-on.

## RICAMBI \_replacement

### 18049

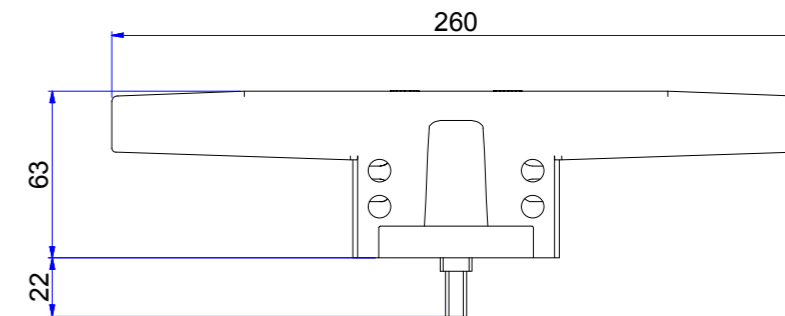

Maniglia per la manovra manuale di emergenza. Commutatore tipo CS MSX/Y, taglia 2 codice 18048, taglie 3 e 4 codice 18049

\_Handle for emergency manual operation. Change-over switch type MSX/Y size 2 code 18048, size 3 and 4 code 18049

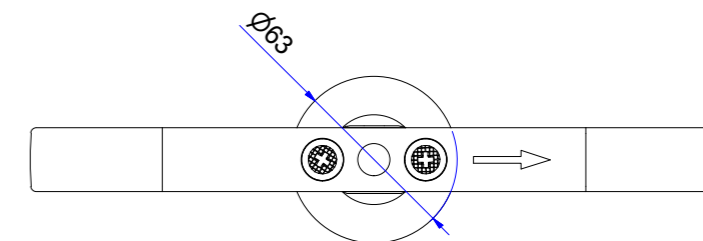

Maniglia per il comando manuale d'emergenza in dotazione standard  
\_Handle is supplied with the change over switch

### 18072

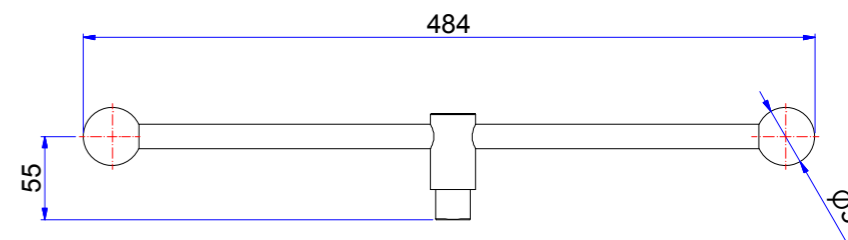

Maniglia per la manovra manuale di emergenza con impugnatura scorrevole. Commutatore tipo CS - CO - GT, taglie 5 e 6 codice 18072

\_Handle for emergency manual operation with sliding grip suitable. Change-over switch type CS - CO - GT size 5 and 6 code 18072

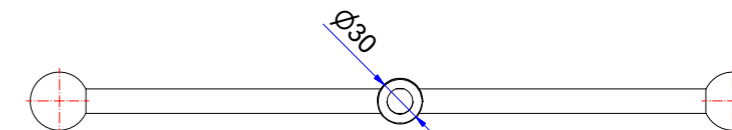

Maniglia per il comando manuale d'emergenza in dotazione standard  
\_Handle is supplied with the change over switch



# CENTRALINA TMC

## \_CHANGEOVER CONTROL UNIT TMC



Realizzata per allestire quadri di commutazione rete/ gruppo elettrogeno. Svolge la funzione di controllo e comando di un gruppo elettrogeno ed inserisce l'utenza alla rete o al generatore.

### COMPLETA DI DISPLAY RETROILLUMINATO PER VISUALIZZARE:

- Tre voltmetri rete.
- Tre voltmetri generatore.
- Tre amperometri rete/generatore.
- Frequenzimetro rete/generatore.
- Potenze kVA (apparenti) rete/generatore.
- Voltmetro batteria.

Con la semplice pressione del tasto freccia, vengono visualizzati tutti gli strumenti elettrici della rete, del generatore. In caso di anomalia, il display indica il messaggio dell'anomalia intervenuta.

### FUNZIONI:

- Sorveglianza automatica delle anomalie con messaggi sul display.
- Controllo completo voltmetrico trifase della rete e del gruppo elettrogeno (sottotensione, sovratensione, asimmetria fasi, errata sequenza fasi, sottofrequenza e sovralfrequenza).
- Pulsanti manuali di avviamento e arresto del gruppo elettrogeno.
- Pulsante per deviare la rete o il generatore sull'utenza.
- Spie presenza rete e generatore.
- Spie di commutazione avvenuta.
- Testi in 6 lingue: Italiano, Inglese, Francese, Tedesco, Spagnolo, Portoghese.
- Porta seriale RS485.
- Protocollo MOD Bus RTU.
- Comandi remoti (avviamento, blocco, EJP).
- Orologio per programmare l'avviamento e il blocco del gruppo elettrogeno

Made to set up grid/generator switching panels. It performs the control and command function of a generator and connects the user to the network or generator.

### COMPLETE WITH BACKLIT DISPLAY TO VIEW:

- Three mains voltmeters
- Three generator voltmeters.
- Three mains / generator ammeters.
- Mains / generator frequency meter.
- Power kVA (apparent) mains / generator.
- Battery voltmeter.

By simply pressing the arrow key, all the electrical instruments of the network and of the generator are displayed. In the event of an anomaly, the display indicates the message of the anomaly occurred.

### FUNCTIONS:

- Automatic monitoring of anomalies with display messages.
- Complete three-phase voltmetric control of mains and genset (undervoltage, overvoltage, phase asymmetry, incorrect phase sequence, underfrequency and overfrequency).
- Genset start-up and stop buttons.
- Button to deviate power user to the mains or generator.
- Mains and generator indicators.
- Switching indicators.
- Texts in 6 languages: Italian, English, French, German, Spanish and Portuguese.
- RS485 serial port.
- MOD Bus RTU Protocol.
- Remote controls (start, stop, EJP).
- Clock for programming genset starting or stopping.

## Dati tecnici

### \_Technical Data

Adatta per batterie _Suitable for batteries	12Vdc	24Vdc
Campo di funzionamento _Operating range	8 ÷ 48Vdc	
Assorbimento _Absorption	130mA a 12Vdc	70mA a 24Vdc
Buco di tensione sull'alimentazione da batteri _Voltage dip on battery power supply	Da 10Vdc a 0Vdc per 250ms	
Tensione di tenuta dielettrica _Dielectric strength voltage between battery voltage circuits and mains/generator voltage circuits	3750Vac 50Hz 1sec	
Campo di misura _Measurement range	80 ÷ 570Vac trifase _three-phase	45 ÷ 340Vac monofase _single-phase
Accuratezza _Accuracy	±1%	
Campo di misura _Measurement range	20mA ÷ 6Aac	
Rapporto trasformatore amperometrico _Amperometric transformer ratio	/5	
Massima corrente visualizzabile _Measurement range	4800Aac	
Accuratezza _Accuracy	±1%	
Temperatura di funzionamento _Operating temperature	-20 ÷ 60°C	
Temperatura di stoccaggio _Storage temperature	-20 ÷ 60°C	
Umidità relativa _Relative humidity	≤ 80%	
Dimensioni (LxHxP) _Dimensions (LxHxW)	157x109x74 mm	
Peso _Weight	450 g	
Grado protezione _Protection class	Frontale _Front IP64	Posteriore _Back IP20

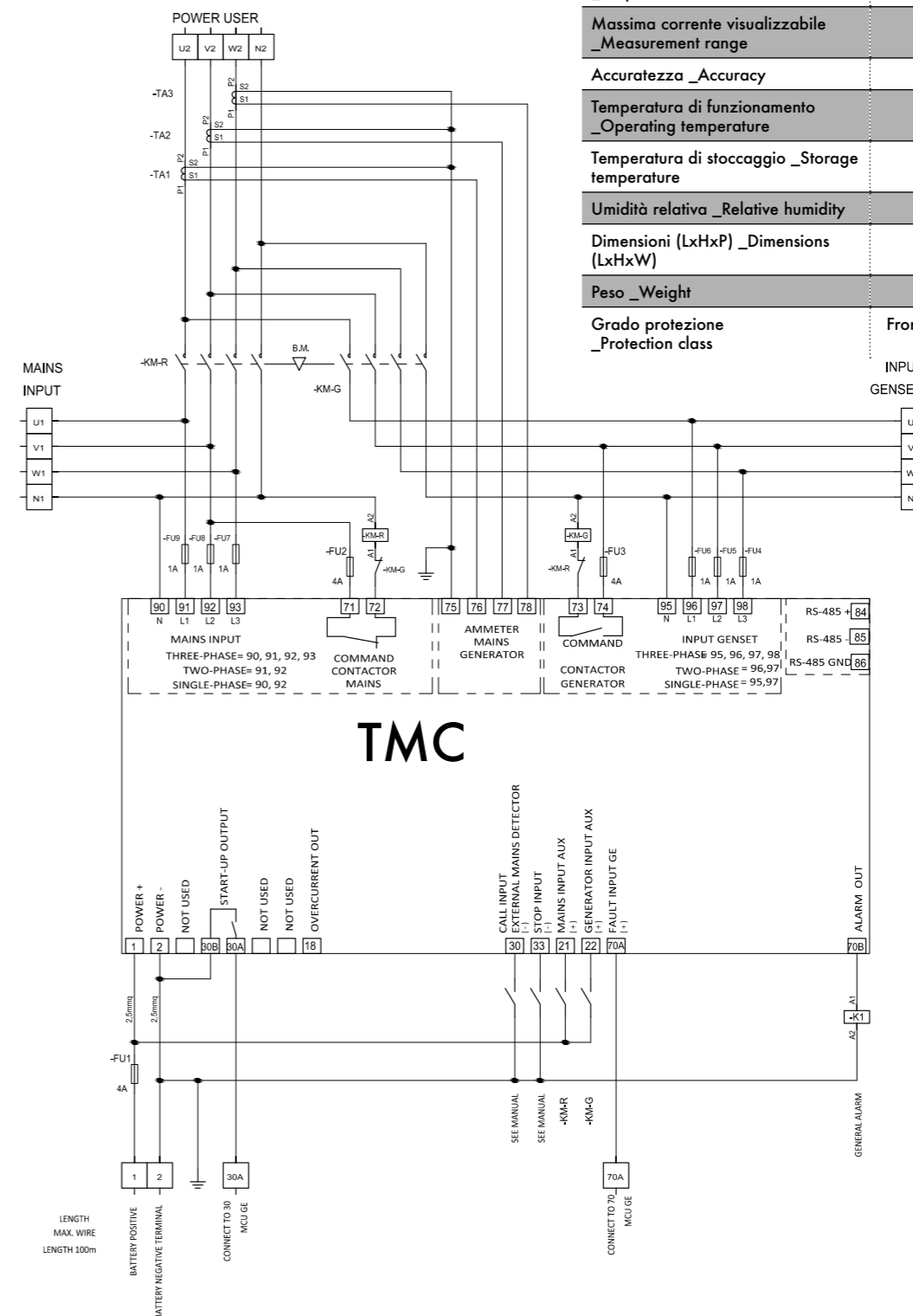



**Technoelectric s.r.l.**

**Via E. Mattei 2/4,  
26823 Castiglione d'Adda LO**

**[www.technoelectric.it](http://www.technoelectric.it)**

**Tel: + 39 0377 42581**

**E-mail: [info@technoelectric.it](mailto:info@technoelectric.it)**